

**United States Patent** [19]

**Matthews**

[11] **Patent Number: Des. 310,017**

[45] **Date of Patent: \*\* Aug. 21, 1990**

[54] **TIE DOWN DEVICE FOR TRUCK BEDS**

[75] **Inventor: James R. Matthews, Hawthorne, Calif.**

[73] **Assignees: James E. Irvin; Amy B. Irvin, both of West Lafayette, Ind.**

[\*\*] **Term: 14 Years**

[21] **Appl. No.: 59,475**

[22] **Filed: Jun. 8, 1987**

[52] **U.S. Cl. .... D8/356**

[58] **Field of Search .... D8/356, 382, 396; 105/369; 248/361, 499; 24/241 PS; 410/105, 104, 101; 280/179 R**

[56] **References Cited**

**U.S. PATENT DOCUMENTS**

- D. 226,167 1/1973 Del Ponte ..... D8/356 X
- D. 241,709 10/1976 Bouche ..... D8/356
- D. 279,314 6/1985 Ishida et al. .... D8/396 X

- D. 297,878 9/1988 Bingstrom ..... D8/382
- 3,213,508 10/1965 Vigerhed ..... D8/356 X
- 4,496,271 1/1985 Spinosa et al. .... 410/105
- 4,850,769 7/1989 Matthews ..... 410/105

*Primary Examiner*—Horace B. Fay, Jr.  
*Attorney, Agent, or Firm*—Woodard, Emhardt, Naughton, Moriarty & McNett

[57] **CLAIM**

The ornamental design for tie down device for truck beds, as shown.

**DESCRIPTION**

FIG. 1 is a side elevational view of a tie-down device for truck beds, the side opposite being a mirror image thereof;

FIG. 2 is an end elevational view thereof;

FIG. 3 is an end elevational view taken opposite from the end shown in FIG. 2; and

FIGS. 4 and 5 are respectively top and bottom plan views thereof.

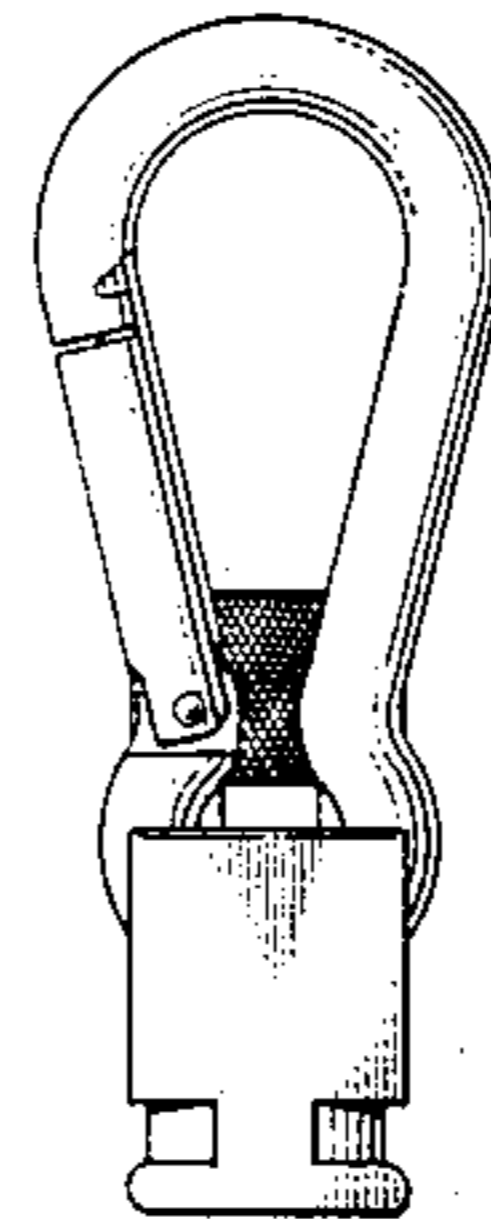

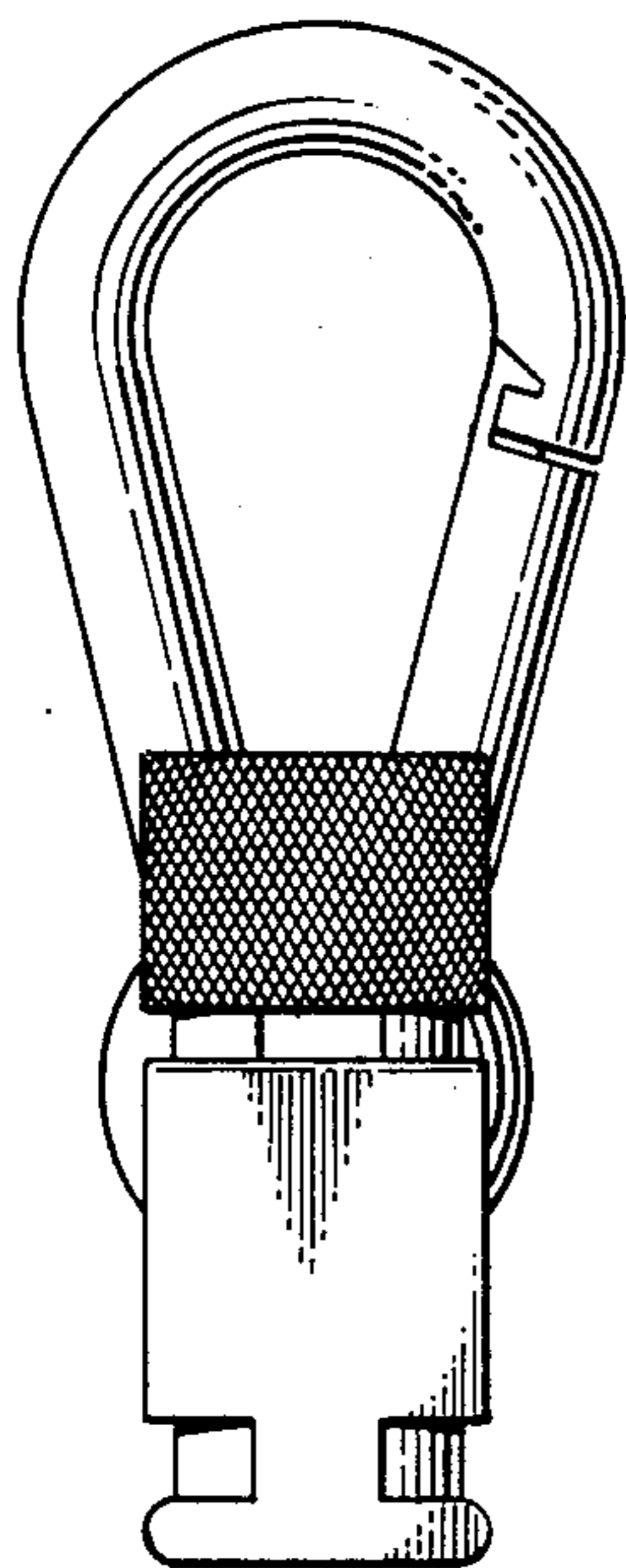

FIG. 2.

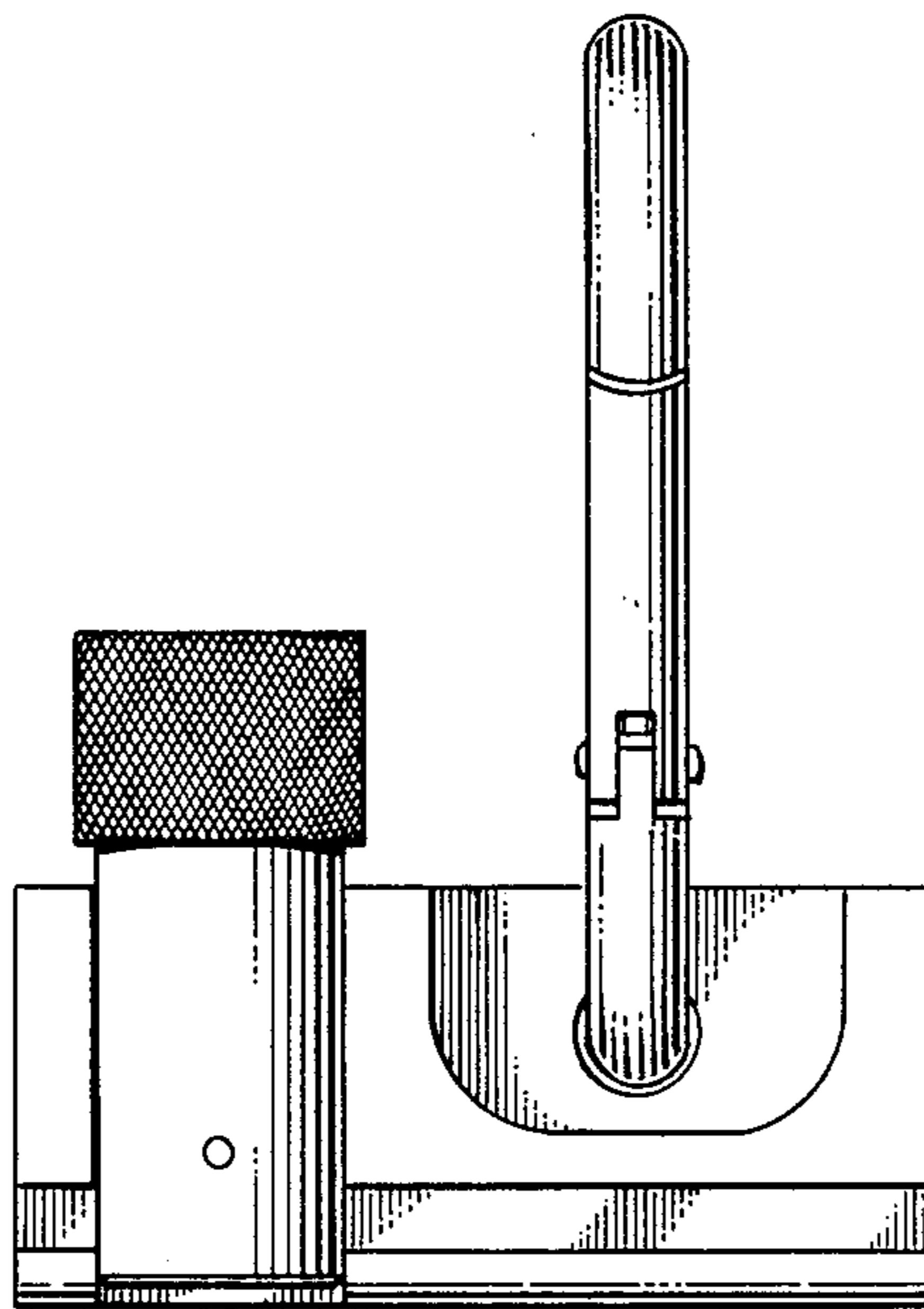

FIG. 1.

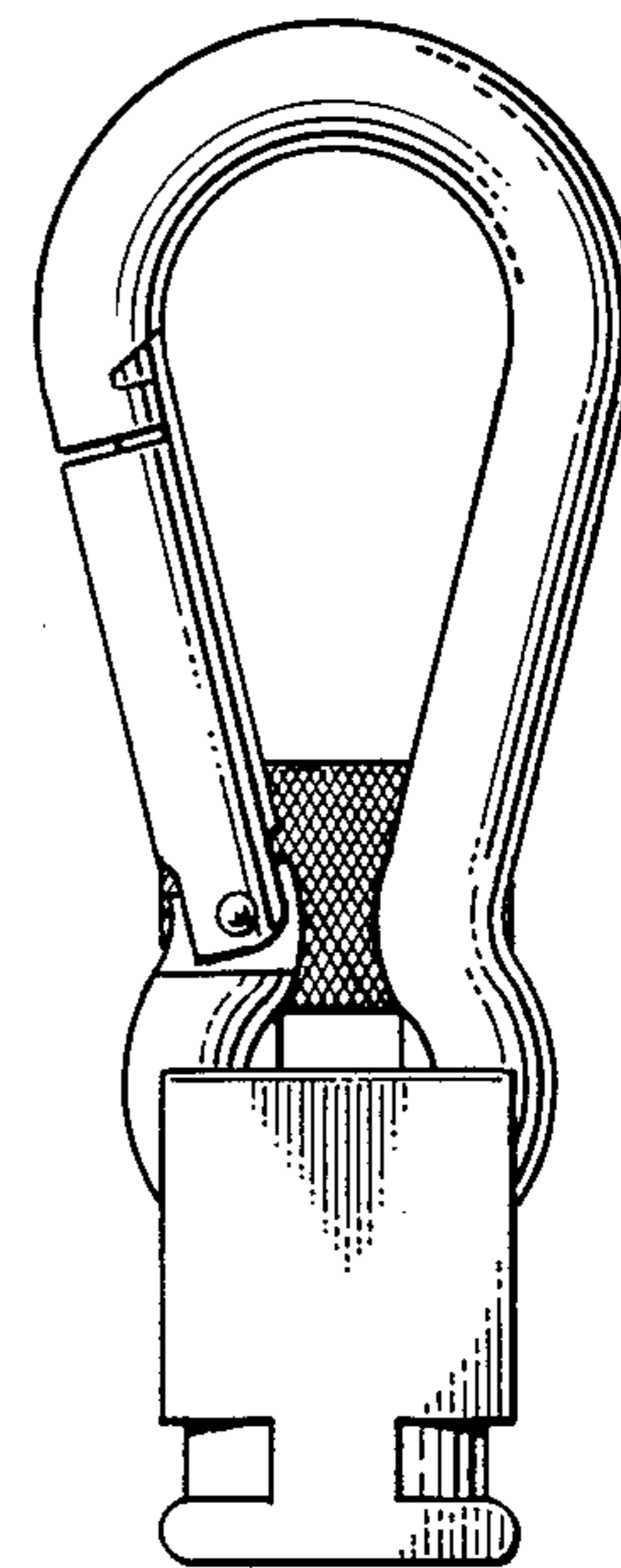

FIG. 3.

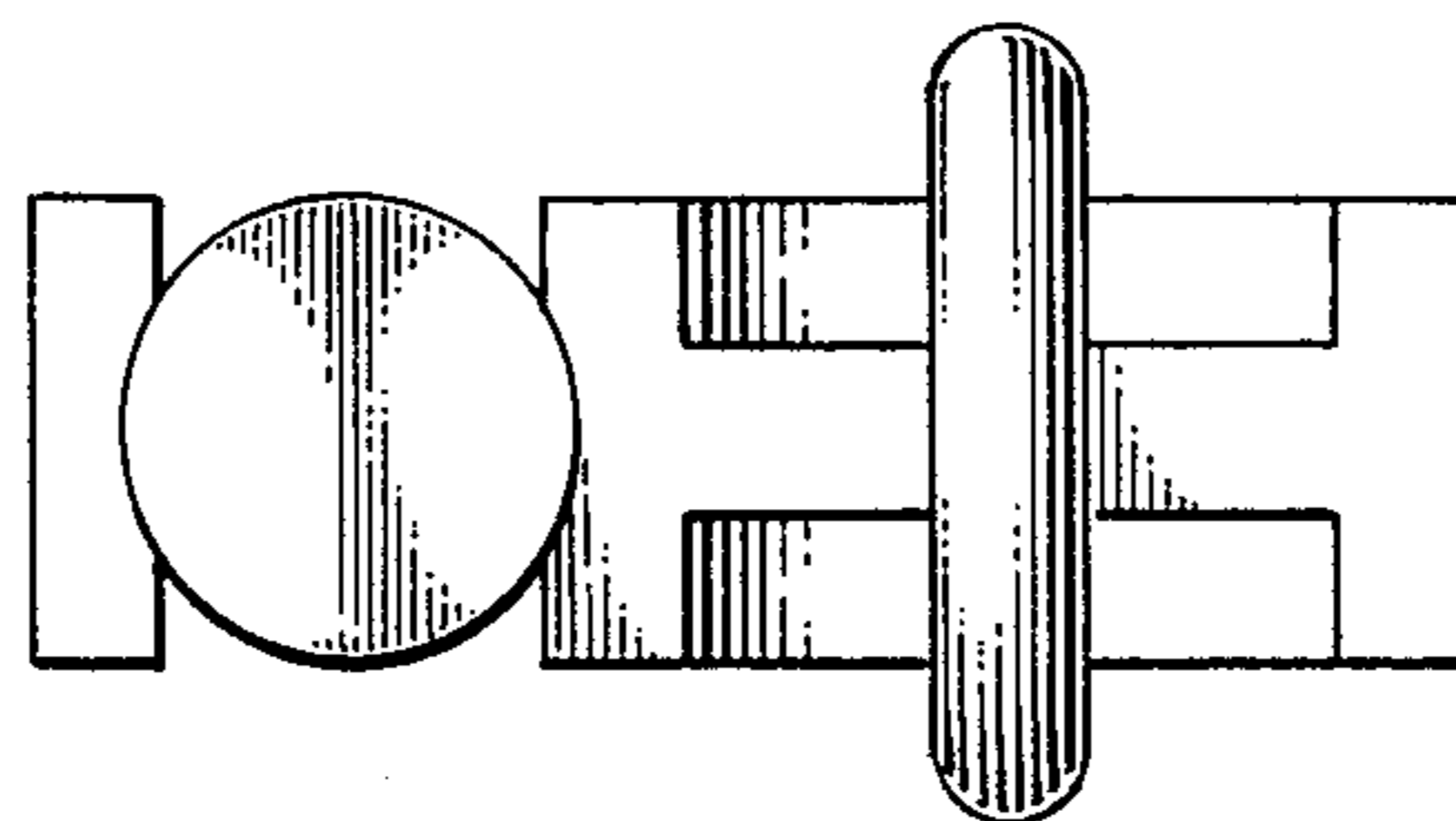

FIG. 4.

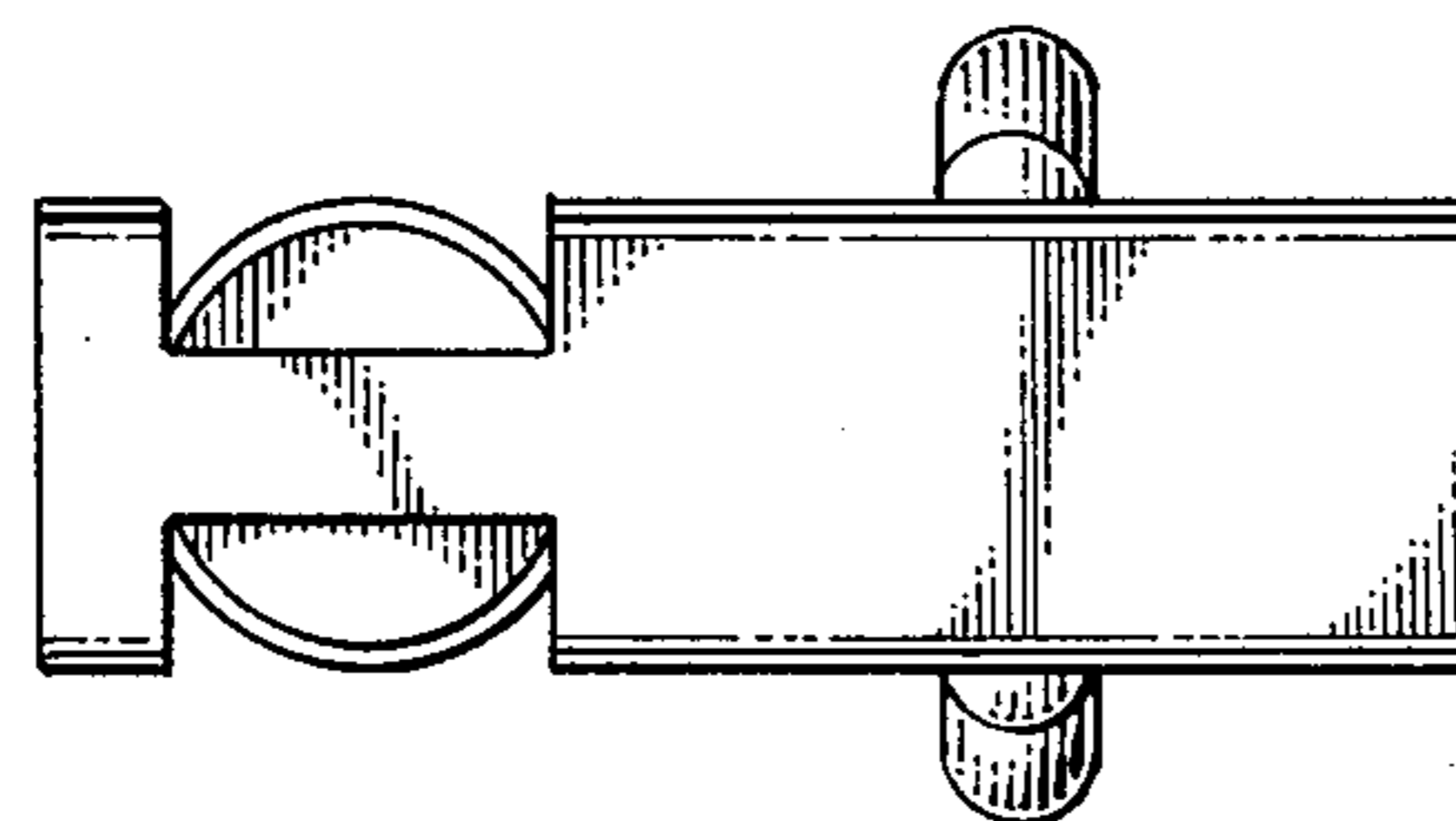

FIG. 5.