

[54] SMALL RIGID PORTABLE COMPARTMENTED CASE

[76] Inventor: Maria Boitani, Via Bissolati, No. 54, Rome 00187, Italy

[\*\*] Term: 14 Years

[21] Appl. No.: 41,738

[22] Filed: Apr. 21, 1987

[30] Foreign Application Priority Data

Oct. 31, 1986 [IT] Italy ..... 36221/86[U]

[52] U.S. Cl. .... D3/74; D3/30.1

[58] Field of Search ..... D3/74, 39; 190/16, 111, 190/117, 110; 206/566

[56] References Cited

U.S. PATENT DOCUMENTS

D. 258,470	3/1981	Chun	.....	D3/39
258,814	5/1882	Scott	.....	190/16
D. 261,825	11/1981	Benson et al.	.....	D3/39
D. 284,526	7/1986	Freeman	.....	D3/74
394,321	12/1881	Wright	.....	190/110 X
818,248	4/1906	Herrnecker	.....	190/111 X
1,311,586	7/1919	Beecher	.....	190/16

2,236,368	3/1941	Haaker	.....	190/16
2,585,745	2/1952	Crosby	.....	190/111
3,335,775	8/1967	Adams	.....	150/117
4,717,024	1/1988	Djezovic	.....	206/566

Primary Examiner—A. Hugo Word  
Assistant Examiner—Doris V. Coles  
Attorney, Agent, or Firm—Wenderoth, Lind & Ponack

[57] CLAIM

The ornamental design for a small rigid portable compartmented case, as shown and described.

DESCRIPTION

FIG. 1 is a front perspective view of a small rigid portable compartmented case, in the closed position, showing my new design;  
FIG. 2 is a rear perspective view thereof;  
FIG. 3 is a left side elevational view with the compartment open, the right side being a mirror image thereof;  
FIG. 4 is a front elevational view with the top and front compartments open;  
FIG. 5 is a rear elevational view thereof;  
FIG. 6 is a perspective view with all of the compartments open;  
FIG. 7 is a top plan view in the closed position; and  
FIG. 8 is a bottom plan view thereof.

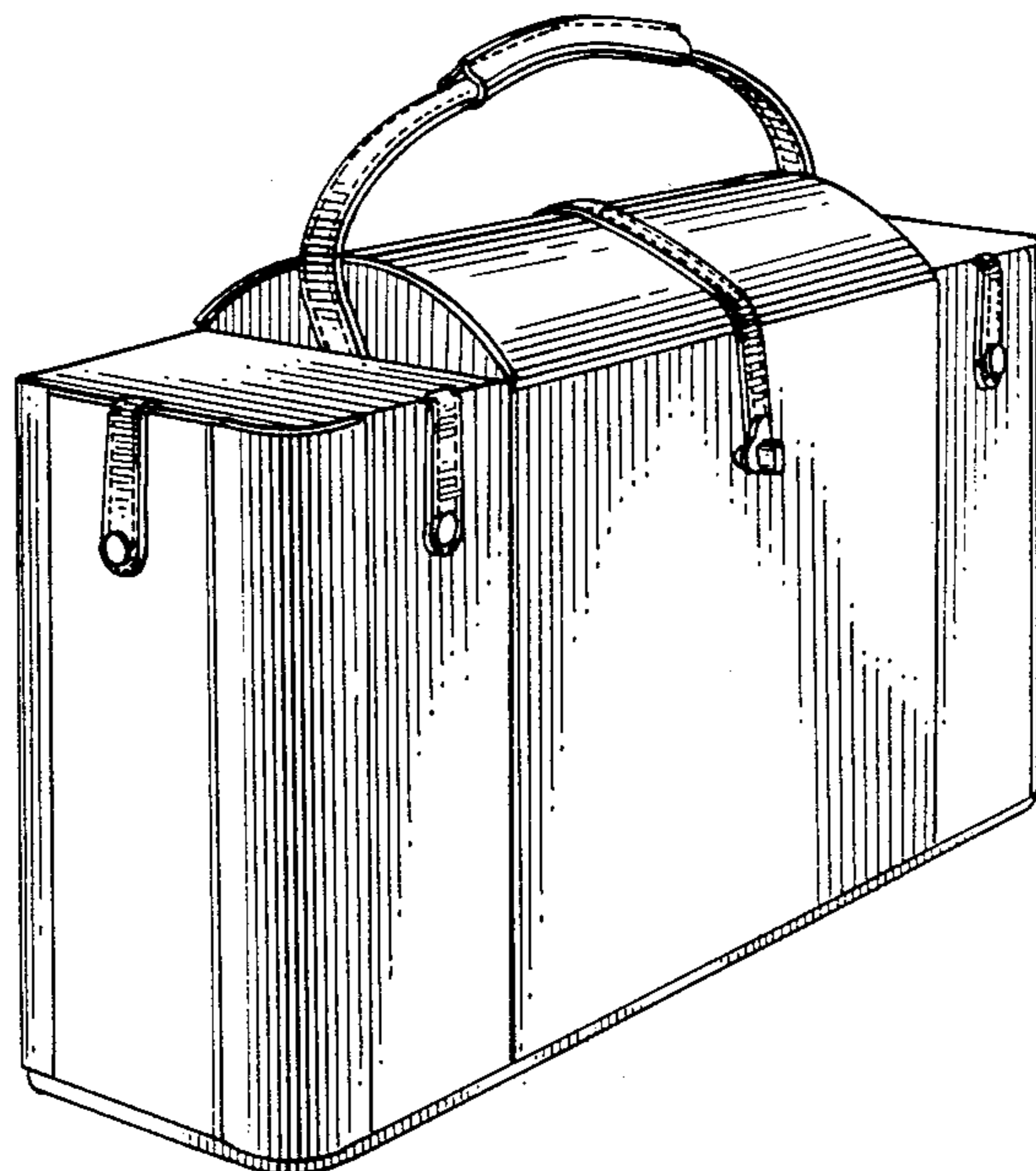

**FIG. 1.**

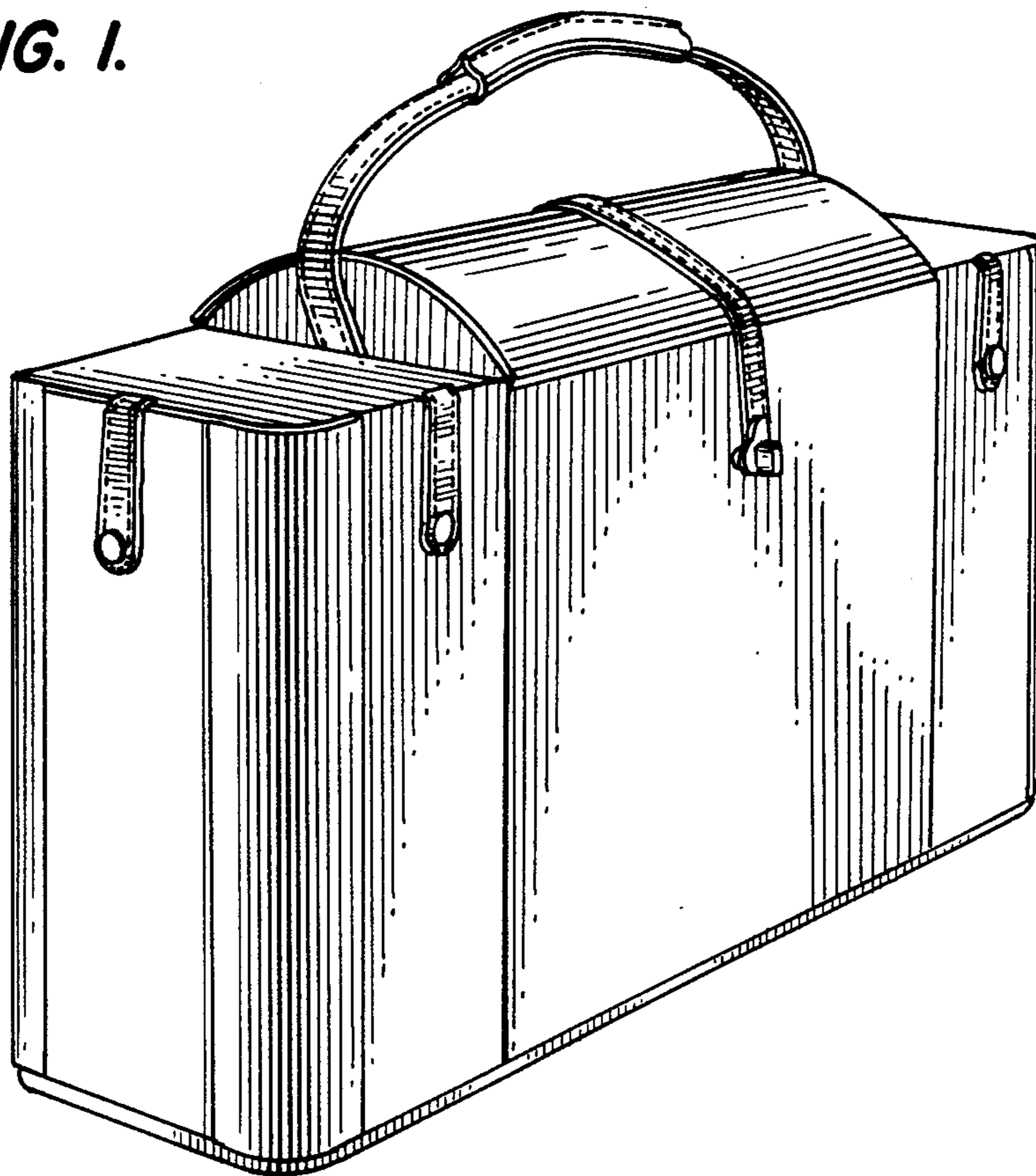

**FIG. 2.**

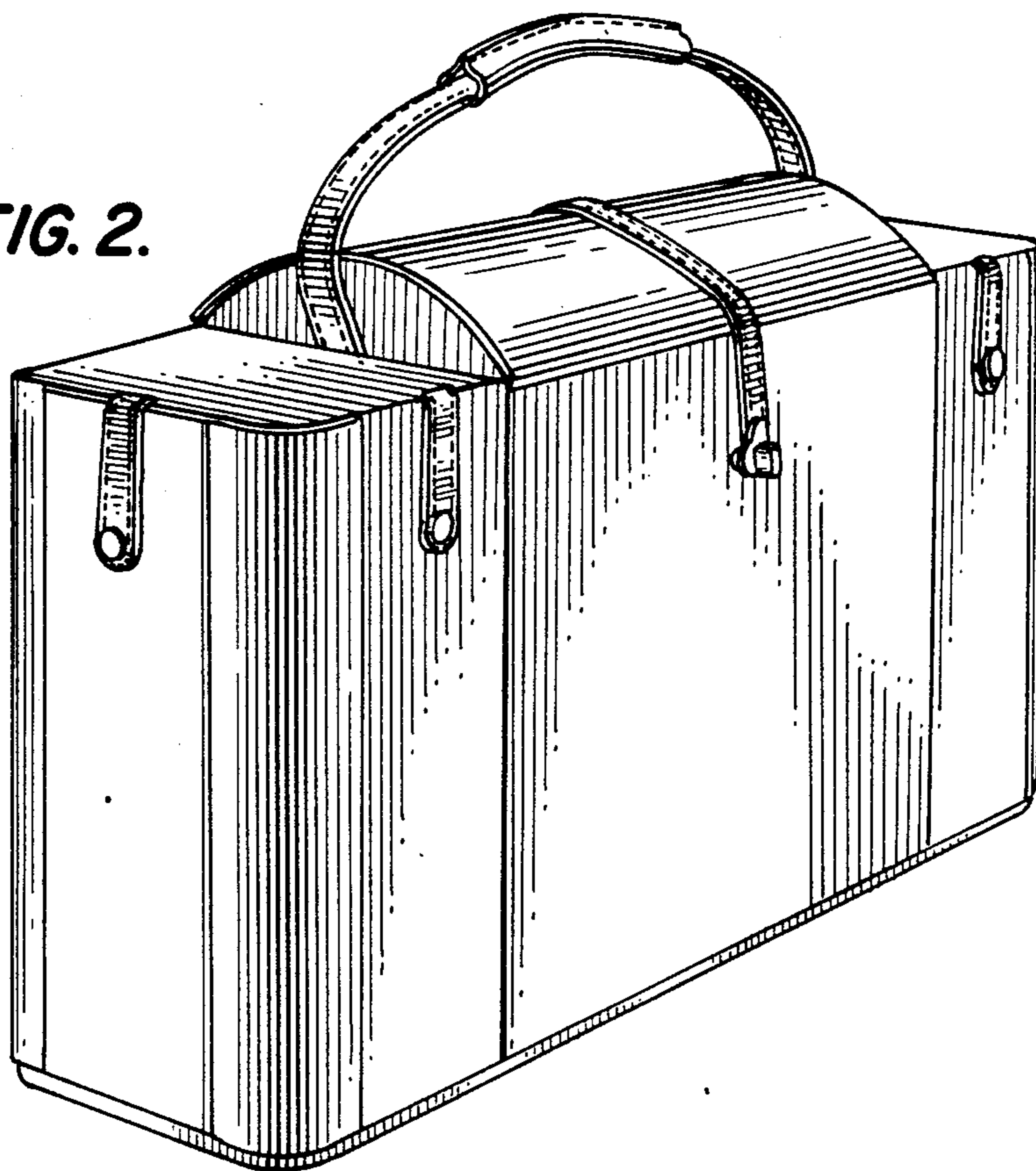

FIG. 4.

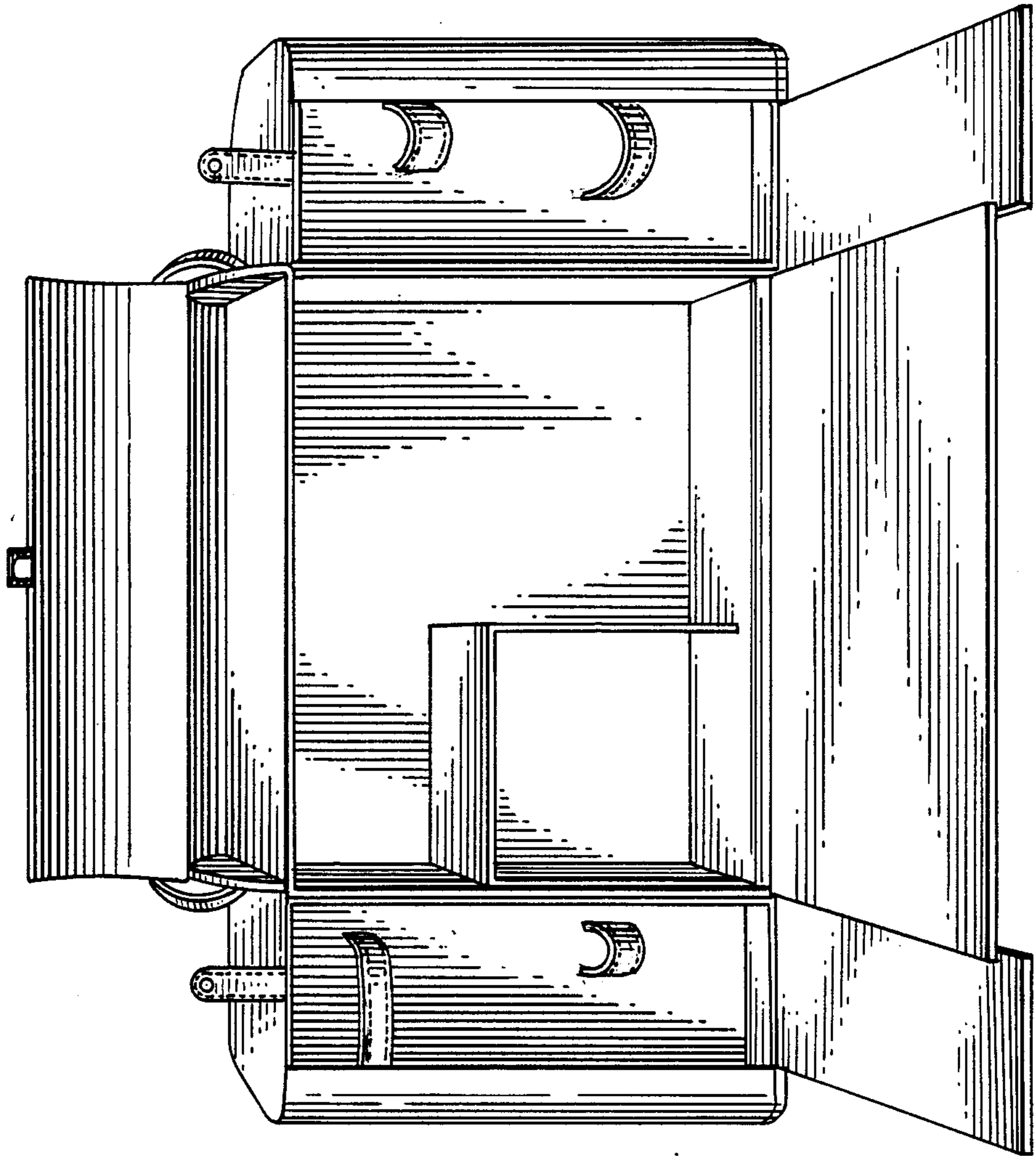
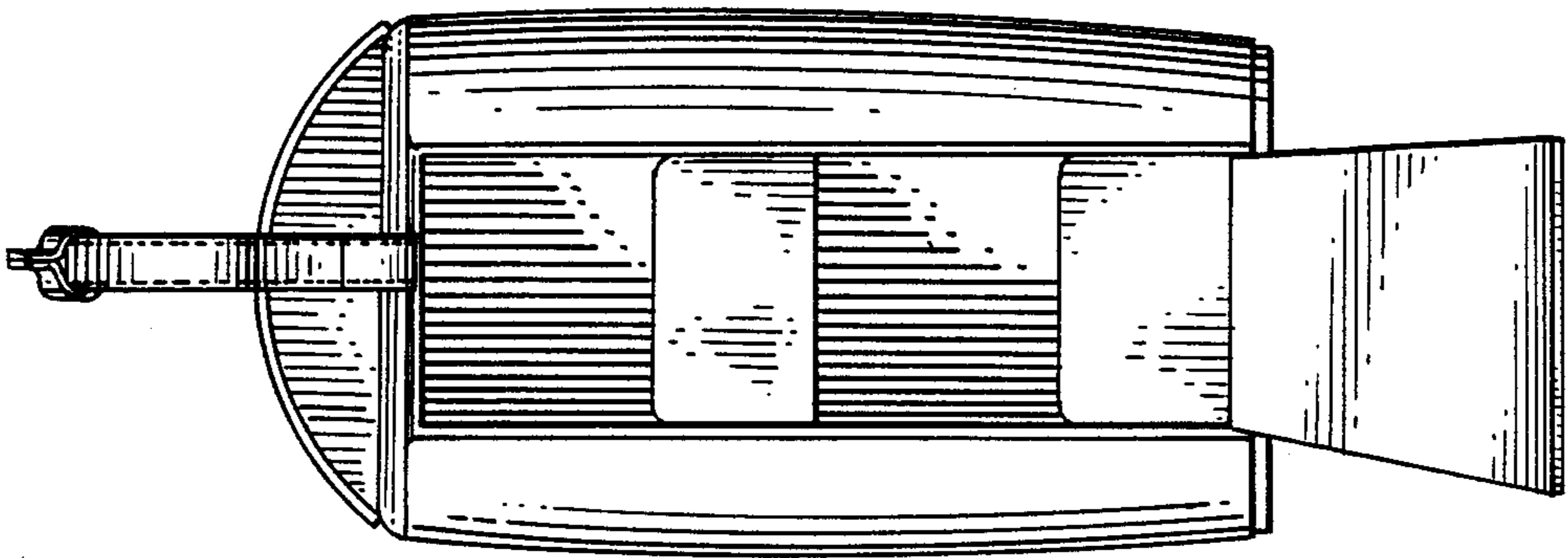
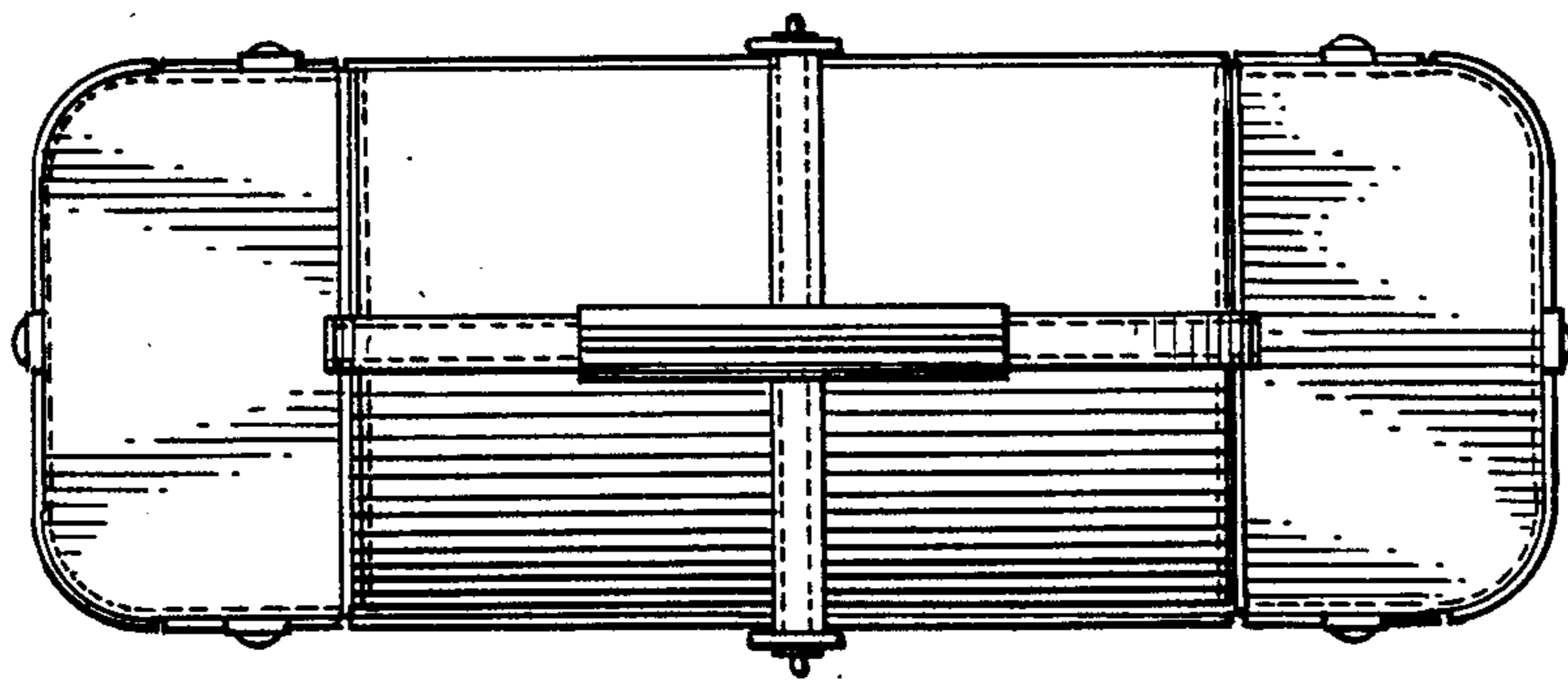
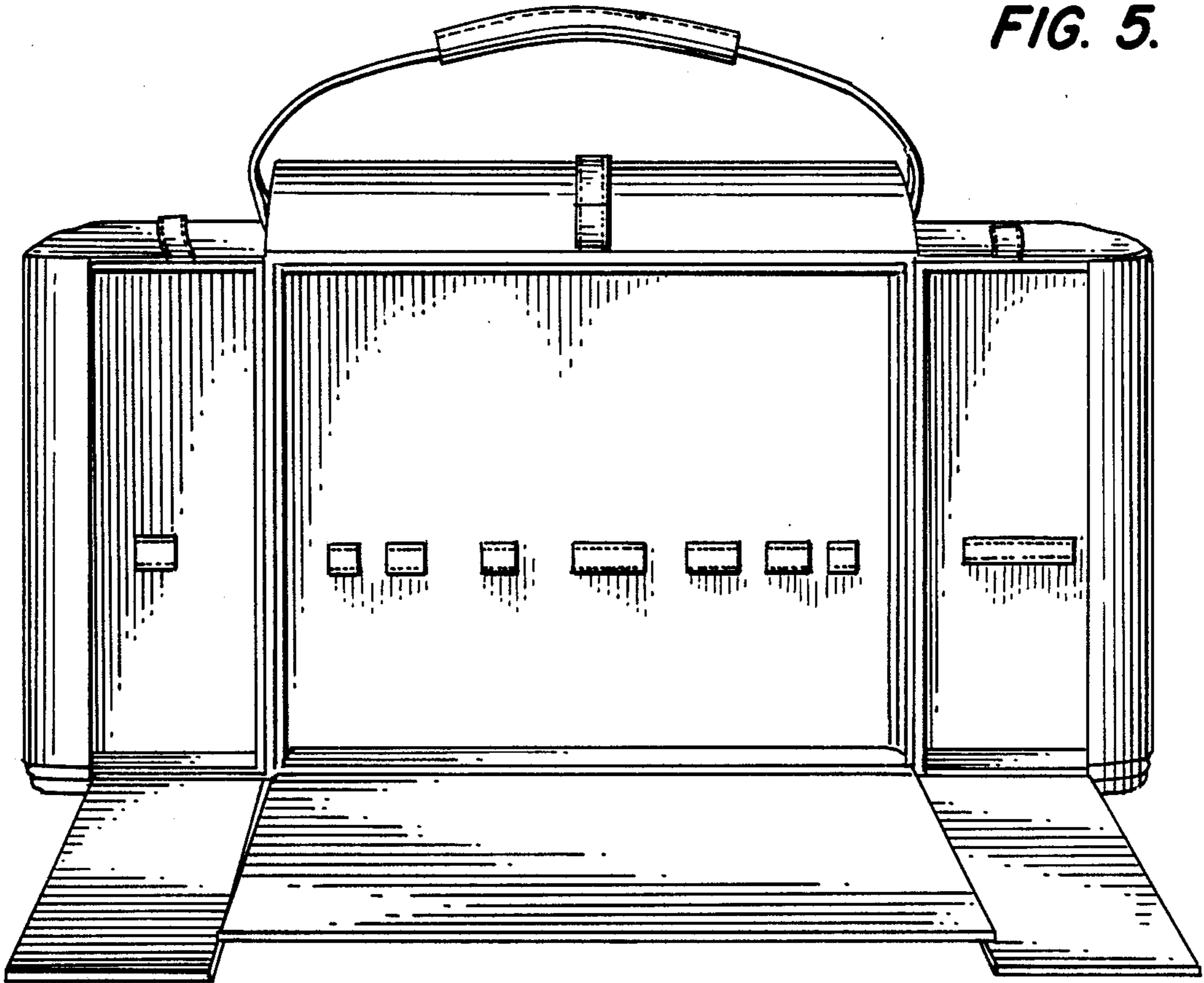

FIG. 3



*FIG. 5.*



*FIG. 7.*

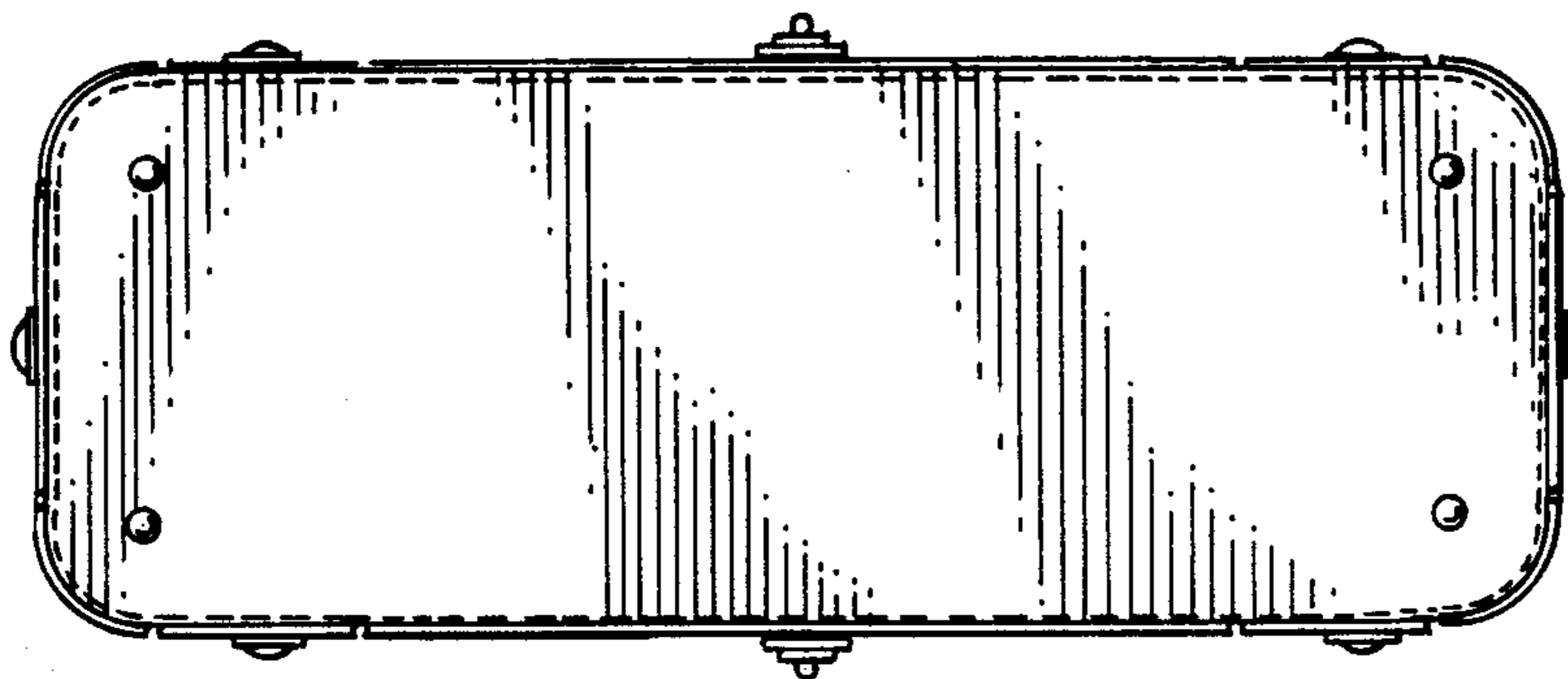

*FIG. 8.*

FIG. 6.

