

[54] **AUTOMOBILE**

[75] **Inventors: Masonori Imaki, Tokyo; Kenji Abe, Saitama; Yusuke Saitoh, Tokyo; Hideyuki Ikeda, Saitama, all of Japan**

[73] **Assignee: Honda Giken Kogyo Kabushiki Kaisha, Tokyo, Japan**

[**] **Term: 14 Years**

[21] **Appl. No.: 193,984**

[22] **Filed: May 13, 1988**

[52] **U.S. Cl. D12/92**

[58] **Field of Search D12/91, 92; 296/185**

[56] **References Cited**

U.S. PATENT DOCUMENTS

D. 301,436 6/1989 Mizuno et al. D12/92

OTHER PUBLICATIONS

Motor Trend, 5/87, pp. 78 & 80, Merkur Scorpio, bottom of page.

Primary Examiner—James M. Gandy
Attorney, Agent, or Firm—Lyon & Lyon

[57] **CLAIM**

The ornamental design for an automobile, as shown and described.

DESCRIPTION

FIG. 1 is a side elevation view of an automobile showing our new design, the opposite side being a mirror image thereof;

FIG. 2 is a front elevation view thereof;

FIG. 3 is a rear elevation view thereof; and

FIG. 4 is a top plan view thereof.

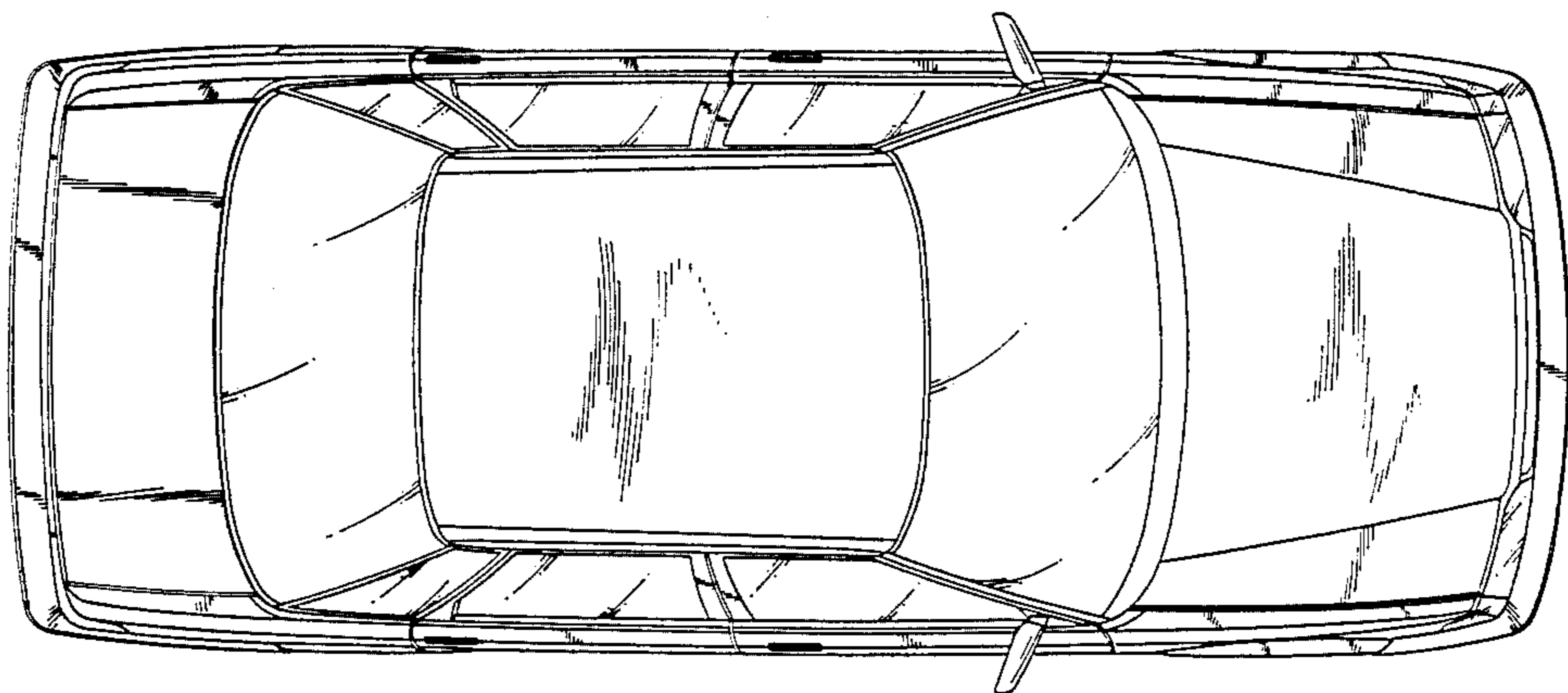
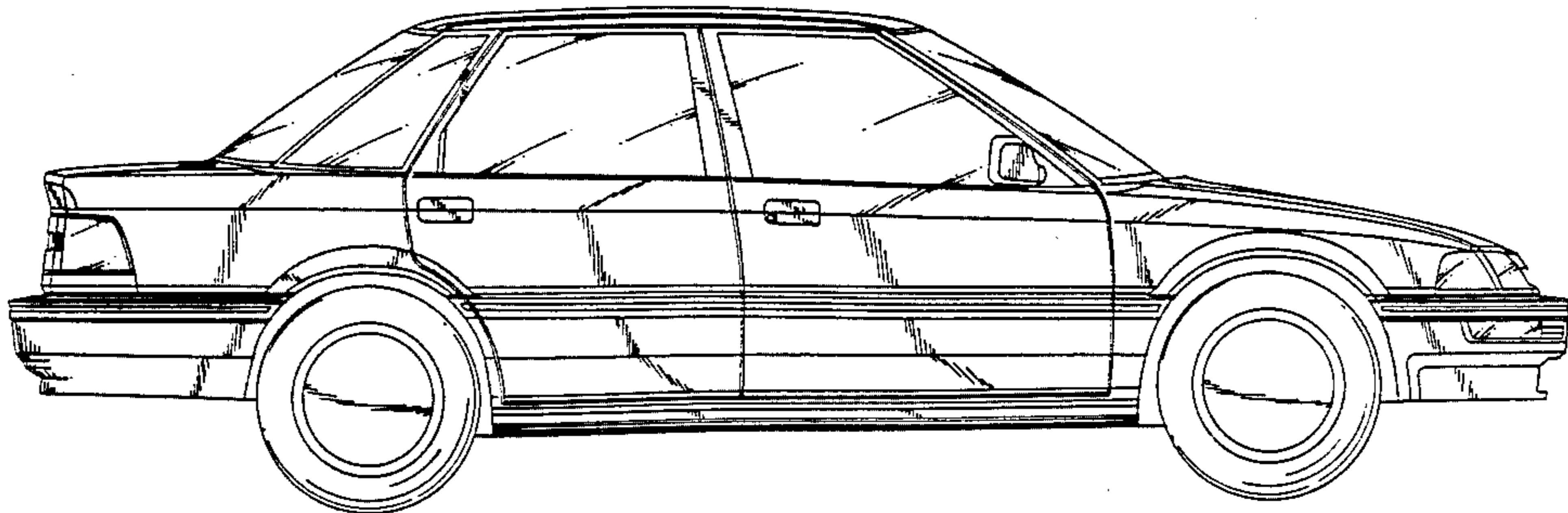

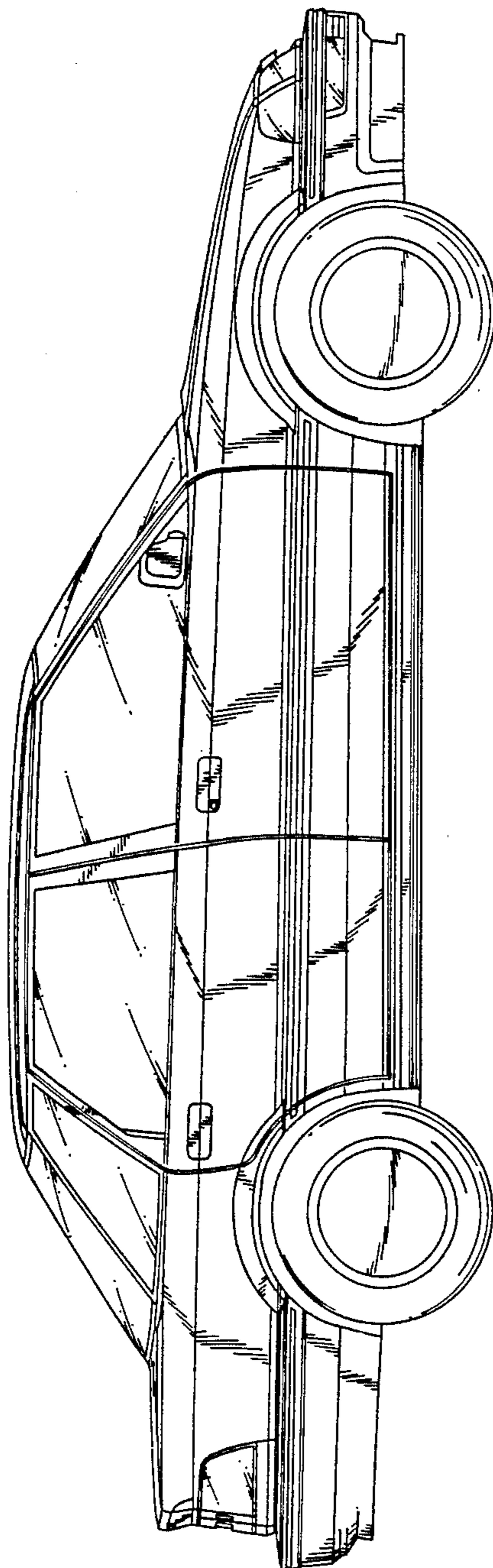

Fig. 1.

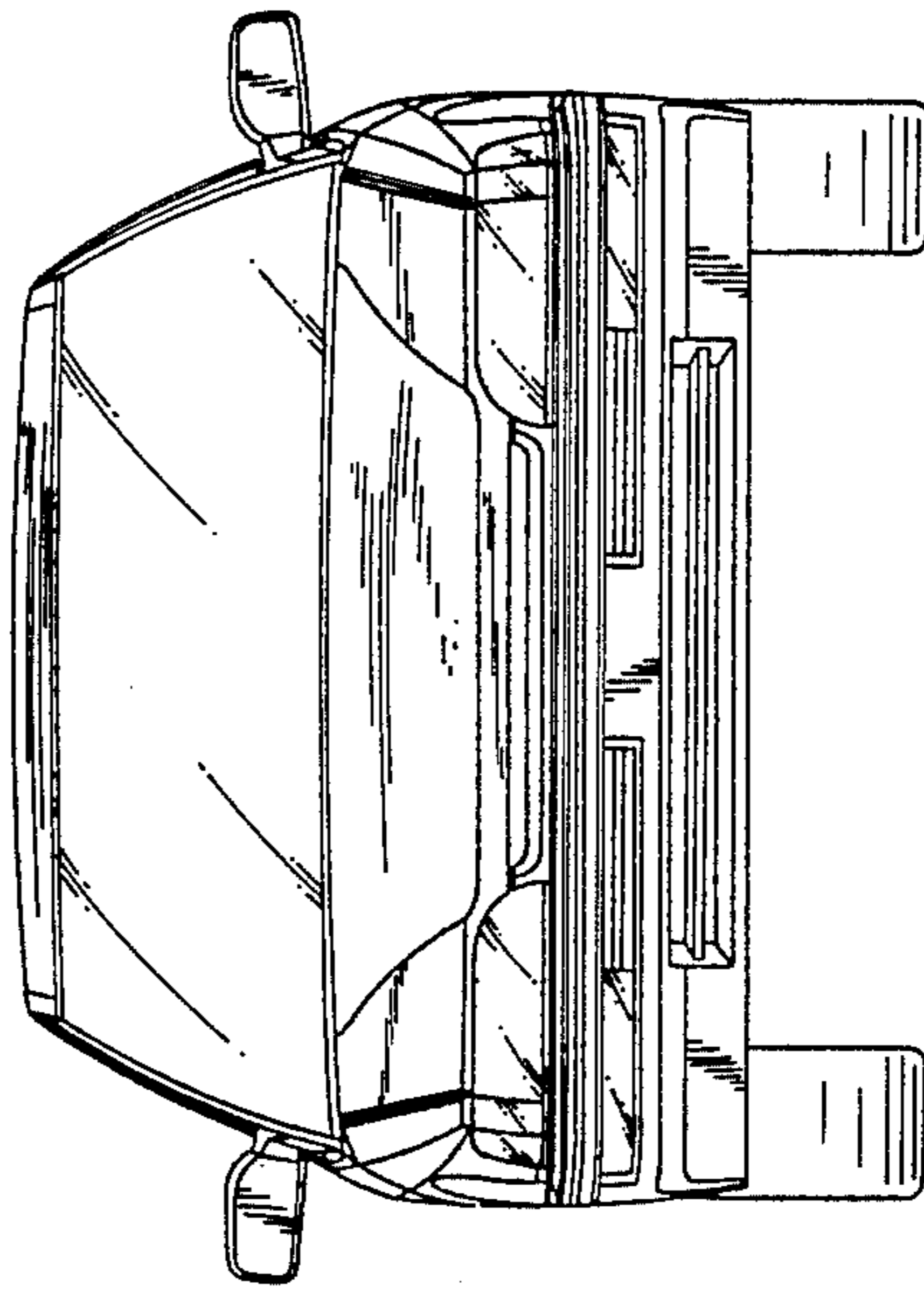

Fig. 2.

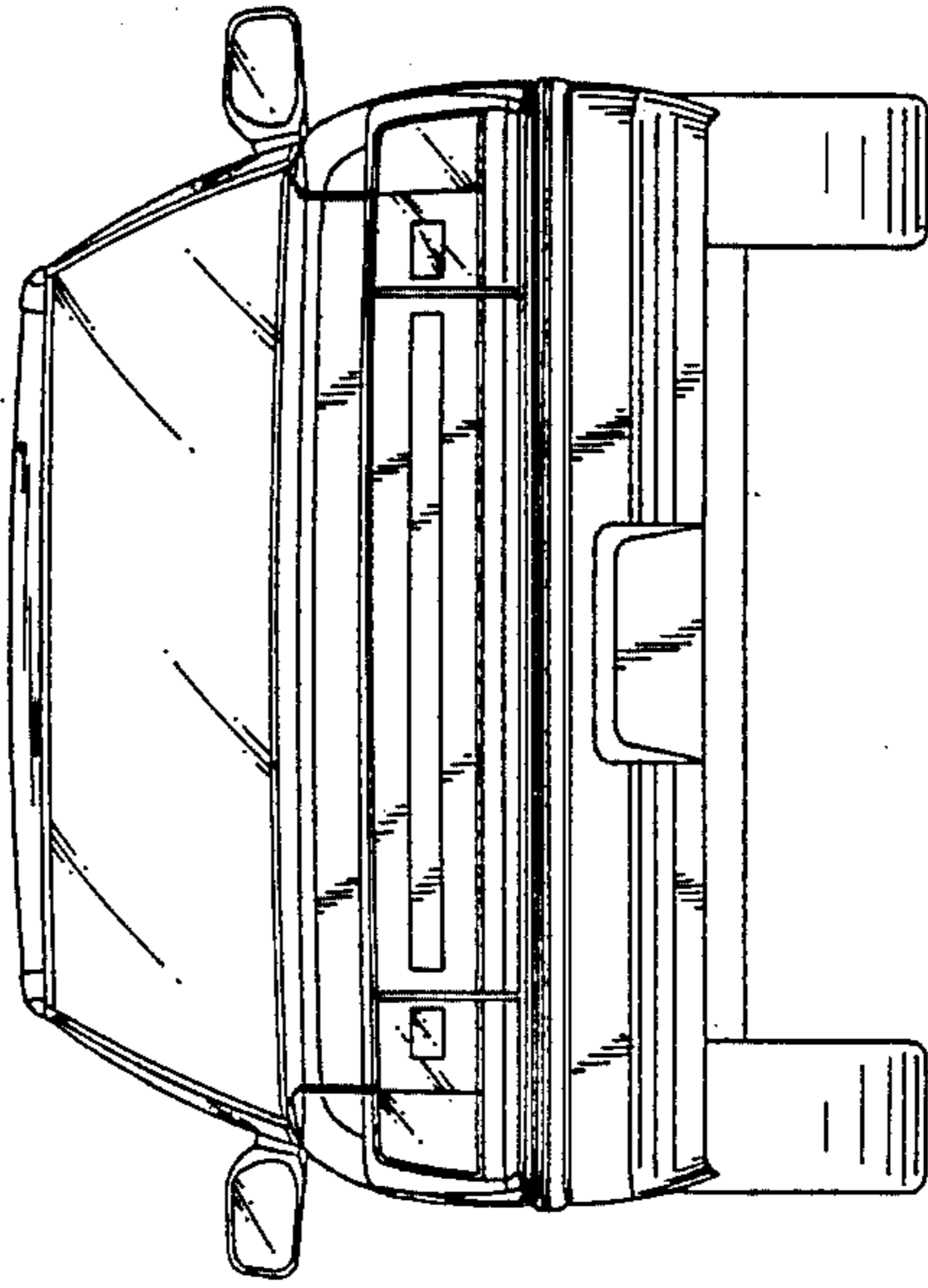

Fig. 3.

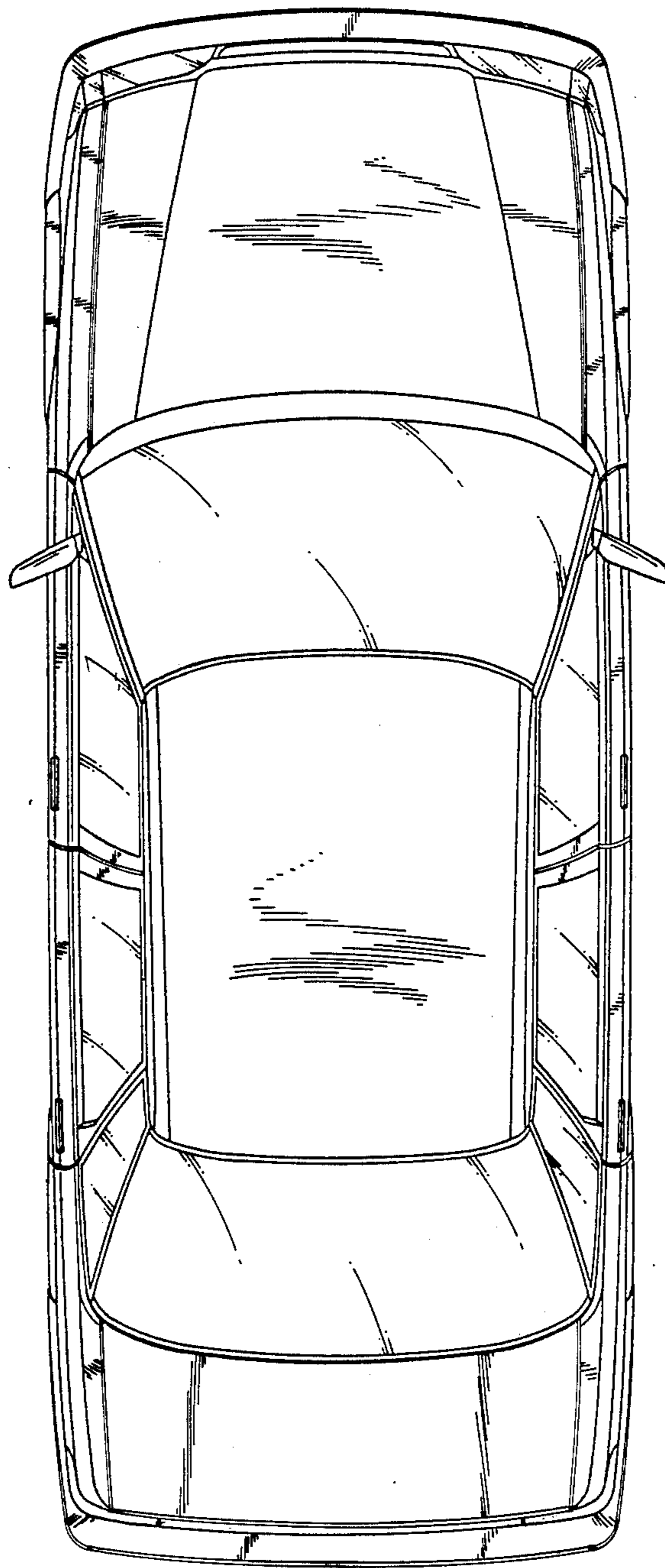

FIG. A.