

[54] VEHICLE LIFT

[75] Inventor: Shunji Isogai, Hekinan, Japan

[73] Assignee: Sugiyasu Industries Co., Ltd., Takahama, Japan

[\*\*] Term: 14 Years

[21] Appl. No.: 131,533

[22] Filed: Dec. 14, 1987

[30] Foreign Application Priority Data

Aug. 27, 1987 [JP] Japan ..... 62-35018

[52] U.S. Cl. .... D34/28; D34/31

[58] Field of Search ..... D34/28, 31; 254/89 R, 254/133 R, 2 B; 187/8.47, 8.75; D12/14

[56] References Cited

U.S. PATENT DOCUMENTS

4,679,660 7/1987 Suzuki ..... 254/89 R

4,763,761 8/1988 McKinsey et al. .... 254/89 R

4,776,569 10/1988 Nestel-Eichhausen ..... 254/89 R

4,825,977 5/1989 Isogai ..... 254/89 R

FOREIGN PATENT DOCUMENTS

2507168 12/1982 France ..... 254/2 B

Primary Examiner—Wallace R. Burke

Assistant Examiner—Kay H. Chin

Attorney, Agent, or Firm—Lahive & Cockfield

[57] CLAIM

The ornamental design for a vehicle lift, as shown.

DESCRIPTION

FIG. 1 is a front perspective view of a vehicle lift showing the new design.

FIG. 2 is a front elevational view thereof.

FIG. 3 is a rear elevational view thereof.

FIG. 4 is a top plan view thereof.

FIG. 5 is a bottom plan view thereof.

FIG. 6 is a left side elevational view thereof.

FIG. 7 is a right side elevational view thereof.

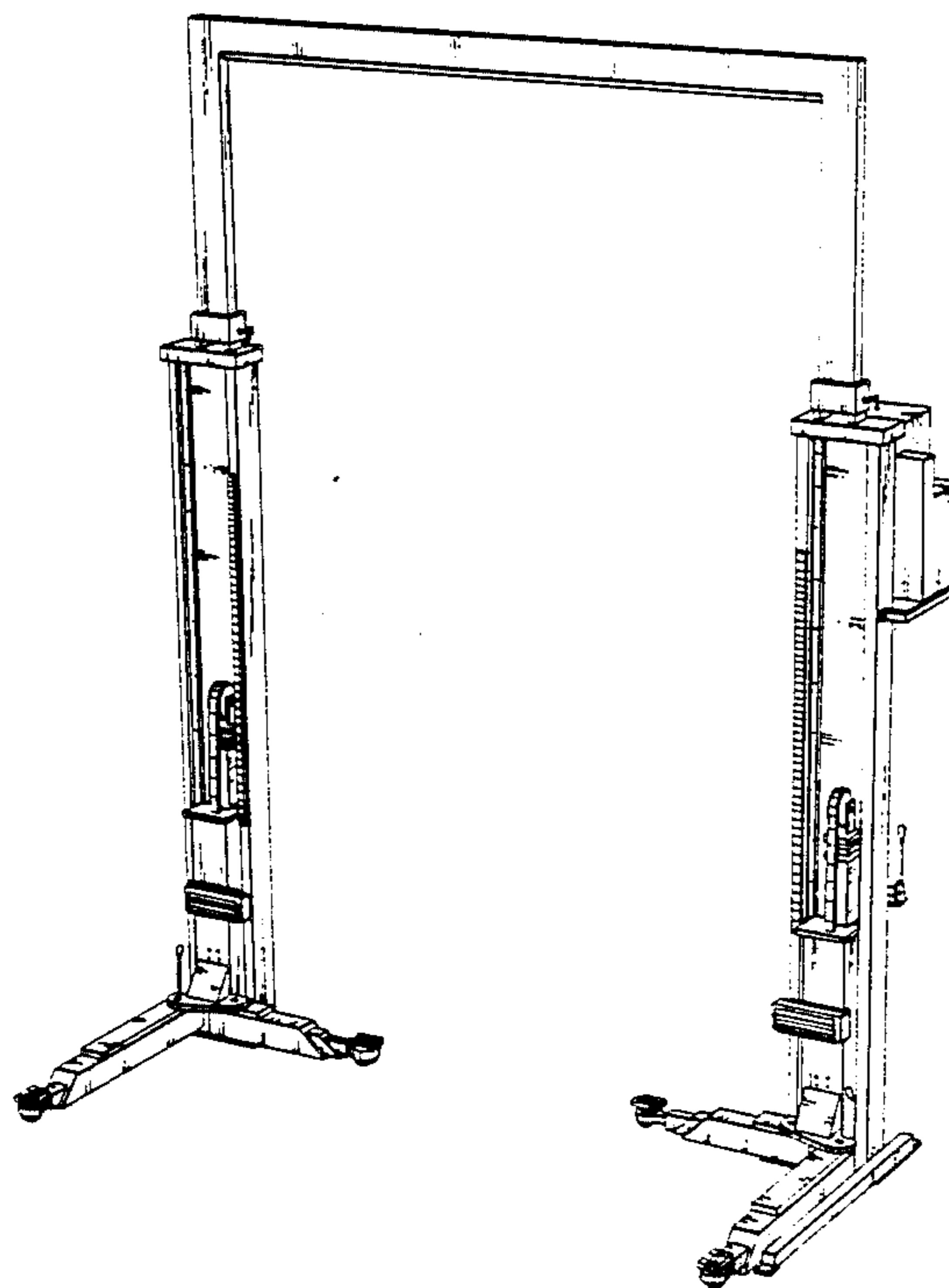

FIG. 1

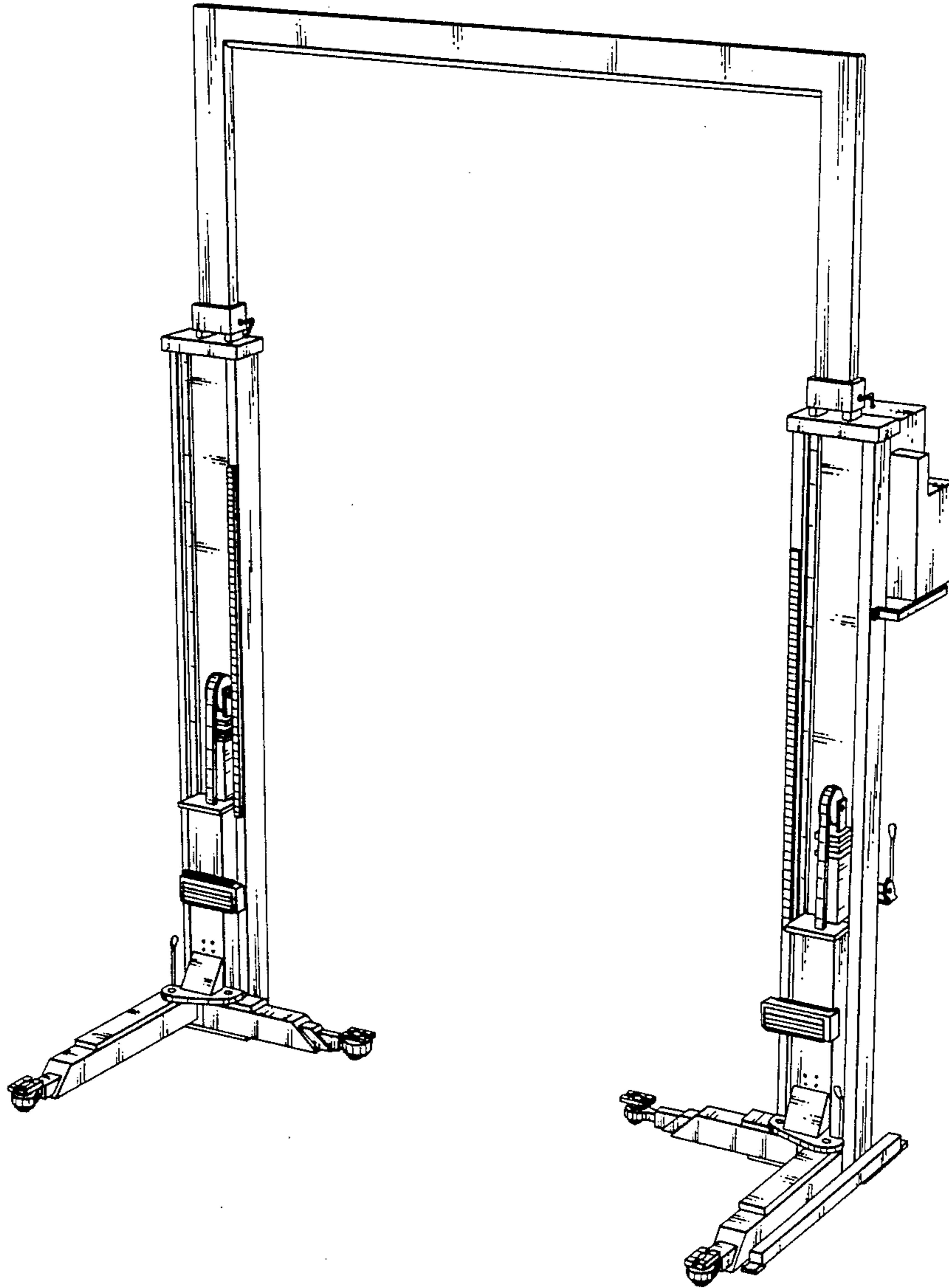

FIG. 2

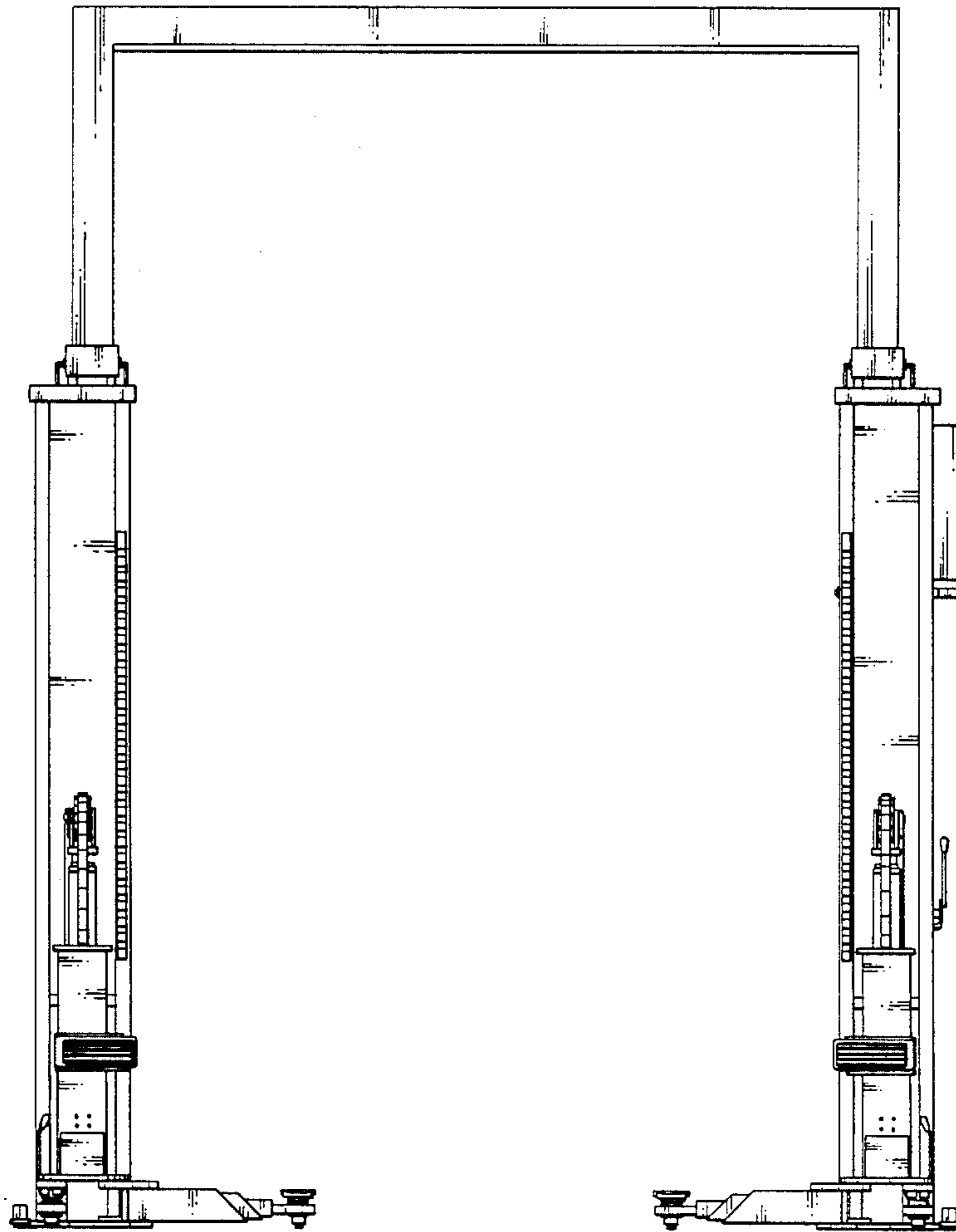

FIG. 3

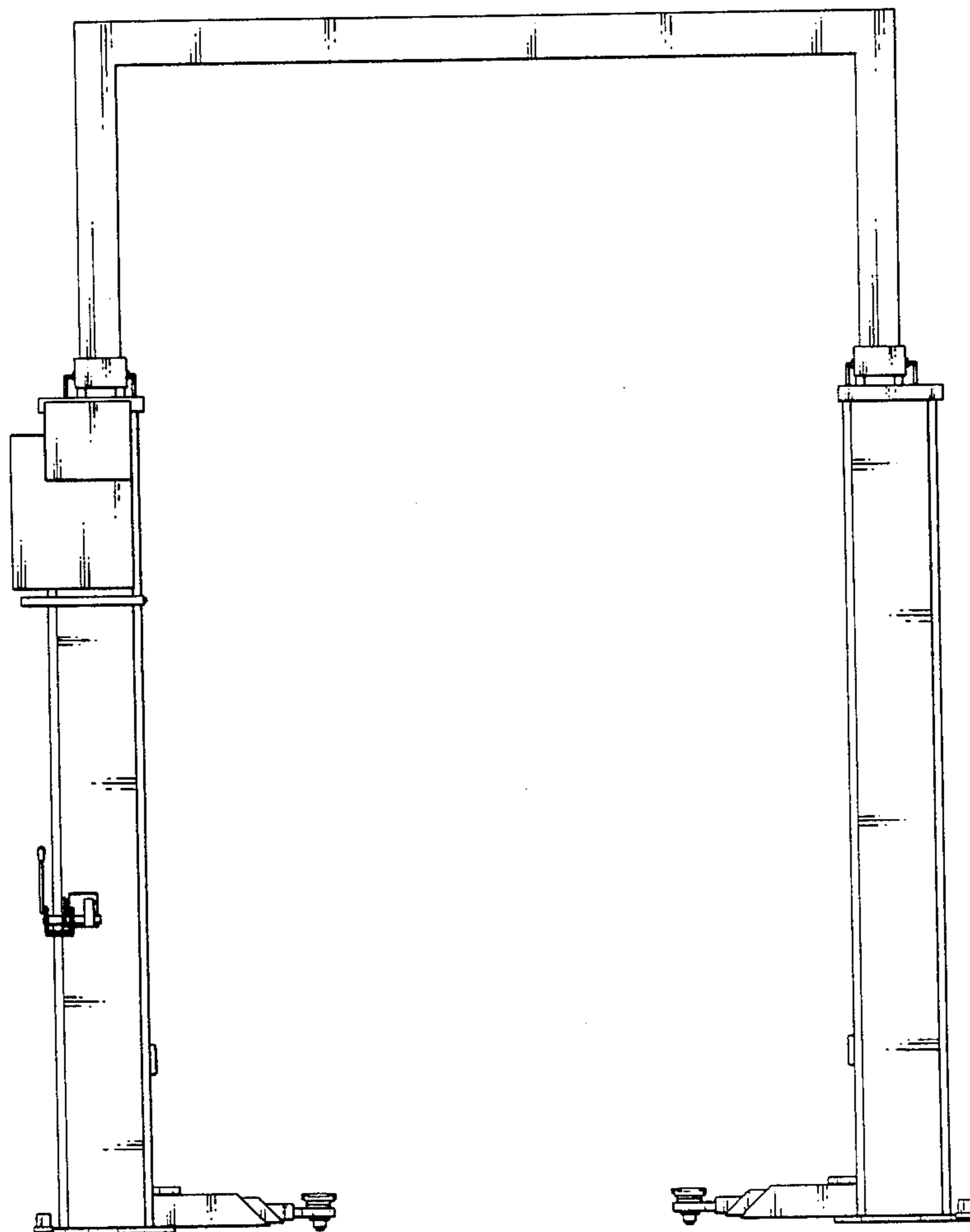

FIG. 4

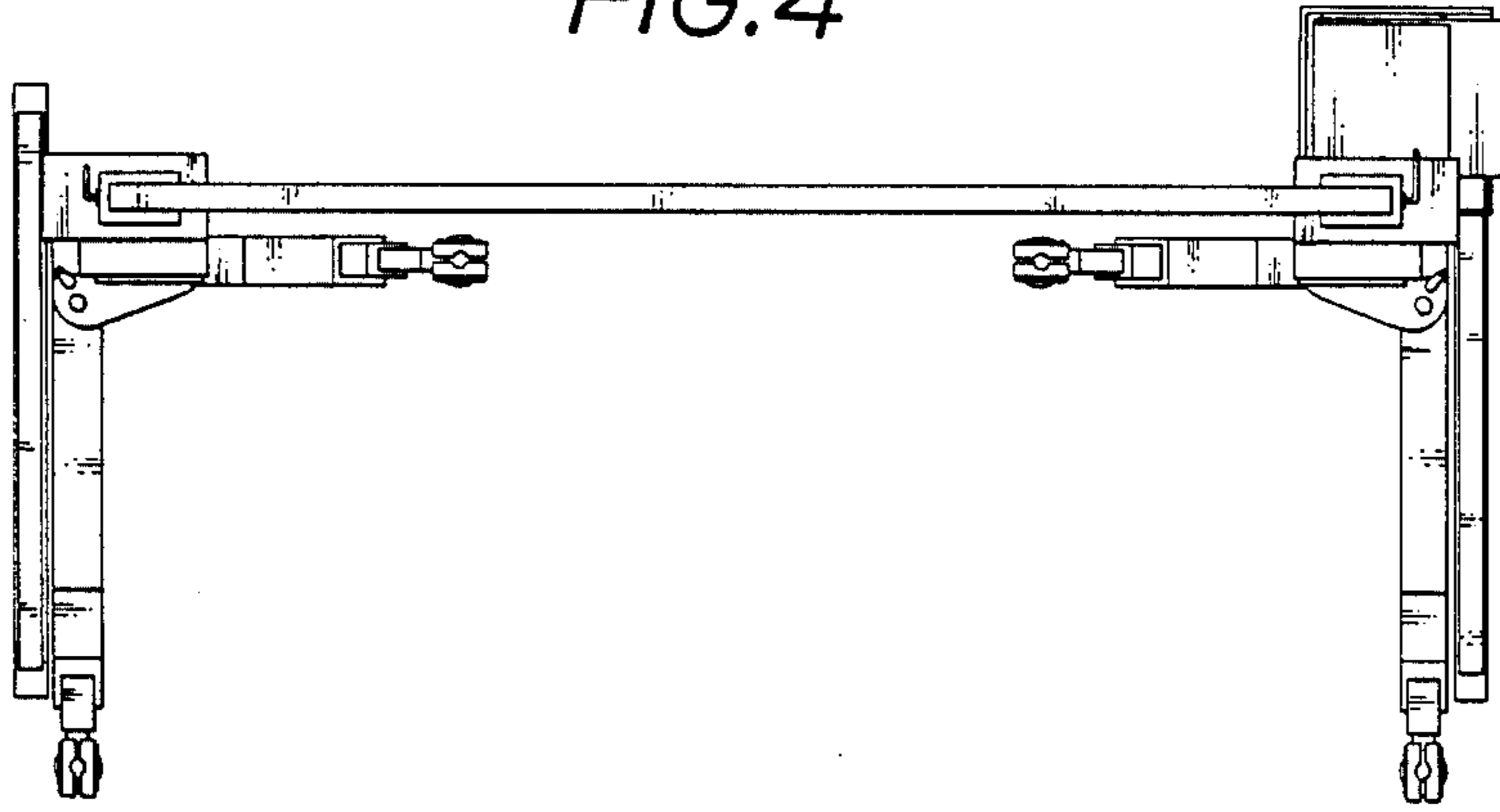

FIG. 5

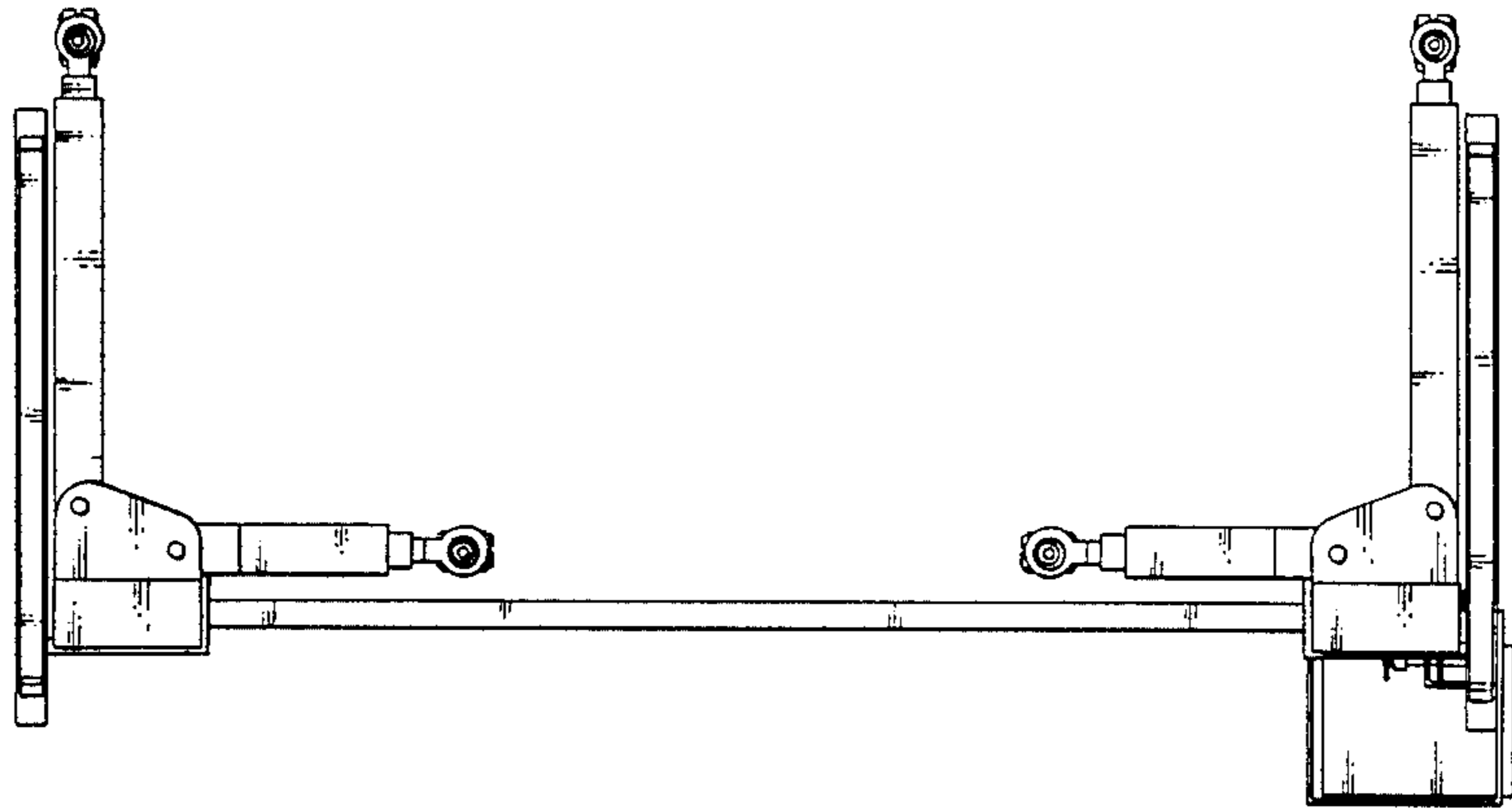

FIG. 6

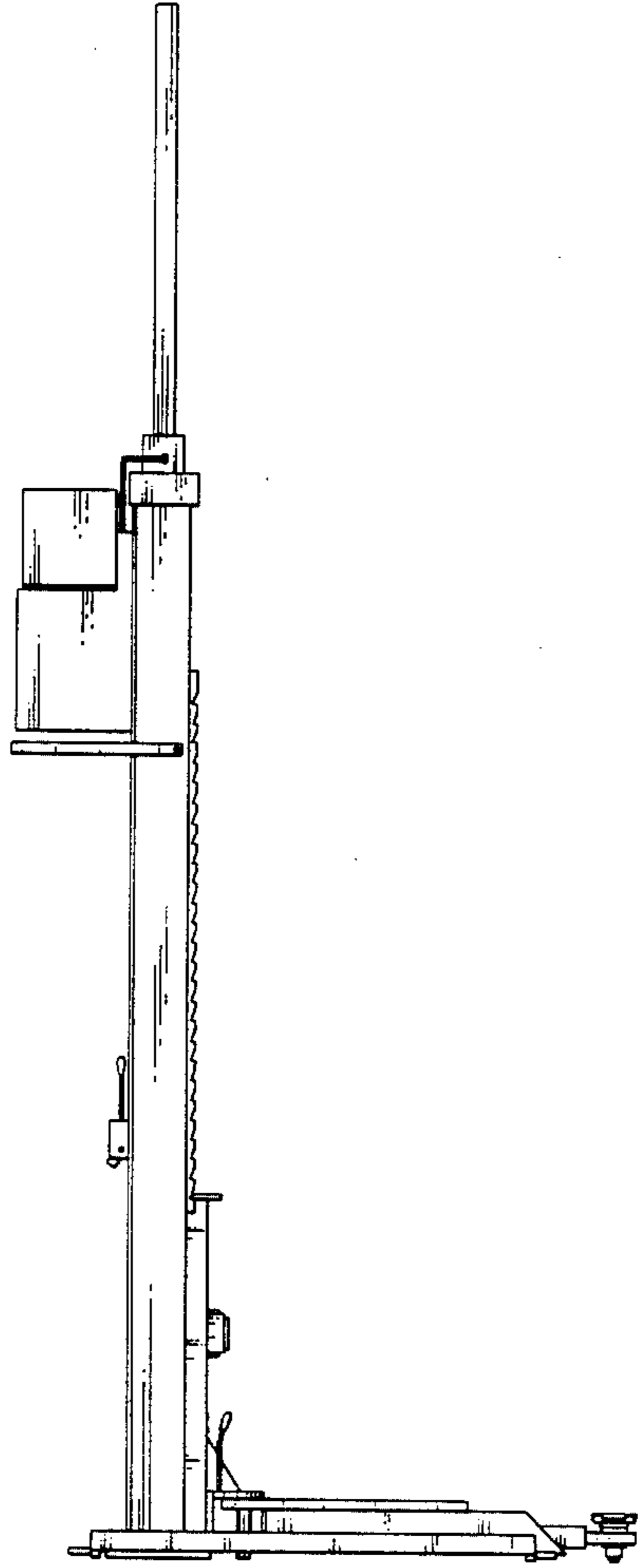

FIG. 7

