

[54] **ADVERTISING DISPLAY HOLDER FOR AN  
 AUTOMOBILE SUN VISOR**

[75] **Inventor: William P. Lothridge, Lorain, Ohio**

[73] **Assignee: Charles E. Mullinax, Amherst, Ohio**

[\*\*] **Term: 14 Years**

[21] **Appl. No.: 126,286**

[22] **Filed: Nov. 27, 1987**

[52] **U.S. Cl. .... D20/35**

[58] **Field of Search ..... D20/10, 42, 35; 40/584,  
 40/591, 593, 606, 617**

[56] **References Cited**

**U.S. PATENT DOCUMENTS**

1,931,016	10/1933	Bridges .....	40/606
2,382,875	8/1945	Handley .	
2,432,674	12/1947	Office .	
2,611,981	9/1952	Whitebread .....	40/617
2,825,988	3/1953	O'Reilly .	
2,916,838	12/1959	Campbell .....	40/593

2,931,114	4/1960	Peterson .	
3,809,428	5/1974	Cohen .	
3,903,629	9/1975	Gruna .	
4,208,820	6/1980	Cole .....	40/591

*Primary Examiner*—Wallace R. Burke  
*Assistant Examiner*—Marcus Jackson  
*Attorney, Agent, or Firm*—Pearne, Gordon, McCoy & Granger

[57] **CLAIM**

The ornamental design of an advertising display holder for an automobile sun visor, as shown and described.

**DESCRIPTION**

FIG. 1 is a front elevational view of an advertising display holder for an automobile sun visor showing my new design, with the display in use and the broken lines shown for illustrative purposes only and forming no part of the claimed design;

FIG. 2 is a front elevational view thereof, with the rear elevational view being a mirror image thereof;

FIG. 3 is a right side elevational view thereof, with the left side being a mirror image thereof.

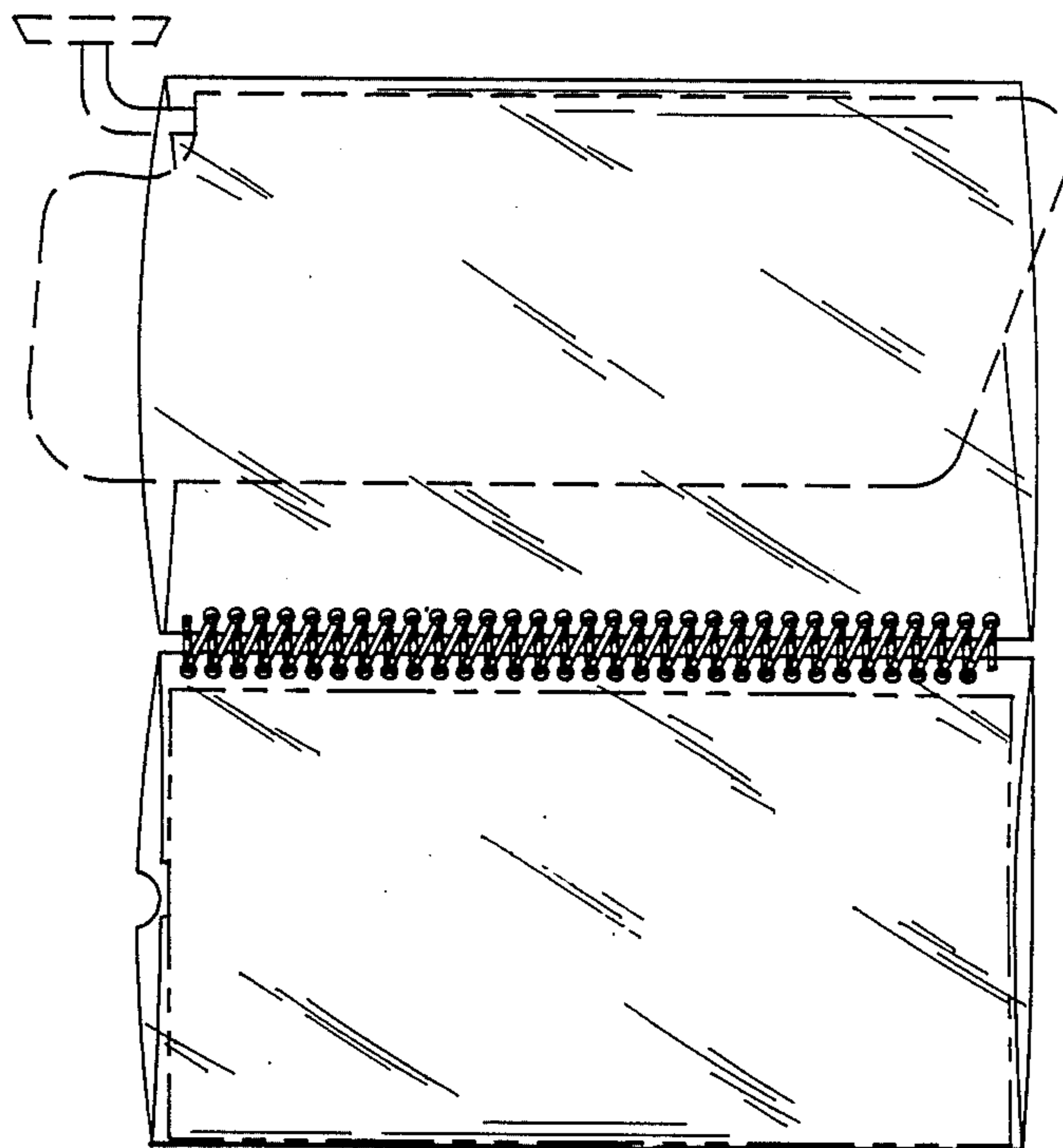

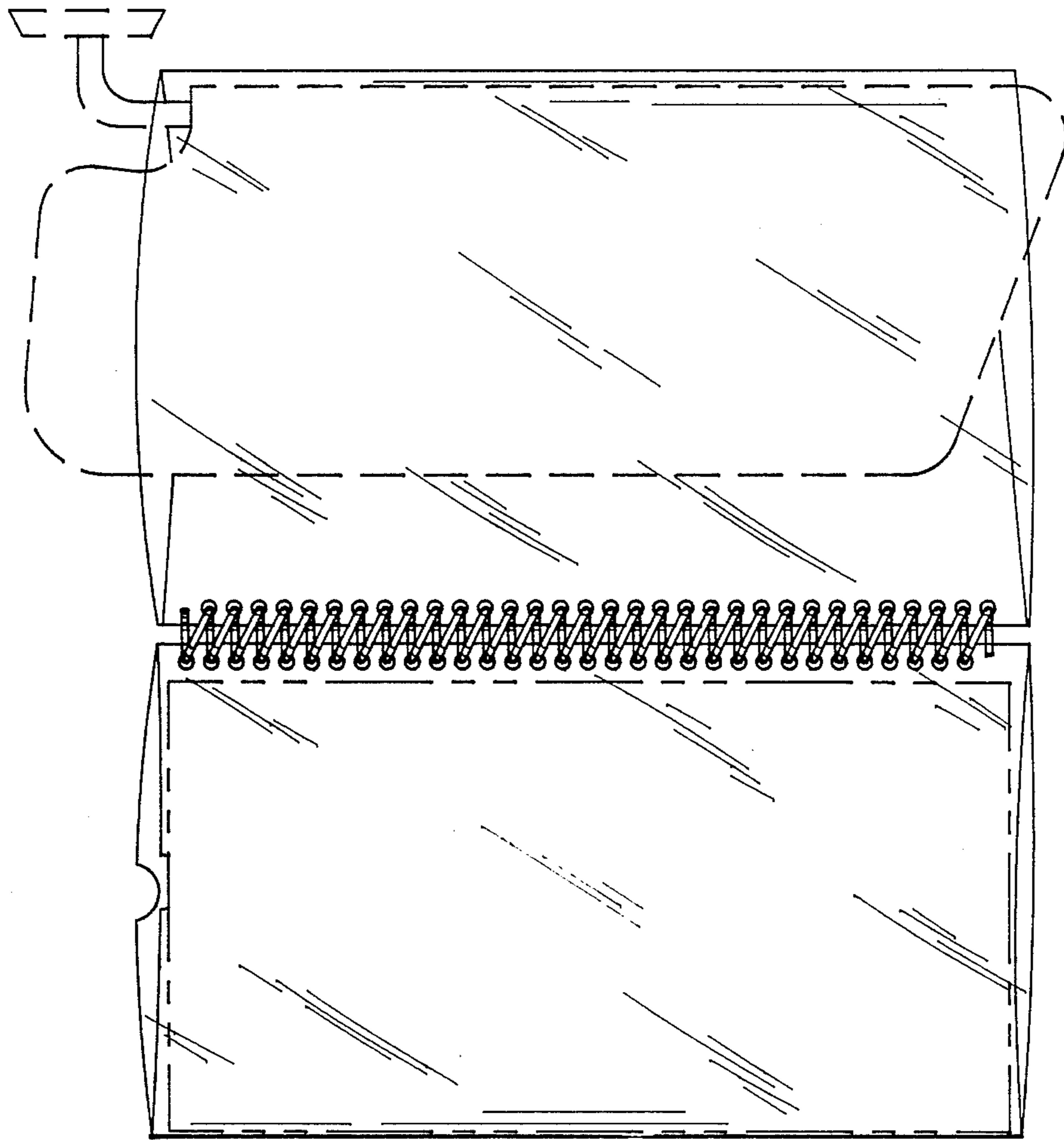

Fig. 1

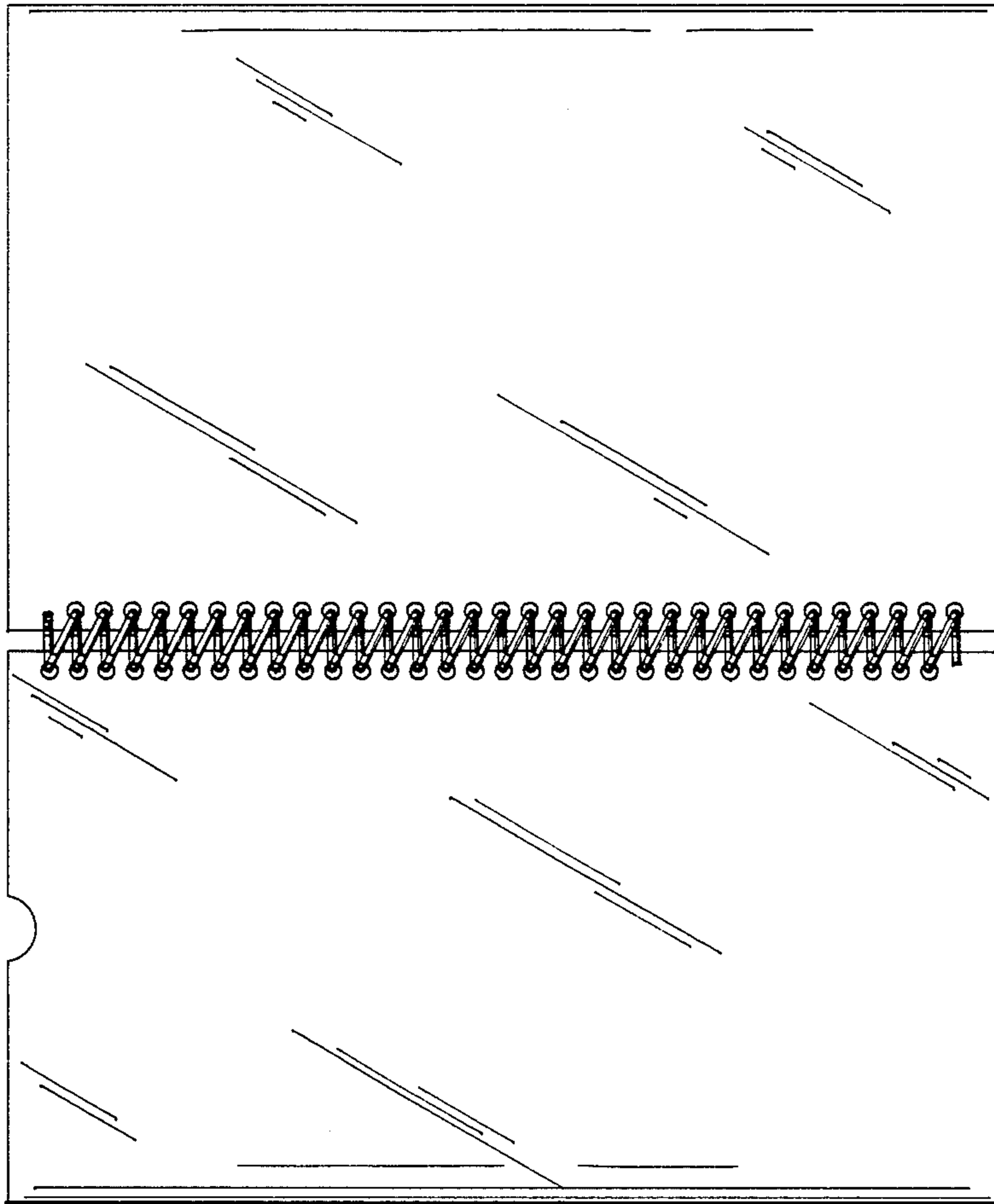

Fig. 2



Fig. 3