

[54] GUITAR PICK HOLDER

[76] Inventor: Casey N. Gervase, 33 Longnecker St., Buffalo, N.Y. 14206

[**] Term: 14 Years

[21] Appl. No.: 279,133

[22] Filed: Dec. 2, 1988

[52] U.S. Cl. D3/30.1; 84/329; D17/20

[58] Field of Search 84/453, 320, 321, 322, 84/329; D17/20; D3/30.1, 99, 100; D9/434, 444, 455; D27/172, 173, 176, 183, 186, 193; 150/162; 206/14, 314; 190/108

[56] References Cited

U.S. PATENT DOCUMENTS

| | | | | |
|------------|---------|--------------|-------|--------|
| D. 237,561 | 11/1975 | Kesner | | D3/100 |
| D. 296,267 | 6/1988 | Sakai | | D3/100 |
| 570,321 | 10/1896 | Mahler | | 84/329 |
| 1,570,905 | 1/1926 | Martell | | 84/329 |
| 1,645,918 | 10/1927 | Miele | | 84/329 |
| 3,181,410 | 5/1965 | Phillips | | 84/322 |
| 4,135,431 | 1/1979 | Ferguson | | 84/329 |
| 4,248,128 | 2/1981 | Des Gaines | | D17/20 |
| 4,467,693 | 8/1984 | Nasfell, Jr. | | 84/329 |
| 4,785,708 | 11/1988 | Vaughn | | 84/329 |
| 4,790,232 | 12/1988 | Rosen | | 84/322 |

OTHER PUBLICATIONS

David Wexler & Co. Catalog #66; 1965-1966; p. 137. The Music Trades; Apr. 1972. The Music Trades; Mar. 1, 1924; p. 32; The Grover Pick Holder advertisement.

Primary Examiner—James R. Largen
Assistant Examiner—Cathy Anne MacCormac
Attorney, Agent, or Firm—Richard C. Litman

[57] CLAIM

The ornamental design for a guitar pick holder, as shown and described.

DESCRIPTION

FIG. 1 is a top front and right side perspective view of a guitar pick holder showing my new design, the right side being broken away for purposes of illustration; FIG. 2 is a front elevational view thereof; FIG. 3 is a right side elevational view thereof, the left side being a mirror image of the right side shown; FIG. 4 is a rear elevational view thereof; FIG. 5 is a top plan view thereof; and FIG. 6 is a bottom plan view thereof. FIG. 7 is another perspective view thereof, the right side being broken away for purposes of illustration. The broken line representation of a strap or belt in FIGS. 1 and 7 and guitar picks in FIGS. 5, 6 and 7 are for illustrative purposes only and form no part of the claimed design.

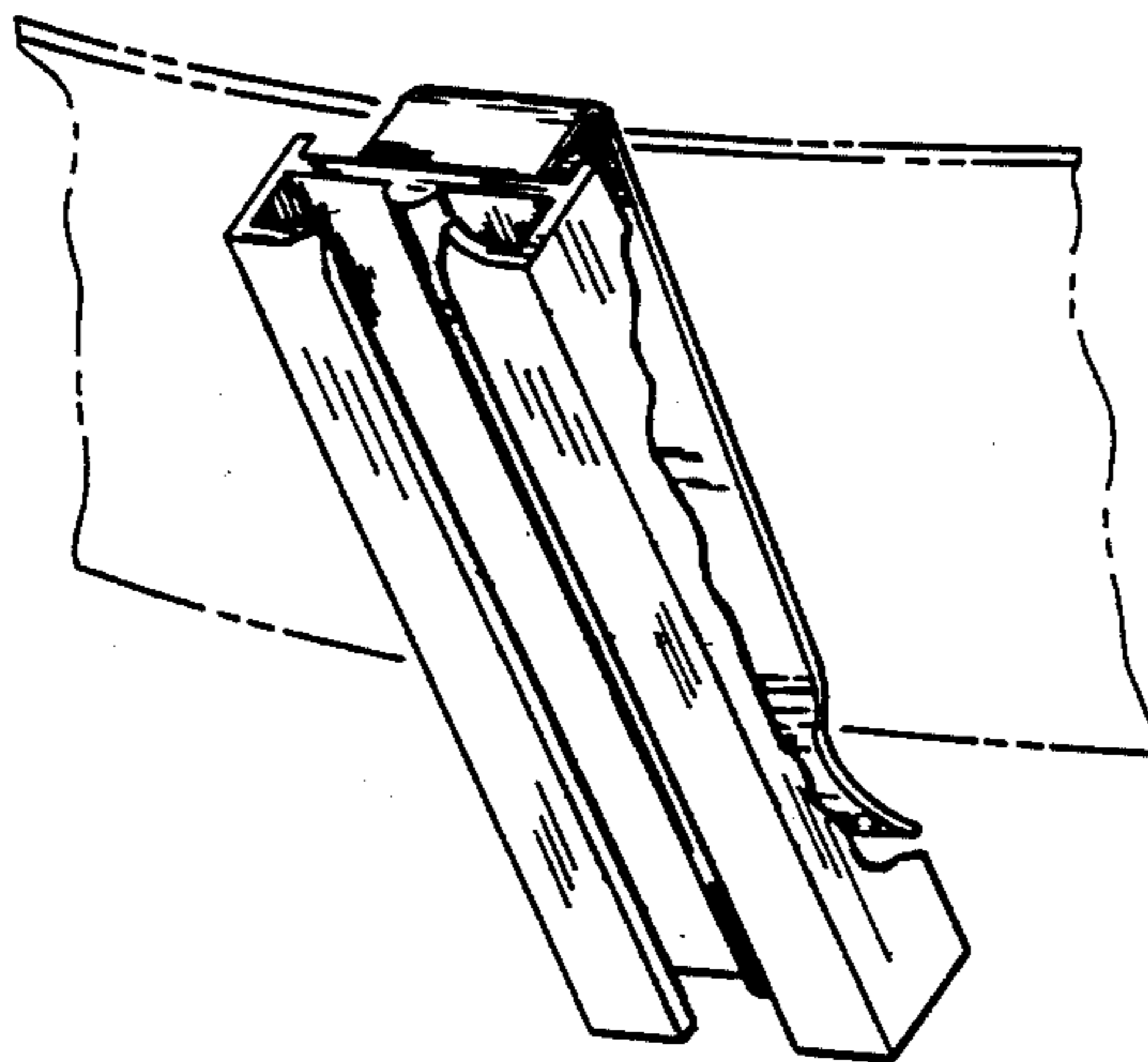

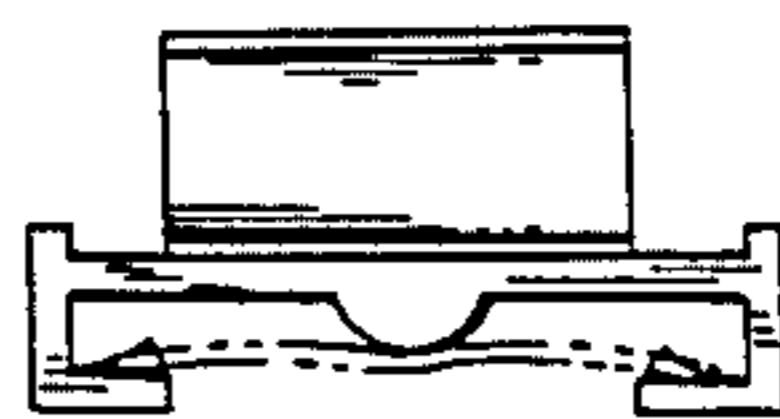
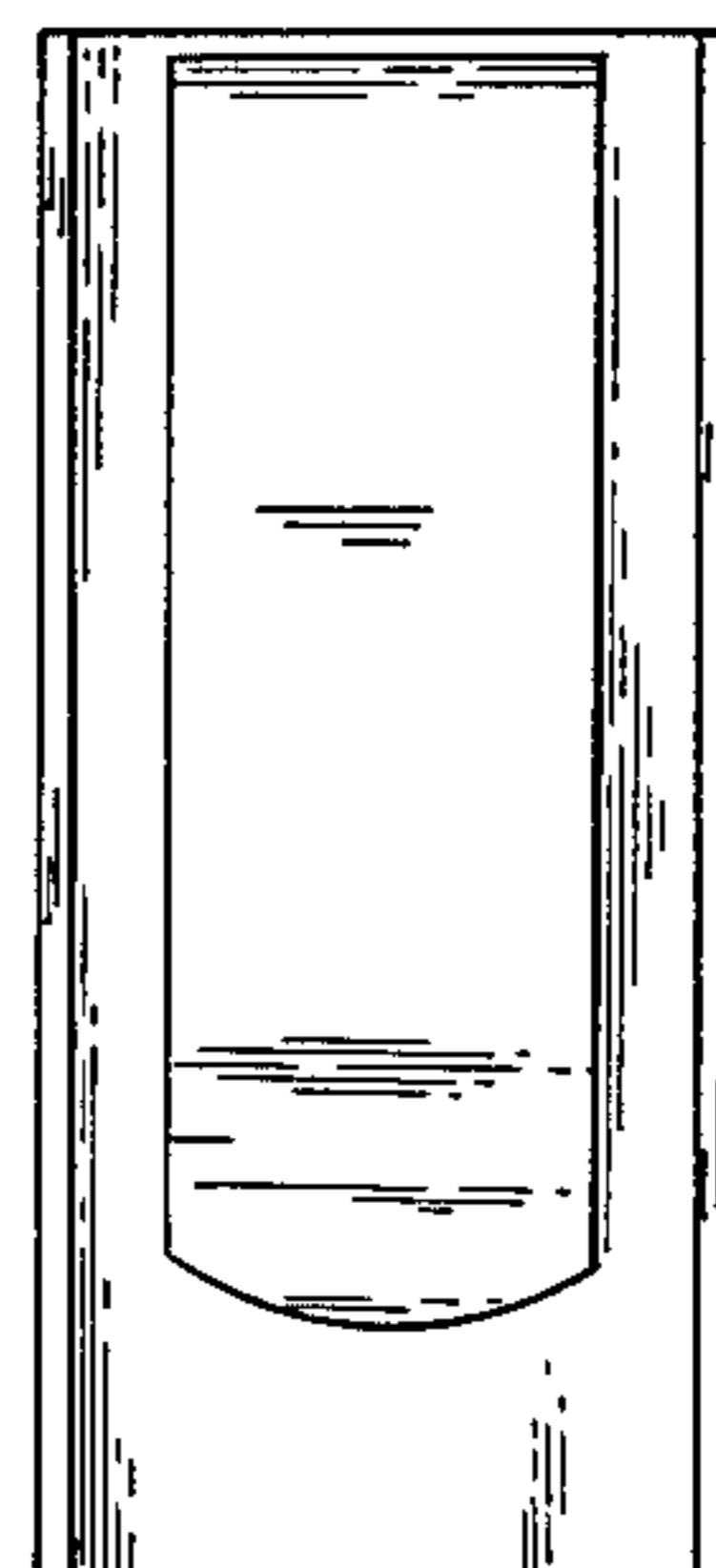
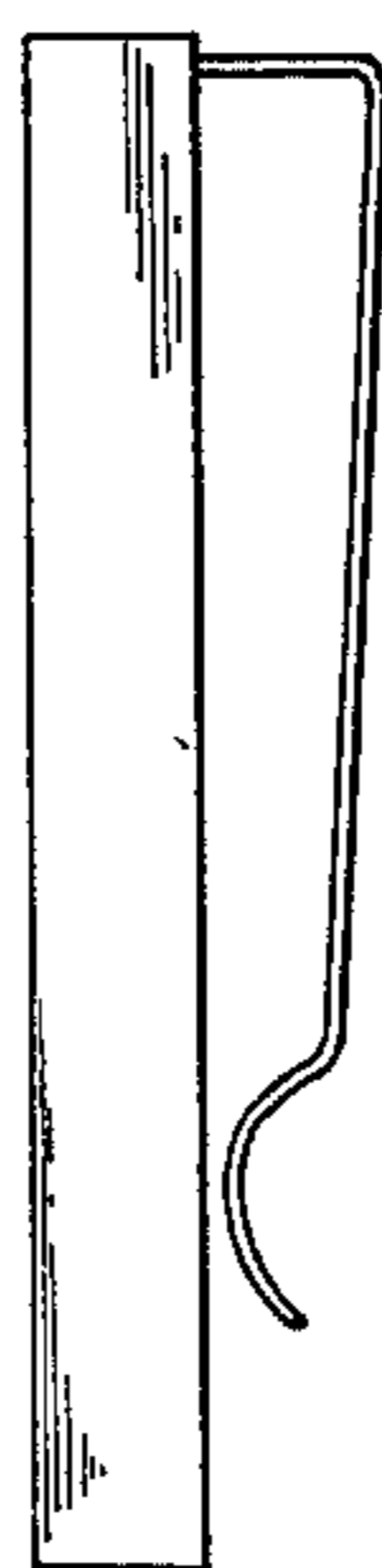
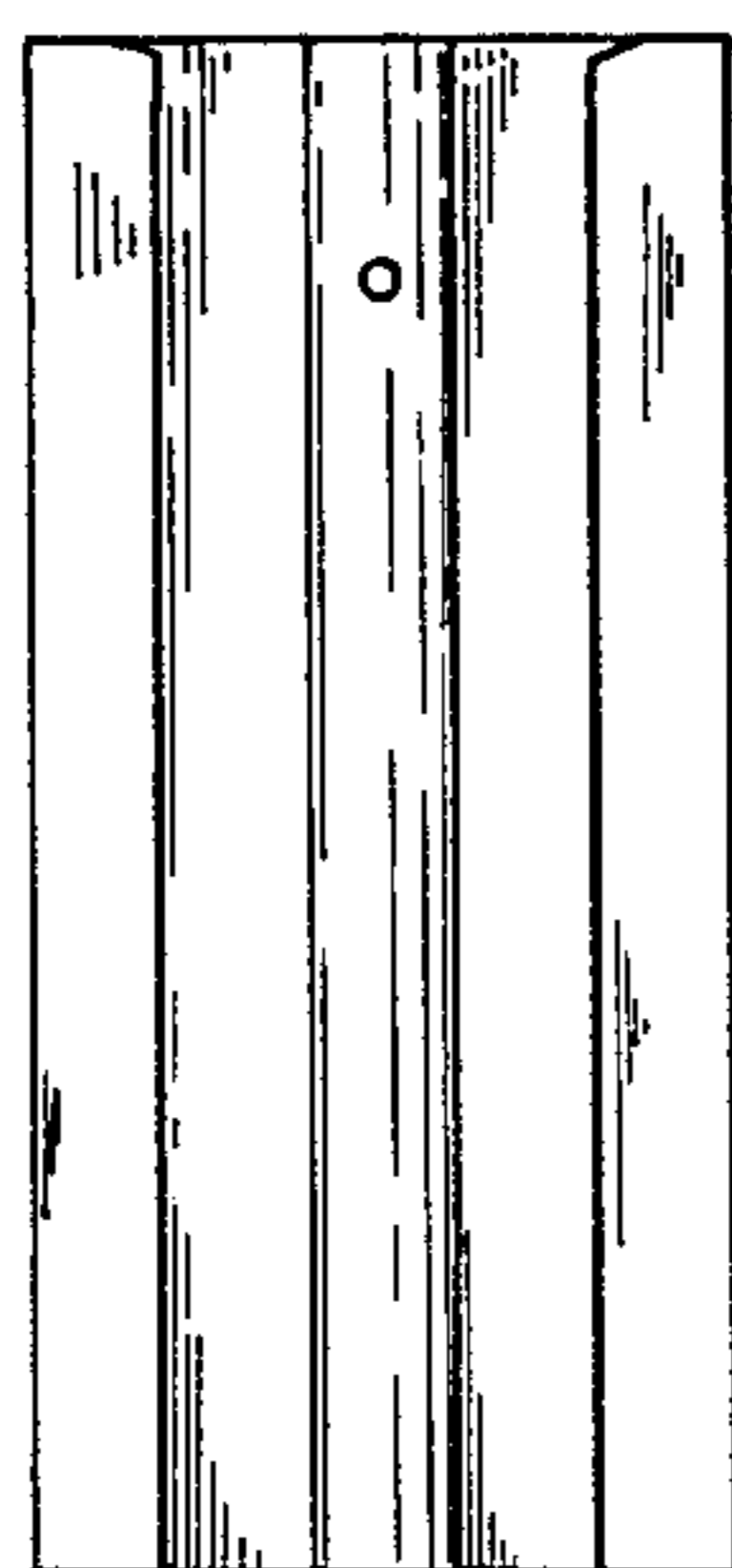
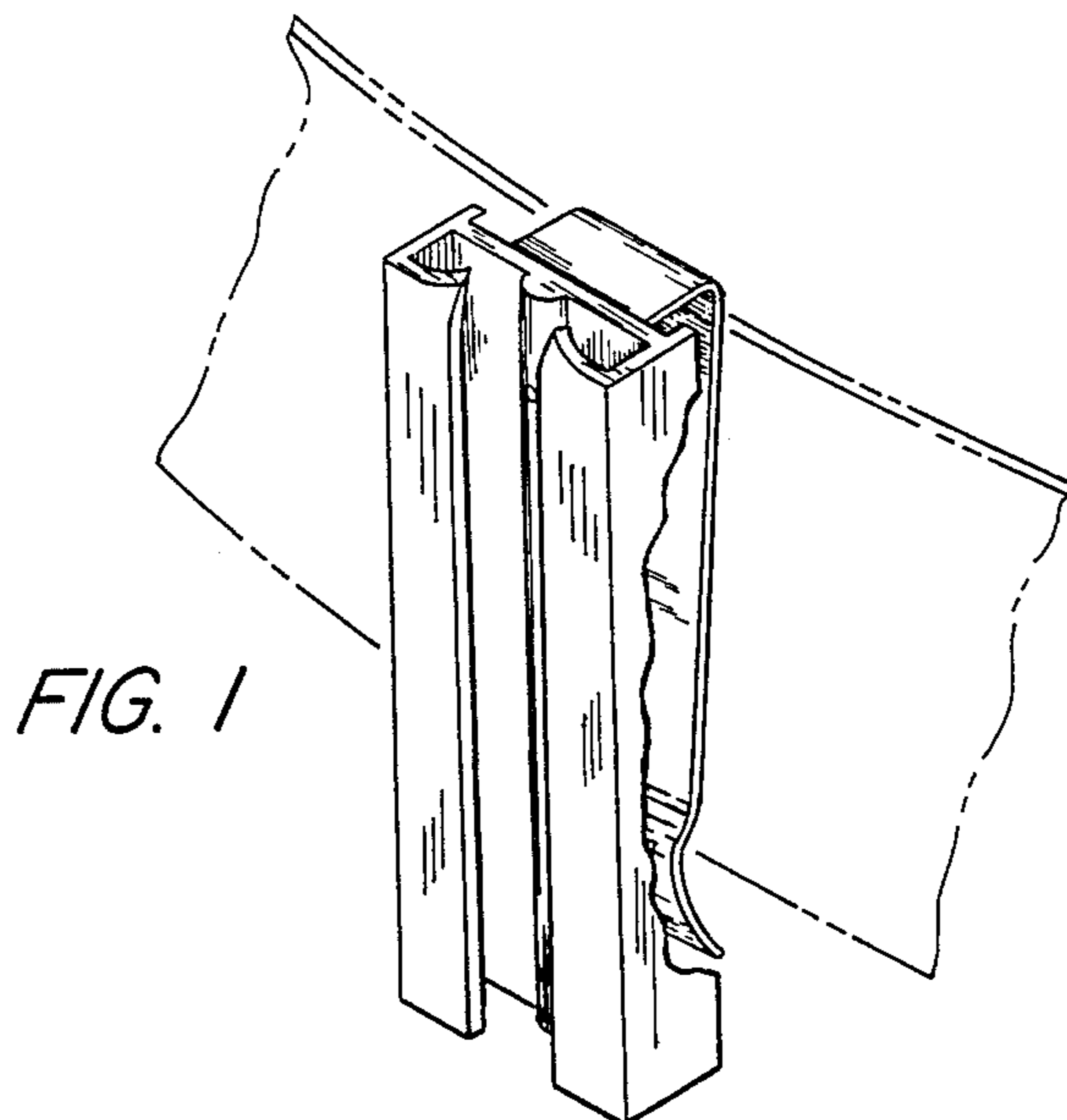

FIG. 7

