

[54] **INTERNAL COMBUSTION ENGINE**

D. 294,832 3/1988 Iton et al. D15/1

[75] **Inventor: Teruo Nakagawa, Osaka, Japan**

OTHER PUBLICATIONS

[73] **Assignee: Kubota Ltd., Osaka, Japan**

Implement & Tractor, 2/21/79, p. 37, Kawasaki Engine Advertisement.

[**] **Term: 14 Years**

Primary Examiner—Wallace R. Burke
Assistant Examiner—Brian N. Vinson
Attorney, Agent, or Firm—Lowe, Price, Leblanc, Becker & Shur

[21] **Appl. No.: 261,026**

[22] **Filed: Oct. 20, 1988**

[30] **Foreign Application Priority Data**

[57] **CLAIM**

Jul. 5, 1988 [JP] Japan 63-26987

The ornamental design for an internal combustion engine, as shown and described.

[52] **U.S. Cl. D15/1**

[58] **Field of Search** D15/1, 3; 123/22, 50 R, 123/50 A, 50 B, 51 R, 51 A, 51 B, 52 R, 56 R, 56 A, 56 B, 65 R, 311

DESCRIPTION

FIG. 1 is a top, front, and left side perspective view of an internal combustion engine showing my new design; FIG. 2 is a front elevational view thereof; FIG. 3 is a rear elevational view thereof; FIG. 4 is a top plan view thereof; FIG. 5 is a bottom plan view thereof; FIG. 6 is a left side elevational view thereof; and FIG. 7 is a right side elevational view thereof.

[56] **References Cited**

U.S. PATENT DOCUMENTS

- D. 239,329 3/1976 Schramm D15/1
- D. 247,177 2/1978 Stevens D15/1
- D. 282,071 1/1986 Nakamura D15/1

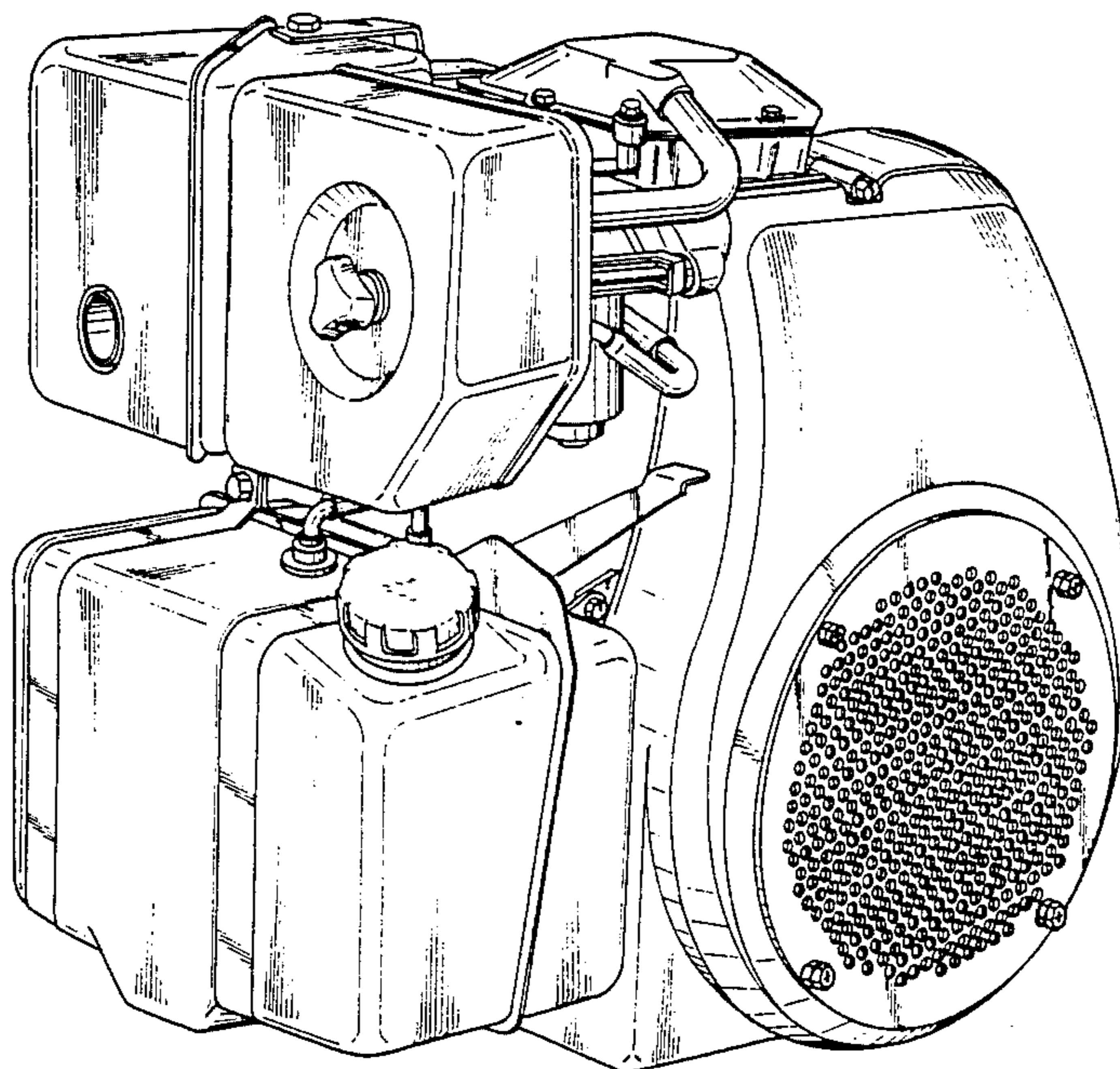

Fig. 1

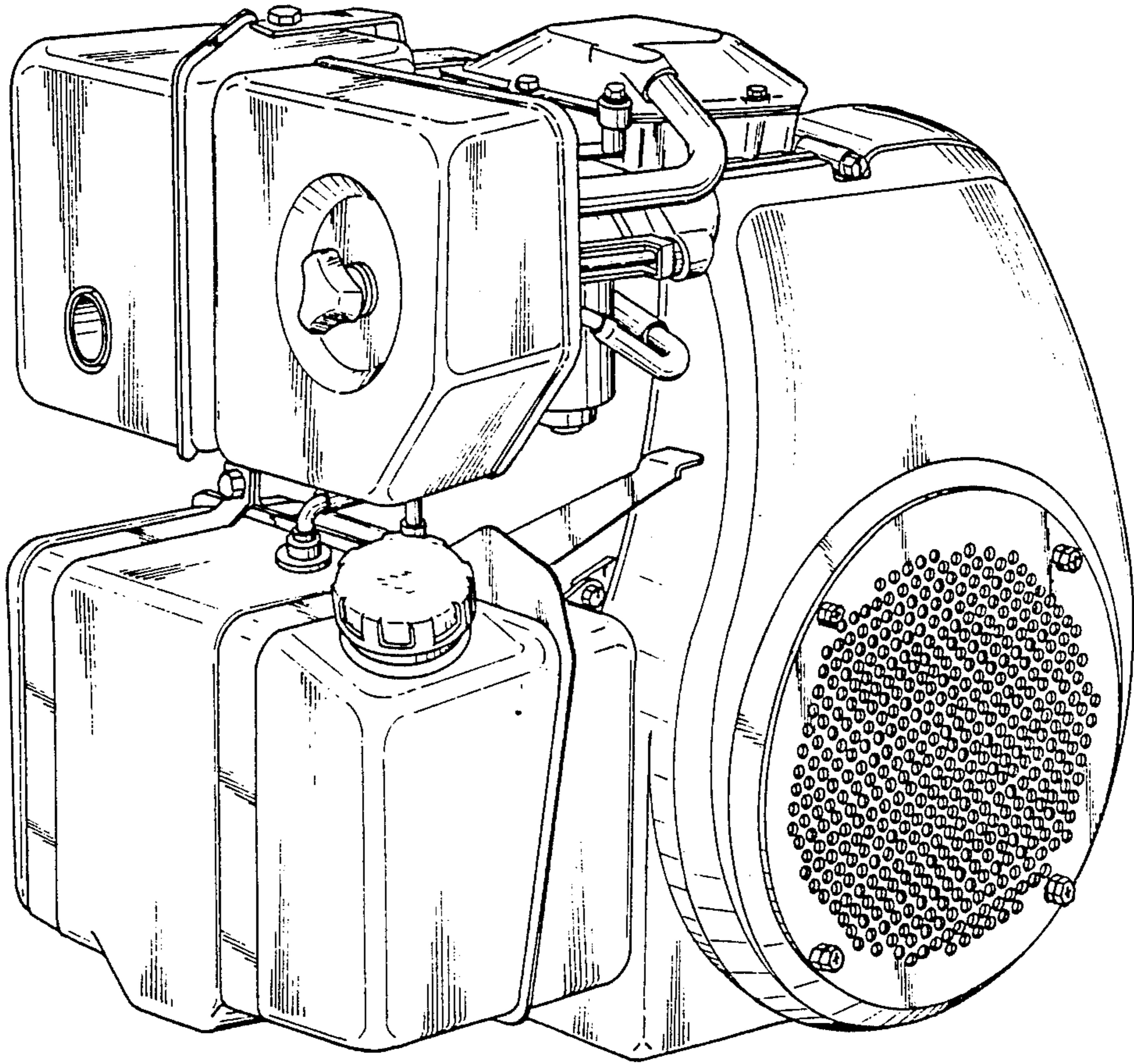

Fig. 2

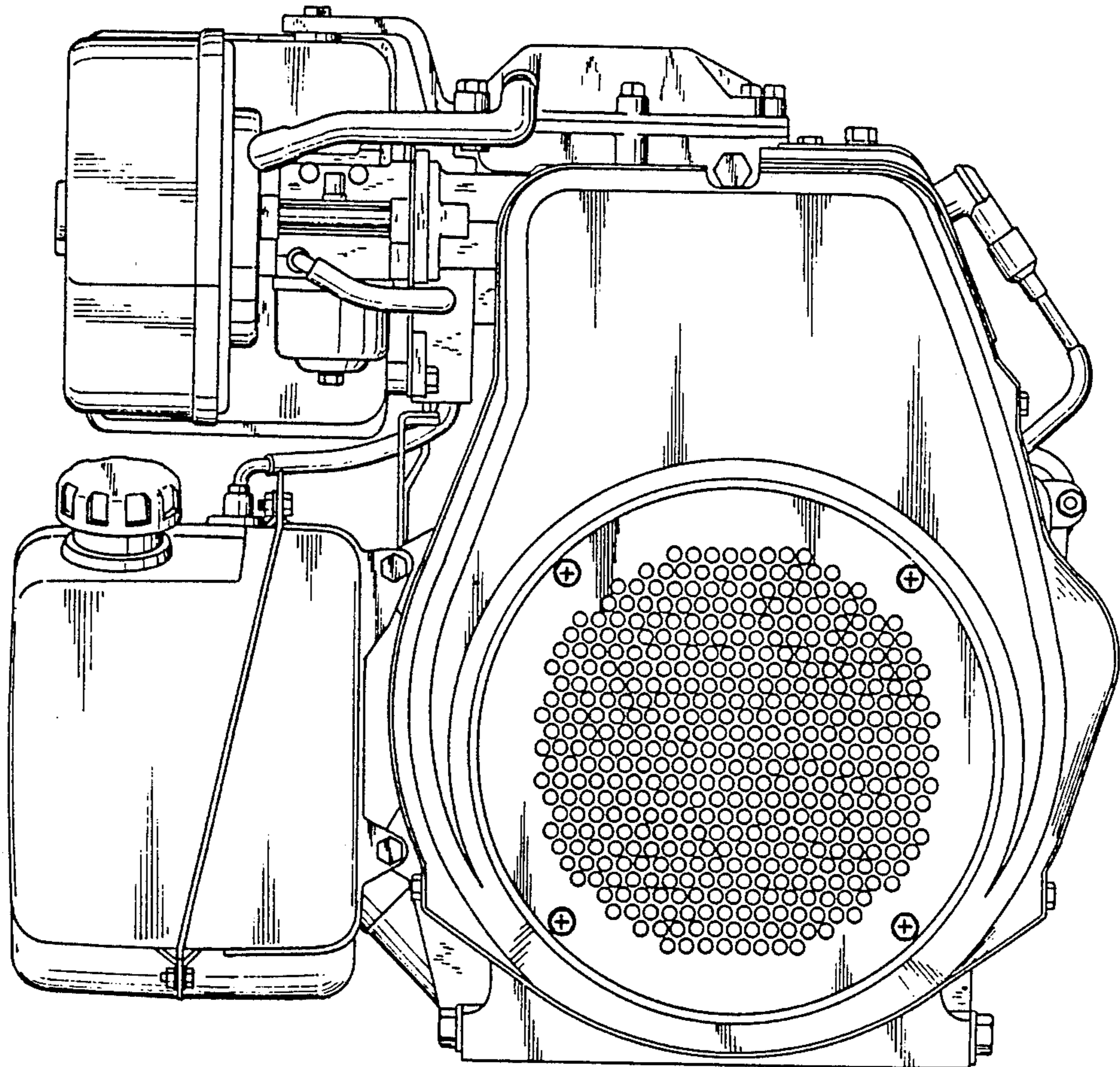

Fig. 3

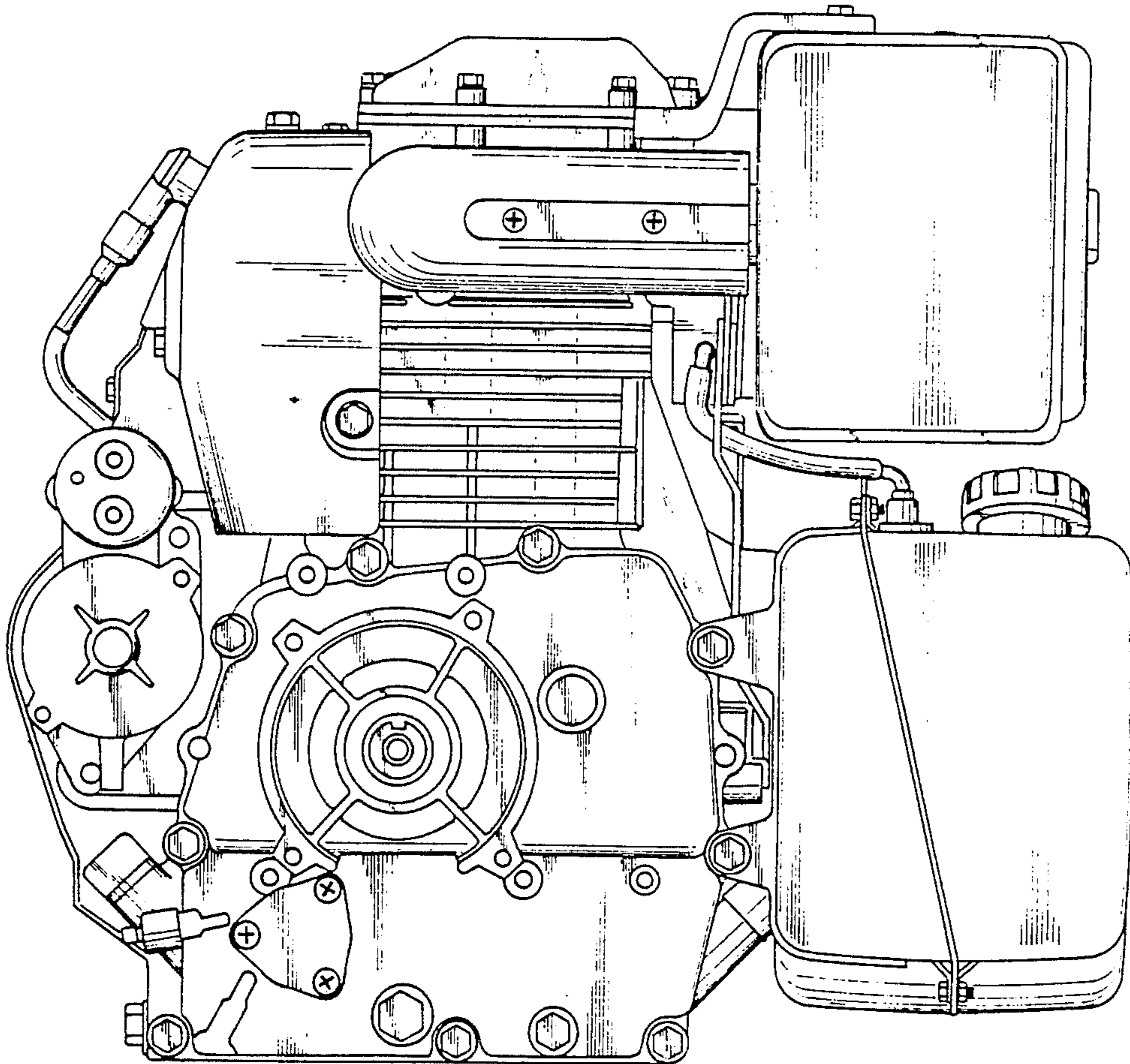

Fig. 4

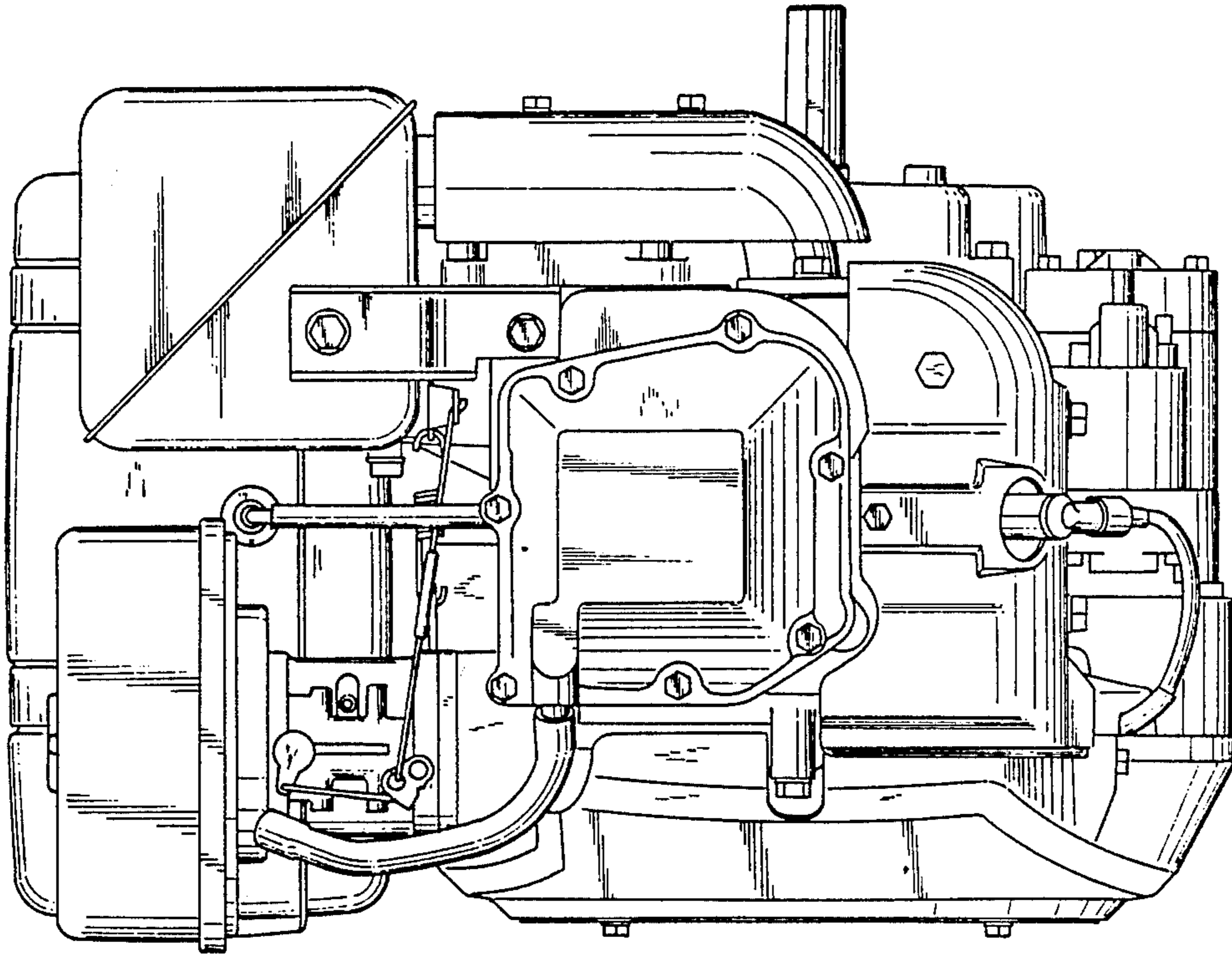

Fig.5

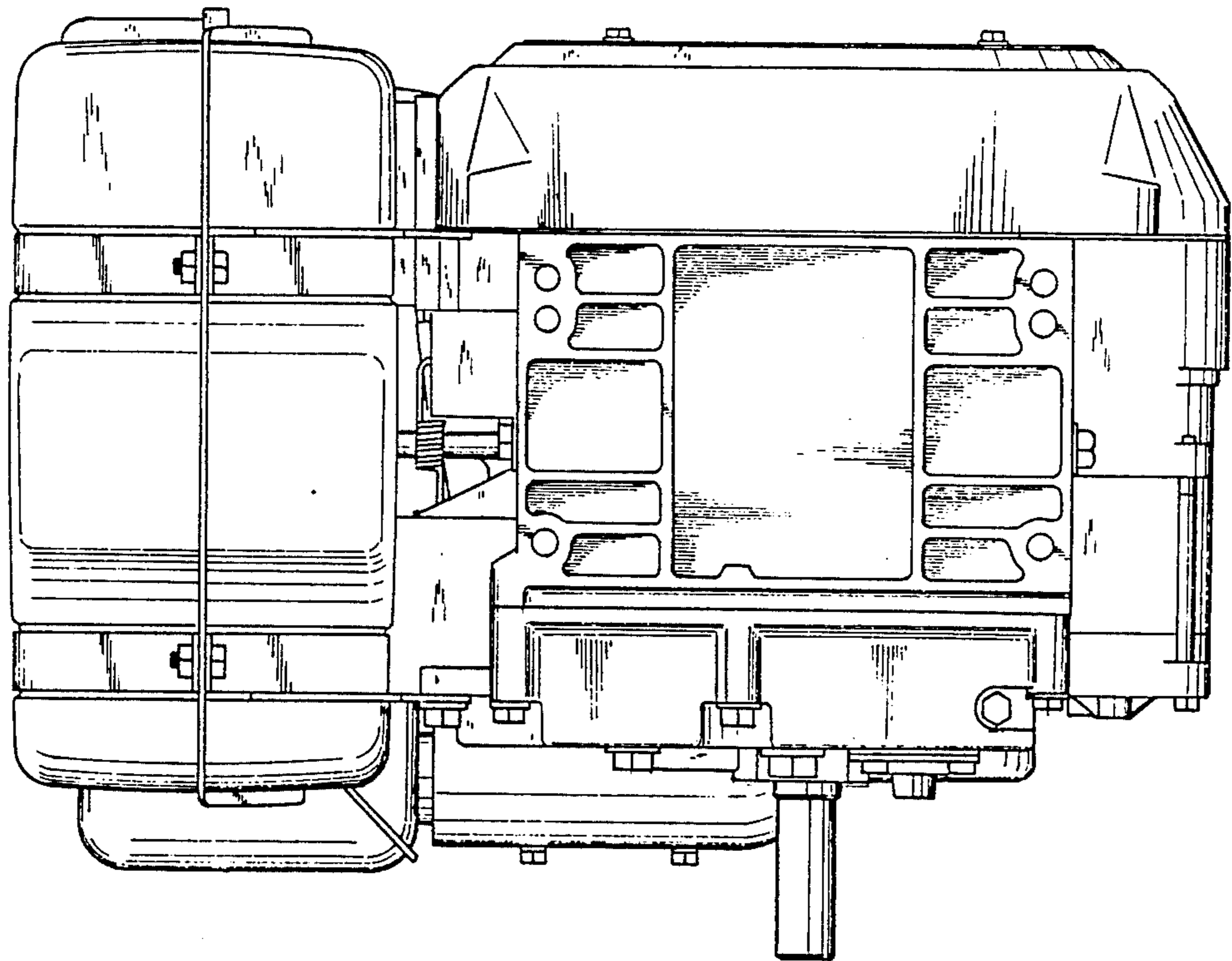

Fig. 6

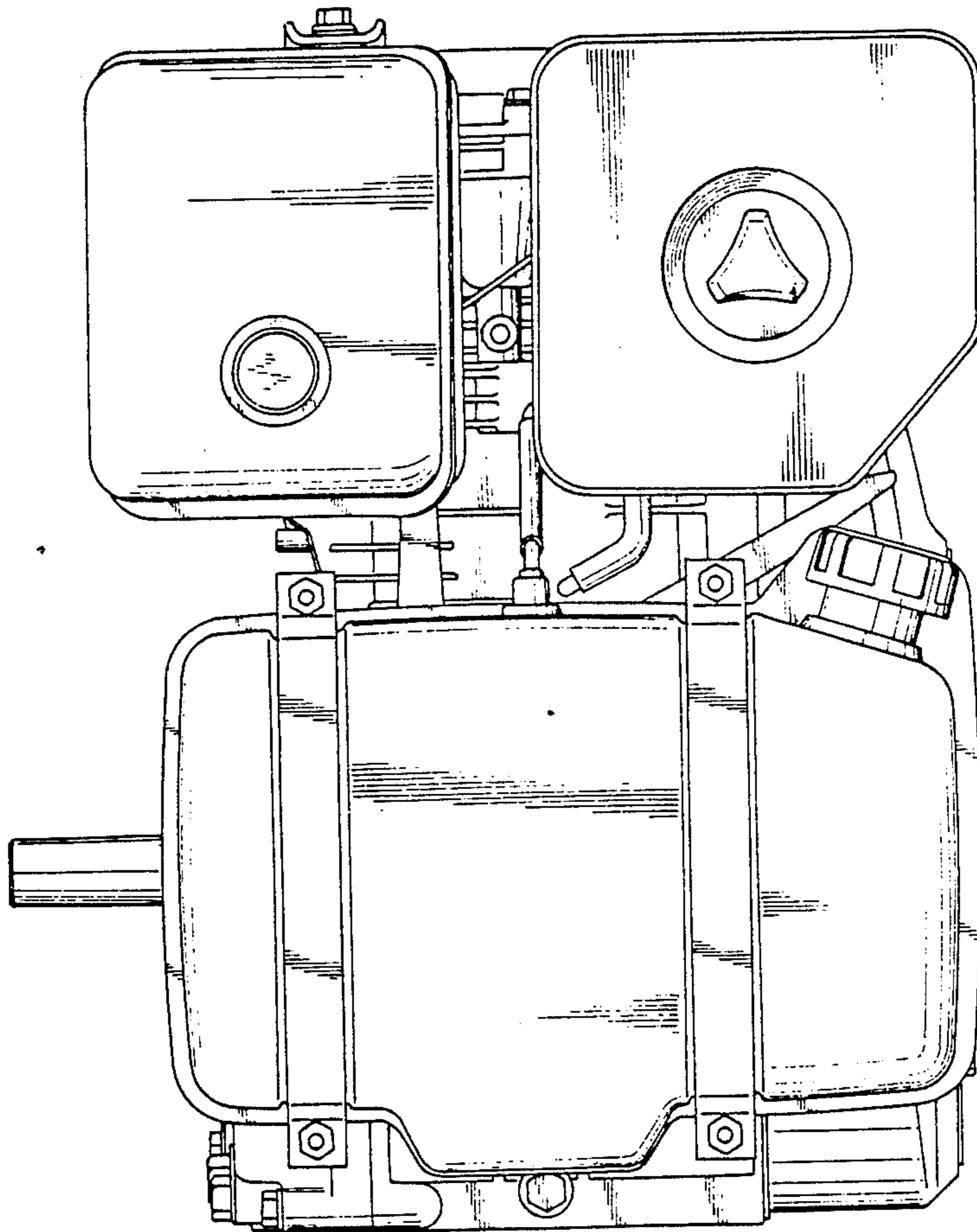

Fig. 7

