

[54] ENGINE

[75] Inventors: Gordon D. Kelly, Elm Grove, Wis.;  
Ronald J. Hoffman, Phoenix, Ariz.

[73] Assignee: Kohler Co., Kohler, Wis.

[\*\*] Term: 14 Years

[21] Appl. No.: 420,234

[22] Filed: Oct. 12, 1989

Related U.S. Application Data

[62] Division of Ser. No. 222,683, Jul. 21, 1988.

[52] U.S. Cl. .... D15/1

[58] Field of Search ..... D15/1, 3, 5; 123/56 B,  
123/56 BC, 56 BA, 41.66-41.67, 41.7, 195 C,  
195 E

[56] References Cited

U.S. PATENT DOCUMENTS

D. 247,177	2/1978	Stevens	.....	D15/1
D. 257,844	1/1981	Stevens	.....	D15/1
D. 276,515	11/1984	Yaguchi	.....	D13/1
D. 281,492	11/1985	Yaguchi	.....	D13/2
D. 282,071	1/1986	Nakamura	.....	D15/1
D. 284,862	7/1986	Iida	.....	D15/1

OTHER PUBLICATIONS

Page 1 of a 1985 Kohler Co., brochure showing three "Magnum" engines.

Page 3 of a 1982 Kohler Co. brochure showing five K and KT series engines.

Page 14 of 1987, Kohler Co. brochure showing another "Magnum" engine.

Page 1 of a 1987 Kohler Co., brochure showing the "Command", 12.5HP engine.

A page showing the Suzuki V120 and V160 engines. Three pages showing Honda's G, GX, and GXV engines.

Two pages of Briggs advertisements showing 8HP and 12.5HP, "Vanguard" engines.

Primary Examiner—Wallace R. Burke

Assistant Examiner—Brian N. Vinson

Attorney, Agent, or Firm—Quarles & Brady

[57] CLAIM

The ornamental design for an engine, as shown and described.

DESCRIPTION

FIG. 1 is a perspective view taken from the top, front and right side of an engine showing our new design; FIG. 2 is a front elevational view thereof; FIG. 3 is a right side elevational view thereof; FIG. 4 is a left side elevational view thereof; FIG. 5 is a top plan view thereof; FIG. 6 is a rear elevational view thereof; FIG. 7 is a bottom plan view thereof; FIG. 8 is a front elevational view of a second embodiment thereof, the only difference being that it is a mirror reversal of the first embodiment. The fragmentary broken-line representations of pull handles and auxiliary power takeoffs in the views are for illustrative purposes only and form no part of the claimed design.

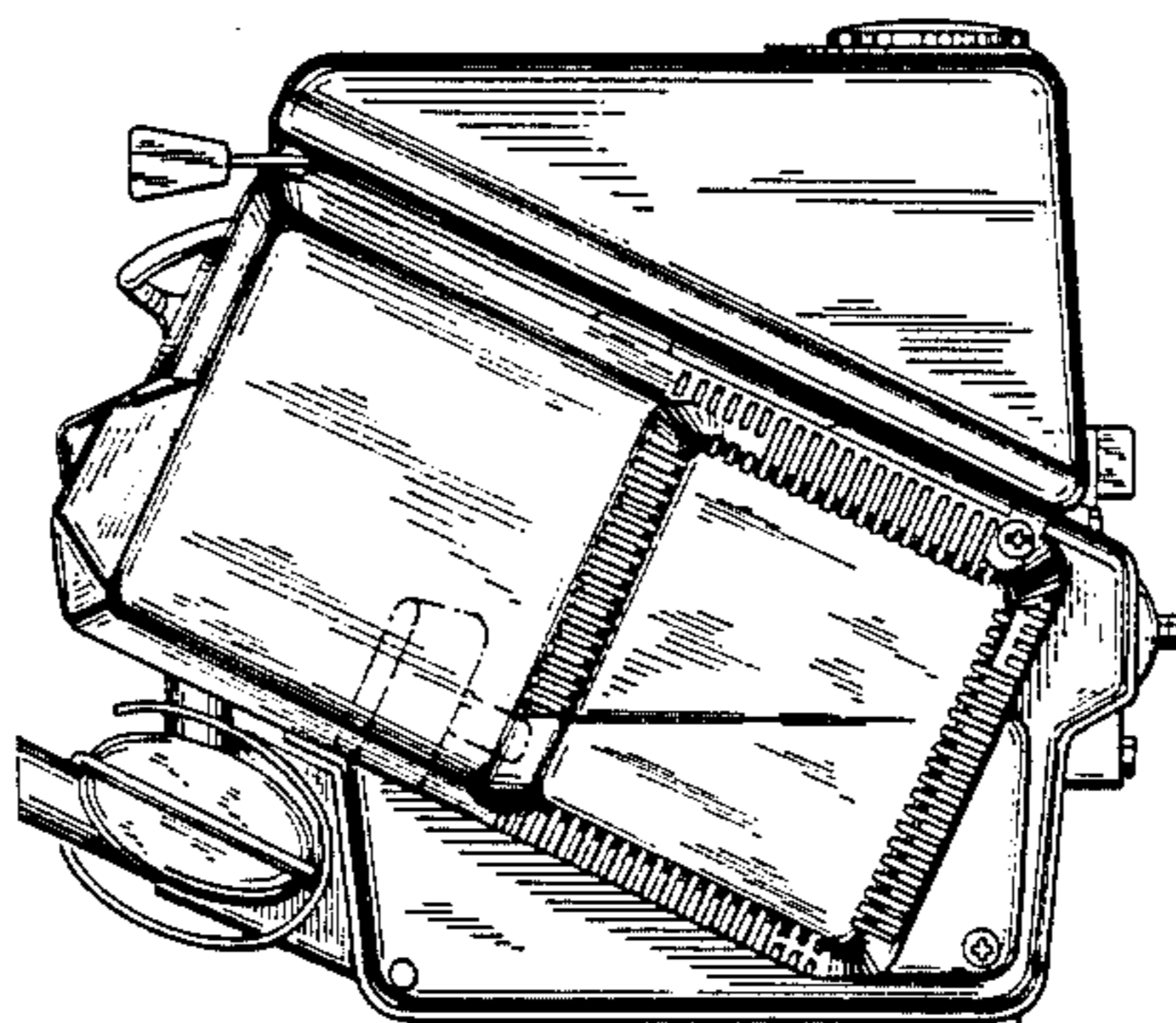
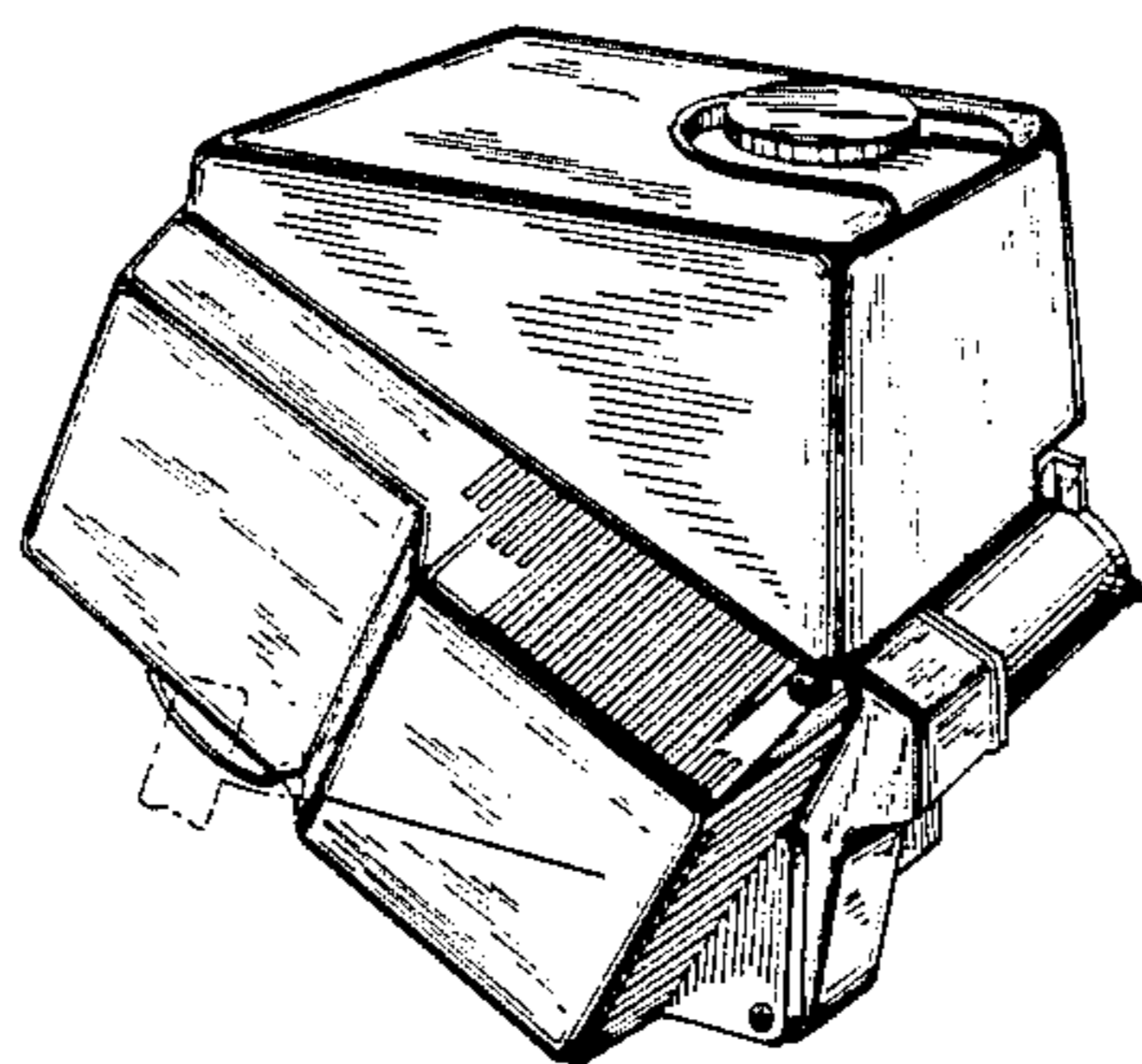

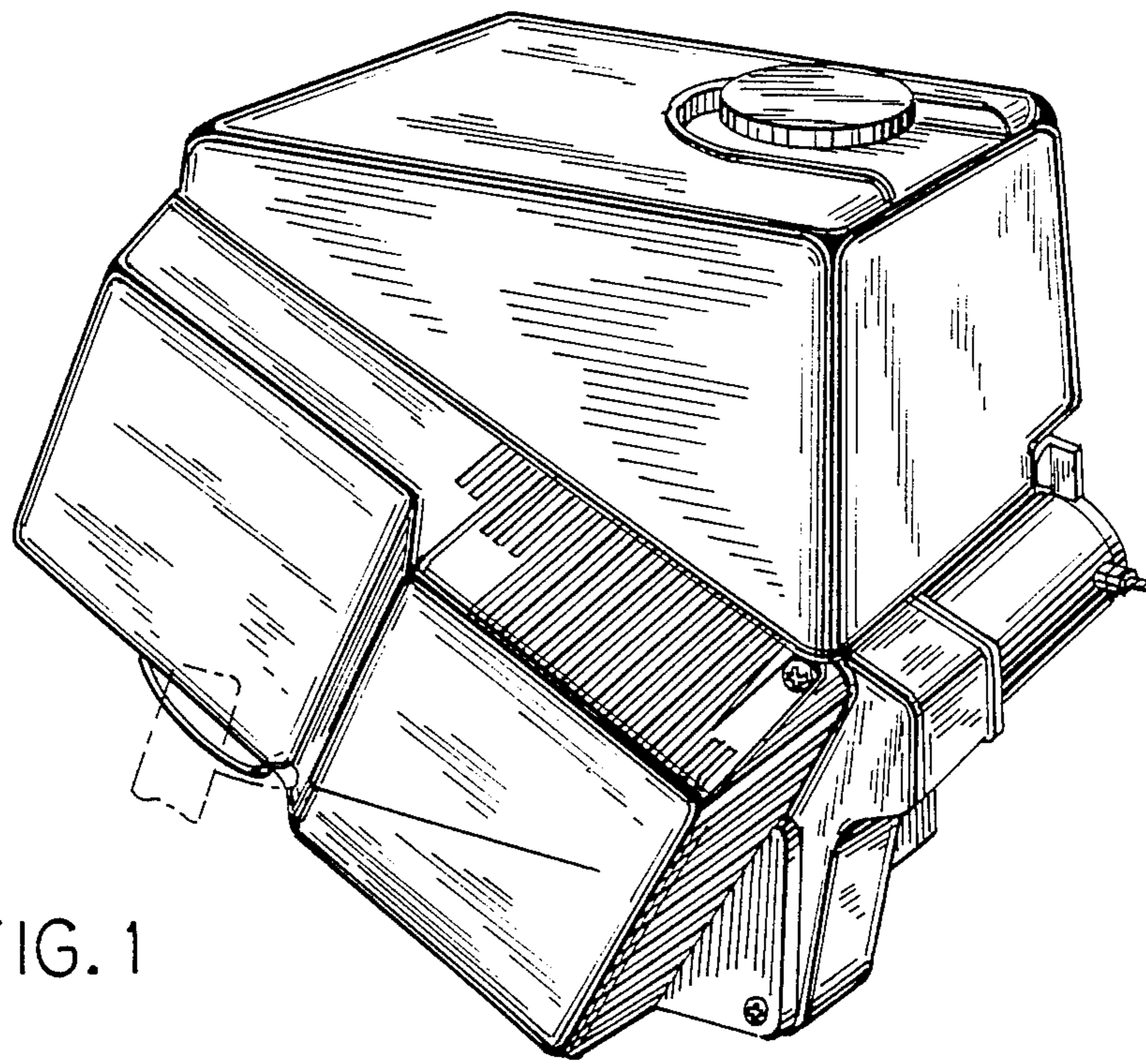

FIG. 1

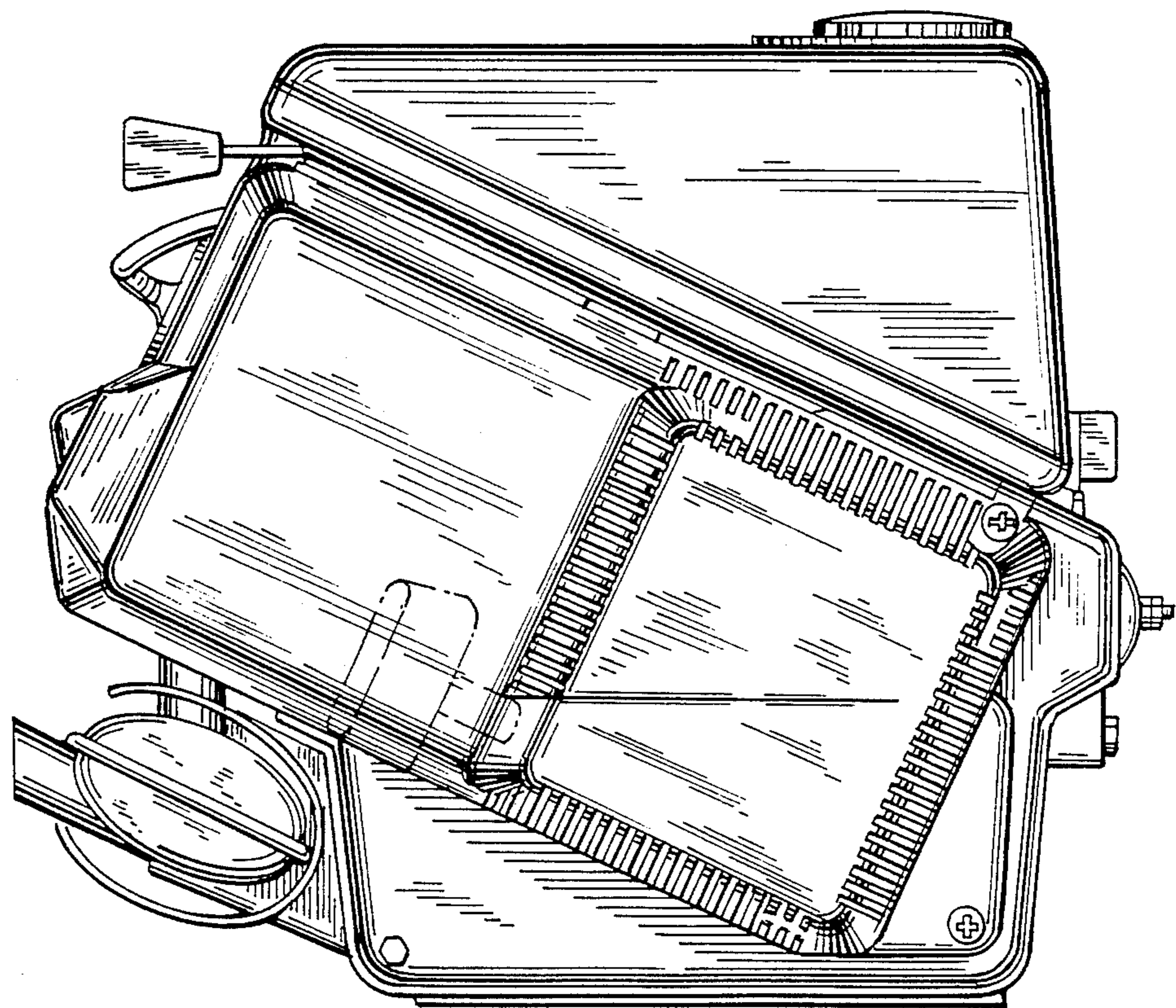

FIG. 2

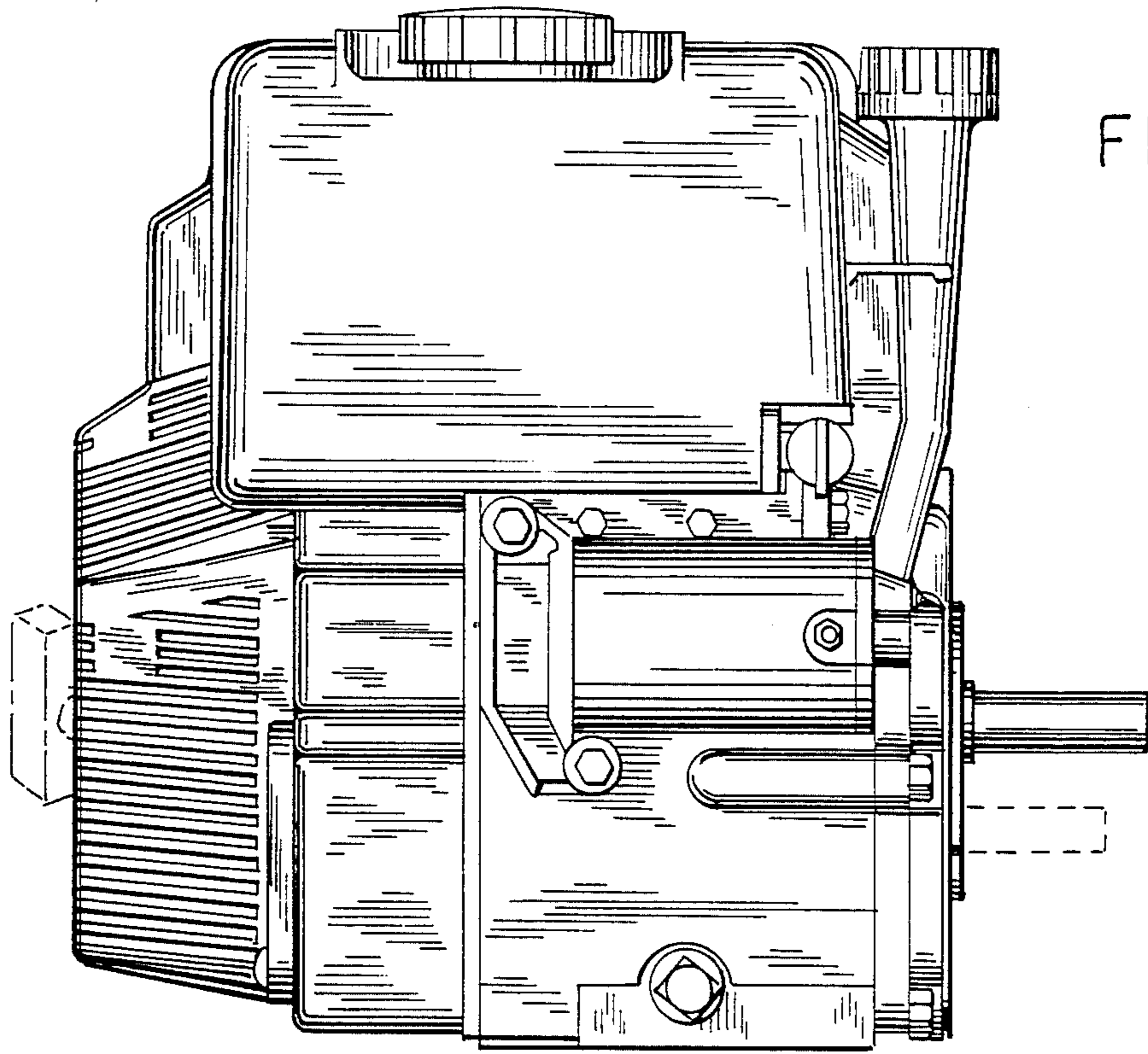

FIG. 3

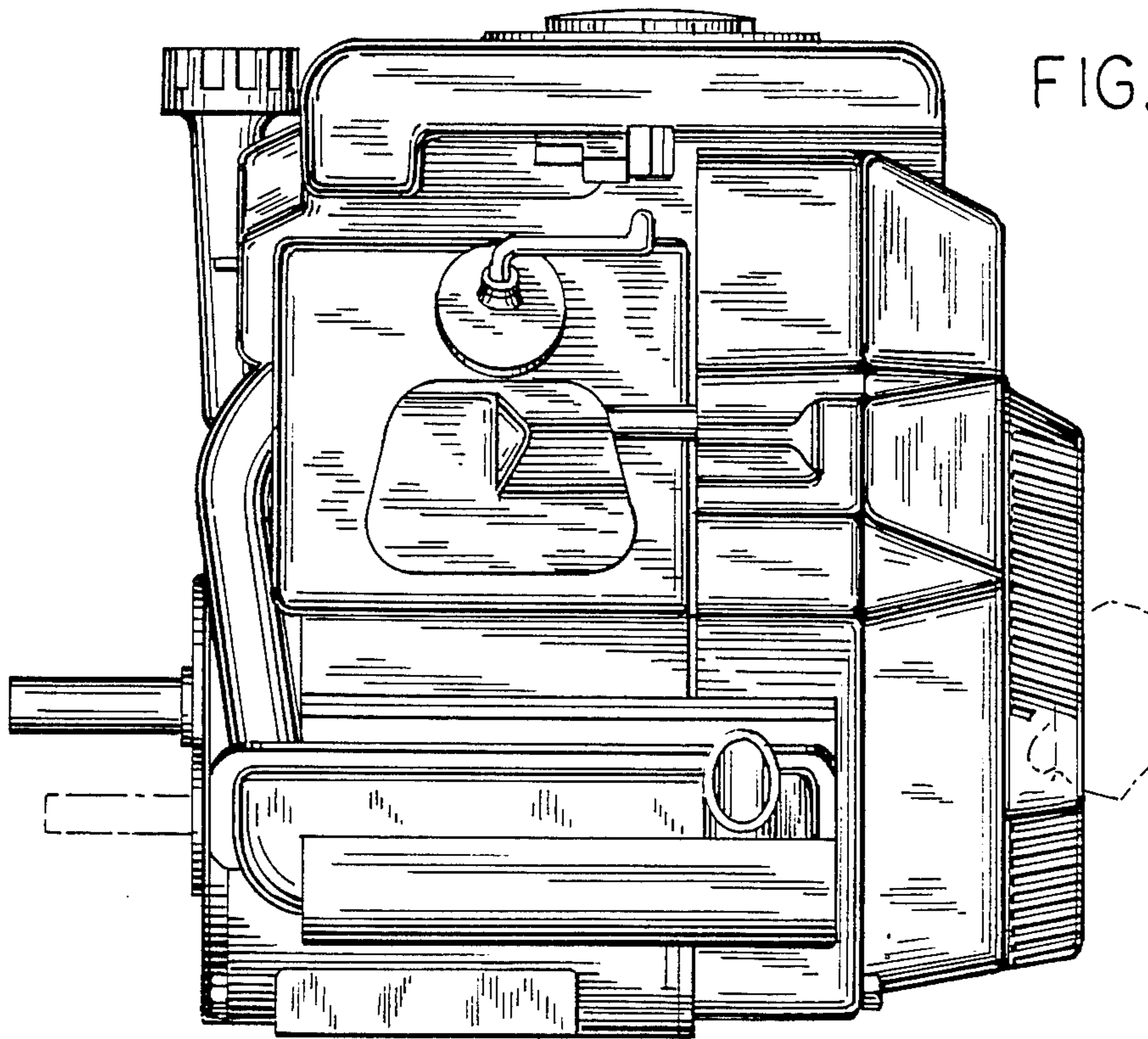

FIG. 4

FIG. 5

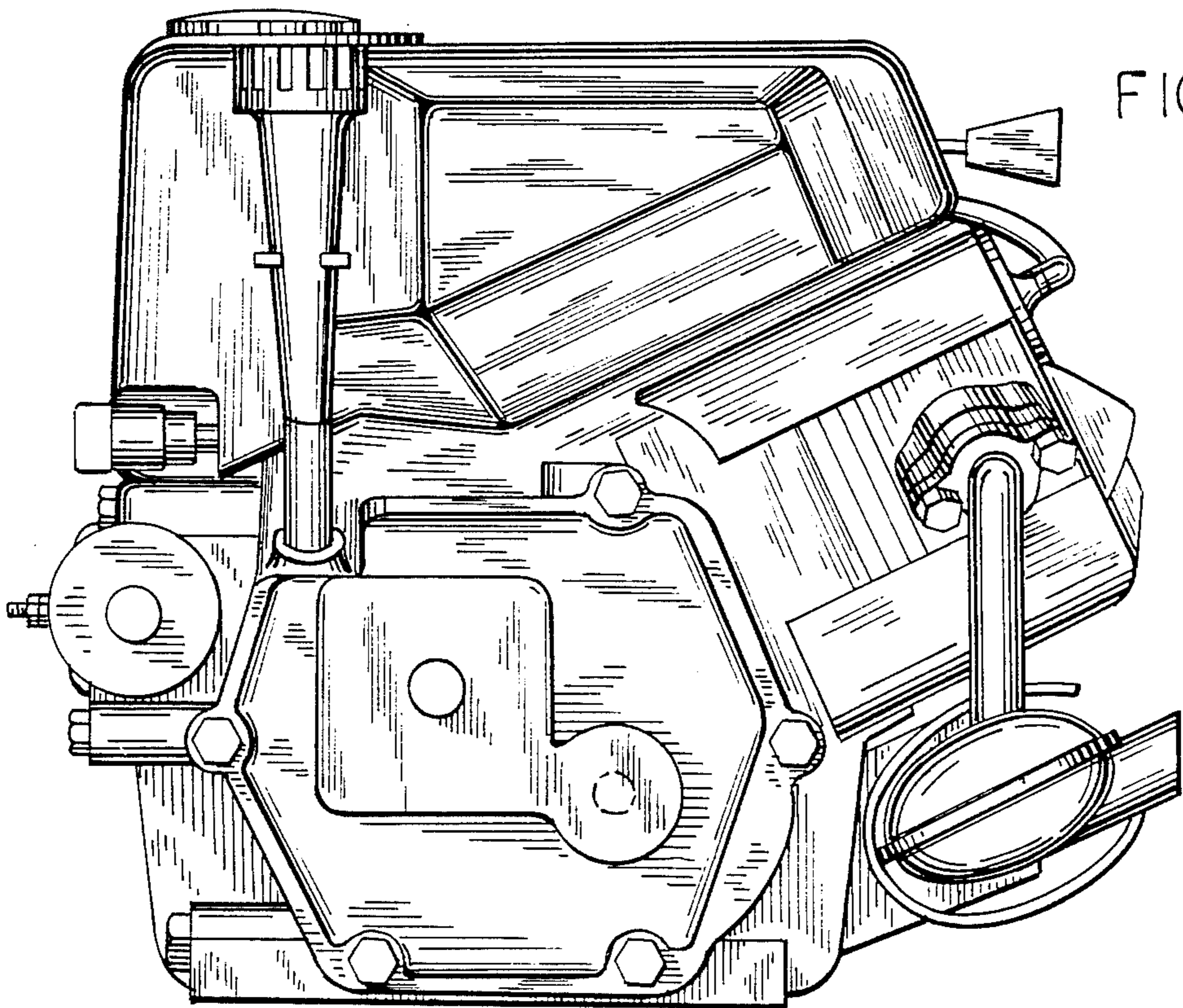
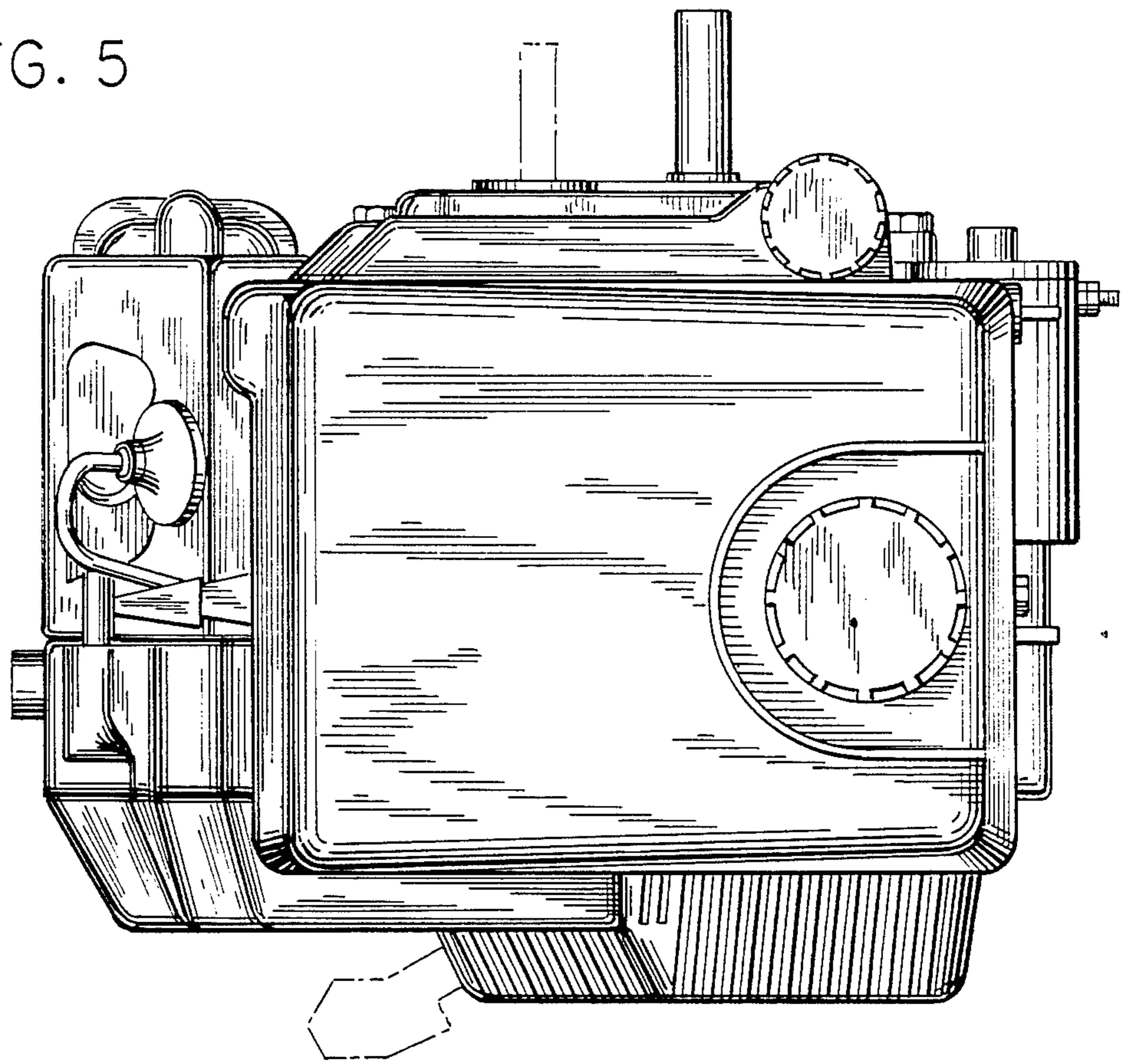

FIG. 6

FIG. 7

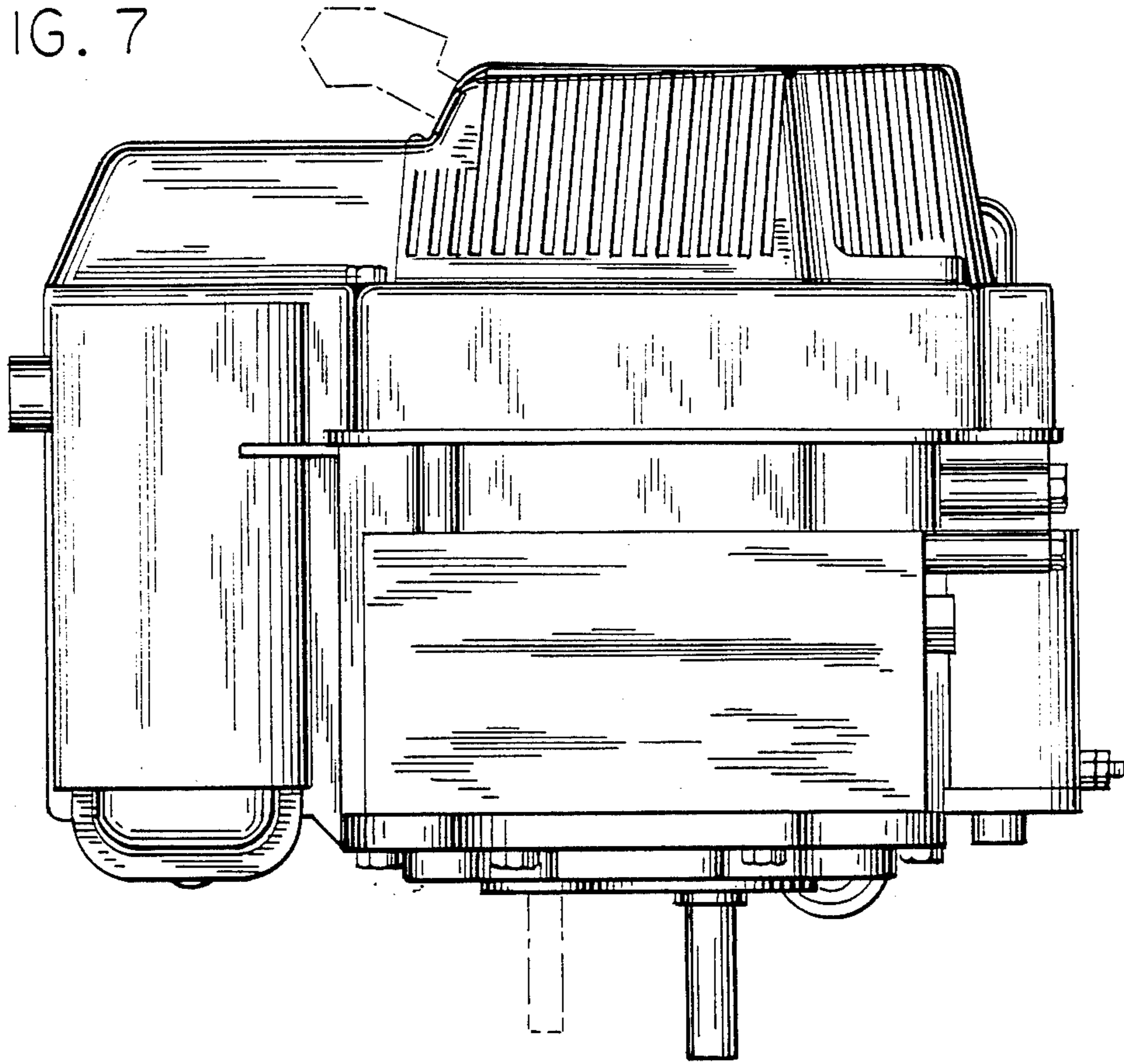

FIG. 8

