

[54] **VEHICLE TIRE**

[75] **Inventors: Romano Guermandi, Milan; Maurizio Boiocchi, Segrate, both of Italy**

[73] **Assignee: Pirelli Coordinamento Pneumatici S.p.A., Italy**

[\*\*] **Term: 14 Years**

[21] **Appl. No.: 110,495**

[22] **Filed: Oct. 20, 1987**

[30] **Foreign Application Priority Data**

May 8, 1987 [IT] Italy ..... 21557/87[U]

[52] **U.S. Cl. .... D12/147**

[58] **Field of Search ..... D12/137, 136, 141-143, D12/145-151; 152/209 R, 209 B, 209 D**

[56] **References Cited**

**U.S. PATENT DOCUMENTS**

- D. 278,423 4/1985 Baus ..... D12/147
- D. 283,609 4/1986 Kawabata et al. .... D12/147

**OTHER PUBLICATIONS**

1987 Tread Design Guide, ©1/87, p. 74, Tayfene R-707 Steel Radial Tire, bottom right side of page.

1987 Tread Design Guide, ©1/87, p. 201, Trison All Steel Radial 942 Tire, second row down from top, right side of page.

187 Tread Design Guide, ©1/87, p. 202, Toyo M-604 Tire, second row down from top, right side of page.

*Primary Examiner*—James M. Gandy

*Attorney, Agent, or Firm*—Stevens, Davis, Miller & Mosher

[57] **CLAIM**

The ornamental design for a vehicle tire, as shown and described.

**DESCRIPTION**

FIG. 1 is a front elevational view of a vehicle tire showing our new design it being understood that the tread pattern is repeated uniformly throughout the circumference of the tire and the opposite side is the same as that shown;

FIG. 2 is a perspective view thereof; and FIG. 3 is a side elevation view thereof.

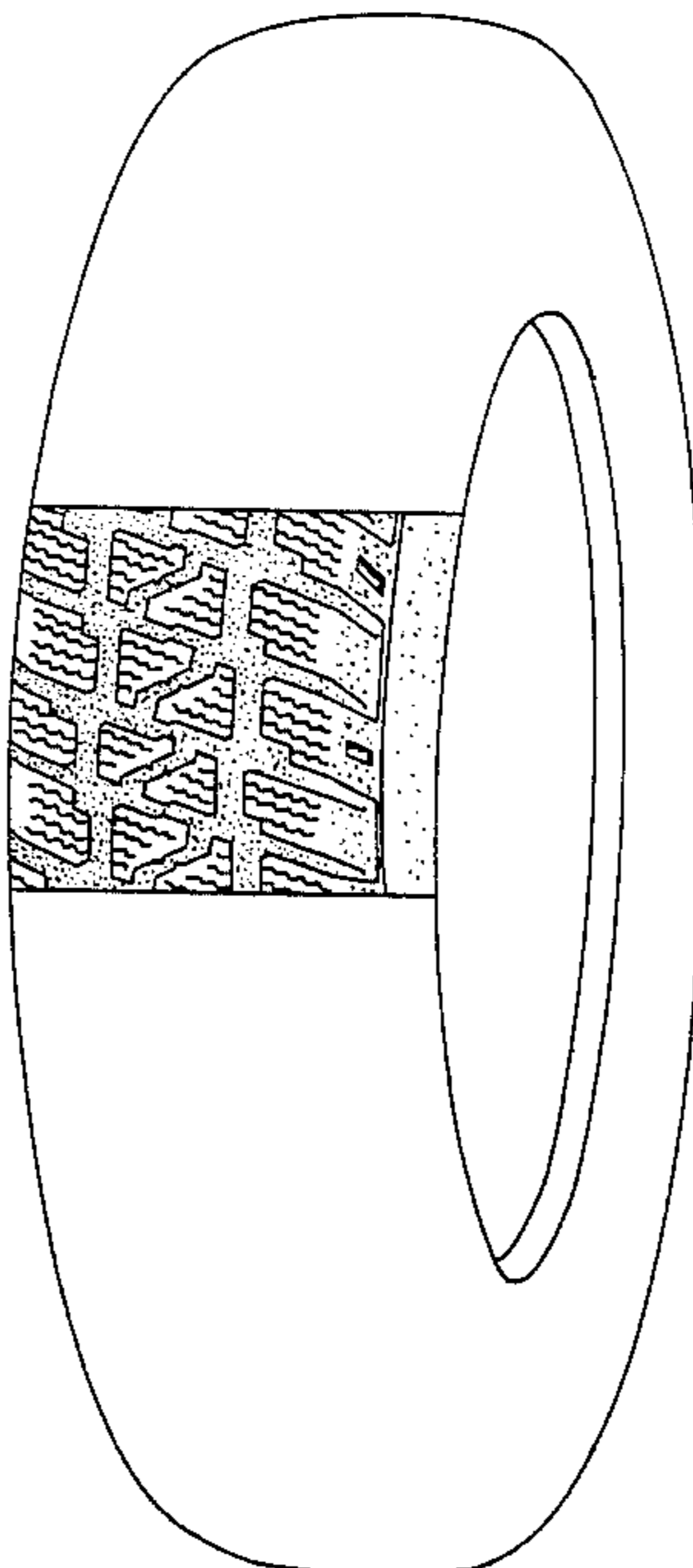

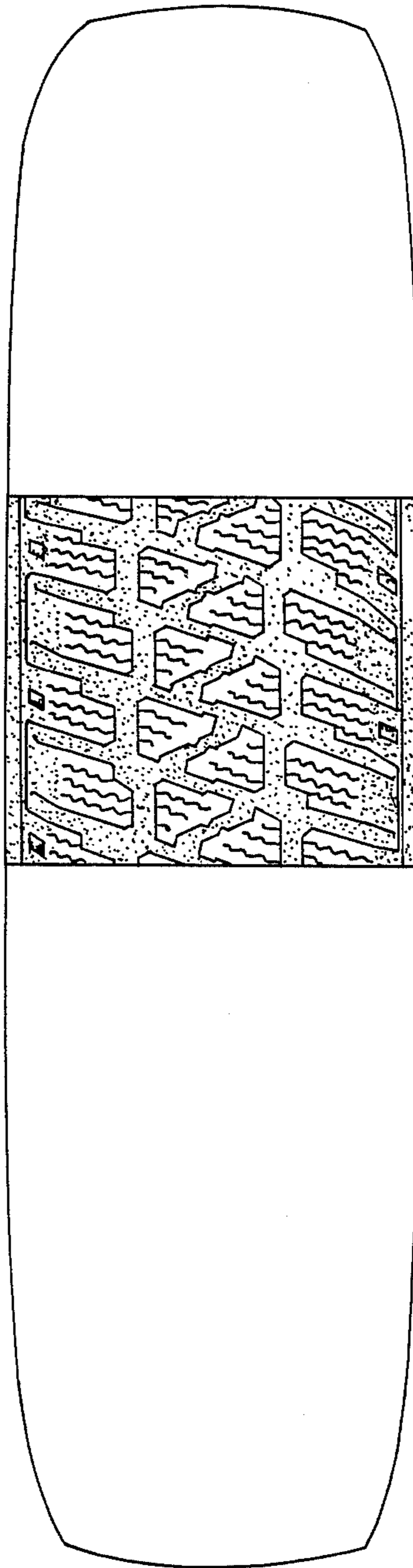

FIG. 1

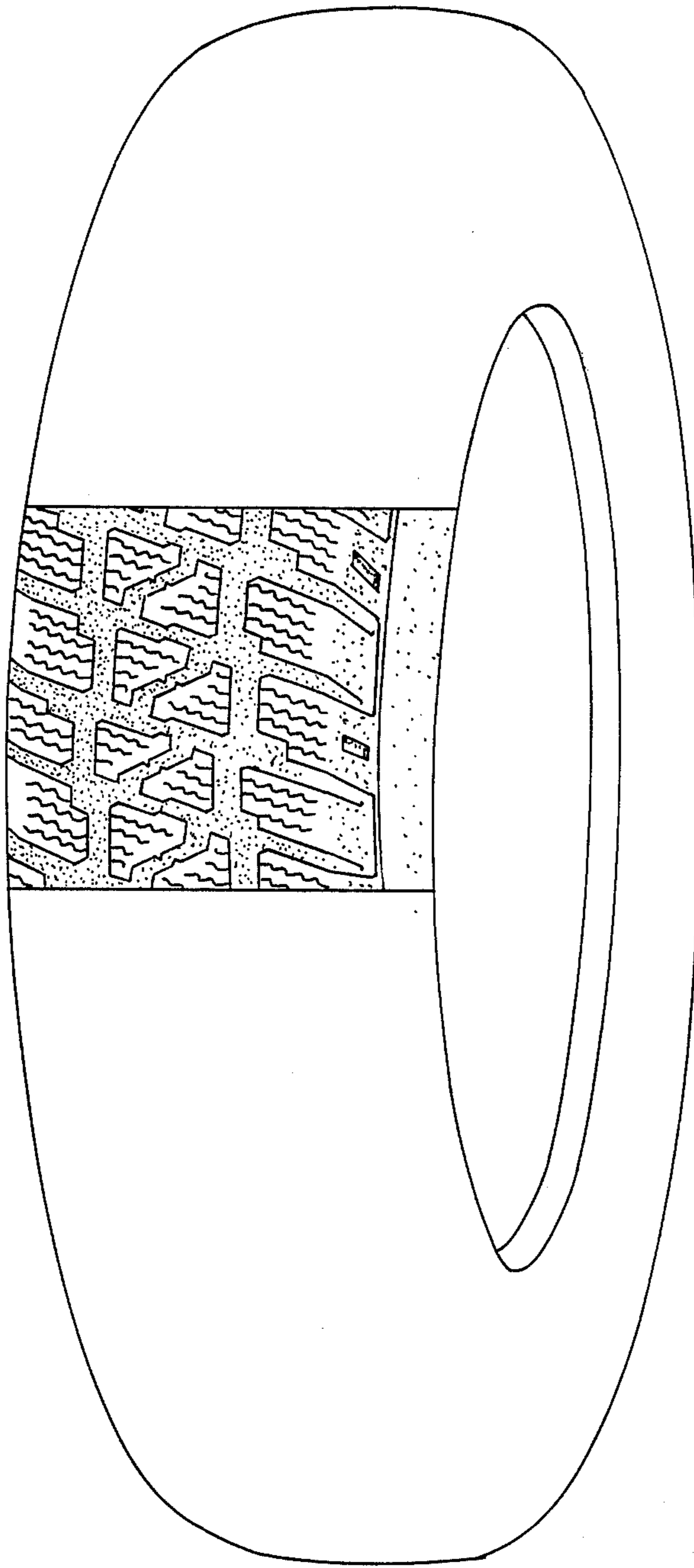

FIG. 2

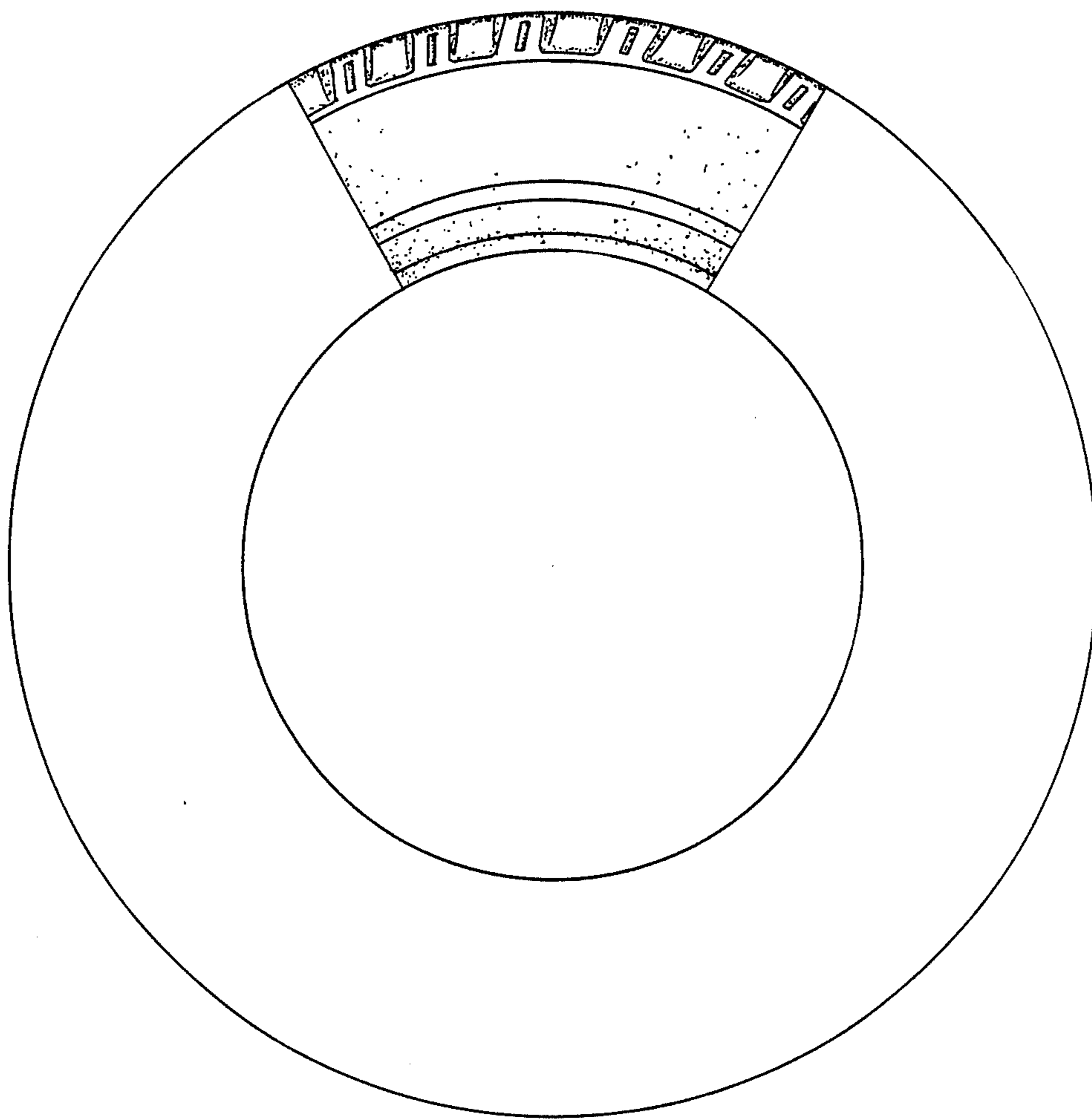

FIG. 3