

[54] COMBINED SYSTEM ANALYZER FOR BRAKES AND LIGHTS

[76] Inventors: Don H. Little; David A. Little, both of 9 Granite St., Methuen, Mass. 01844

[**] Term: 14 Years

[21] Appl. No.: 34,053

[22] Filed: Apr. 2, 1987

[52] U.S. Cl. D10/78

[58] Field of Search D10/75, 77, 78; 73/121, 73/128, 132; 356/213; 324/149, 156

[56] References Cited

U.S. PATENT DOCUMENTS

D. 110,727	8/1938	MacMillan	D10/78	X
D. 186,221	9/1959	Lemmenes	D10/75	
D. 195,260	5/1963	Armbruster	D10/75	
D. 260,085	8/1981	Mitchell	D10/78	
3,690,165	9/1972	Sturmo et al.	73/126	X

4,307,604	12/1981	Domitter	73/121	
4,476,721	10/1984	Hochreuther et al.	324/156	X
4,771,387	9/1988	Hexal et al.	73/121	X
4,824,182	8/1989	Steffes et al.	73/121	X

Primary Examiner—Nelson C. Holtje
Assistant Examiner—Antoine D. Davis
Attorney, Agent, or Firm—Pearson & Pearson

[57] CLAIM

The ornamental design for a combined system analyzer for brakes and lights, as shown and described.

DESCRIPTION

FIG. 1 is a top, front and left side perspective view of a combined system analyzer for brakes and lights showing our new design;
FIG. 2 is a front elevational view;
FIG. 3 is a right side elevational view;
FIG. 4 is a top plan view;
FIG. 5 is a rear elevational view;
FIG. 6 is a left side elevational view; and
FIG. 7 is a bottom plan view thereof.

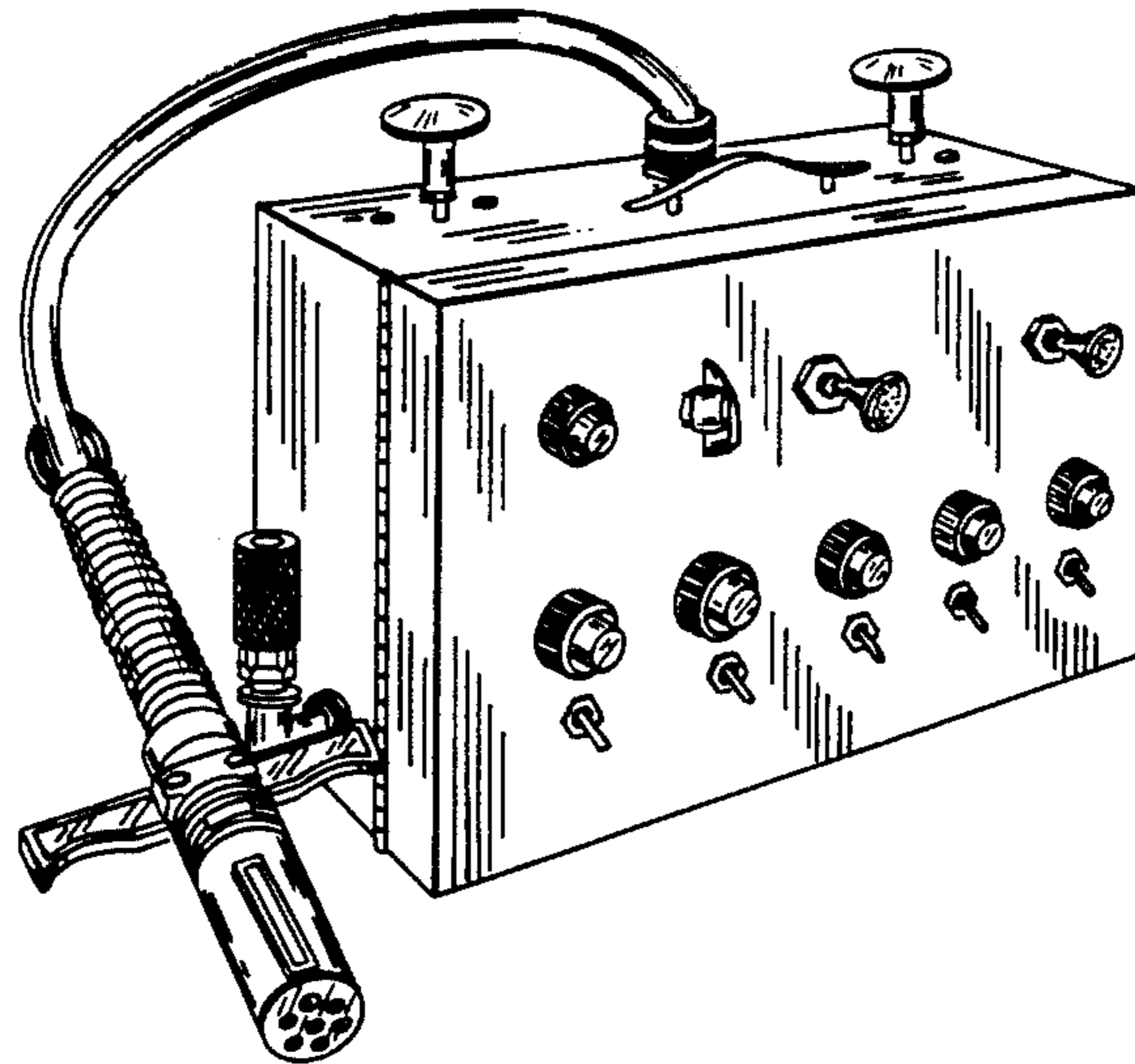

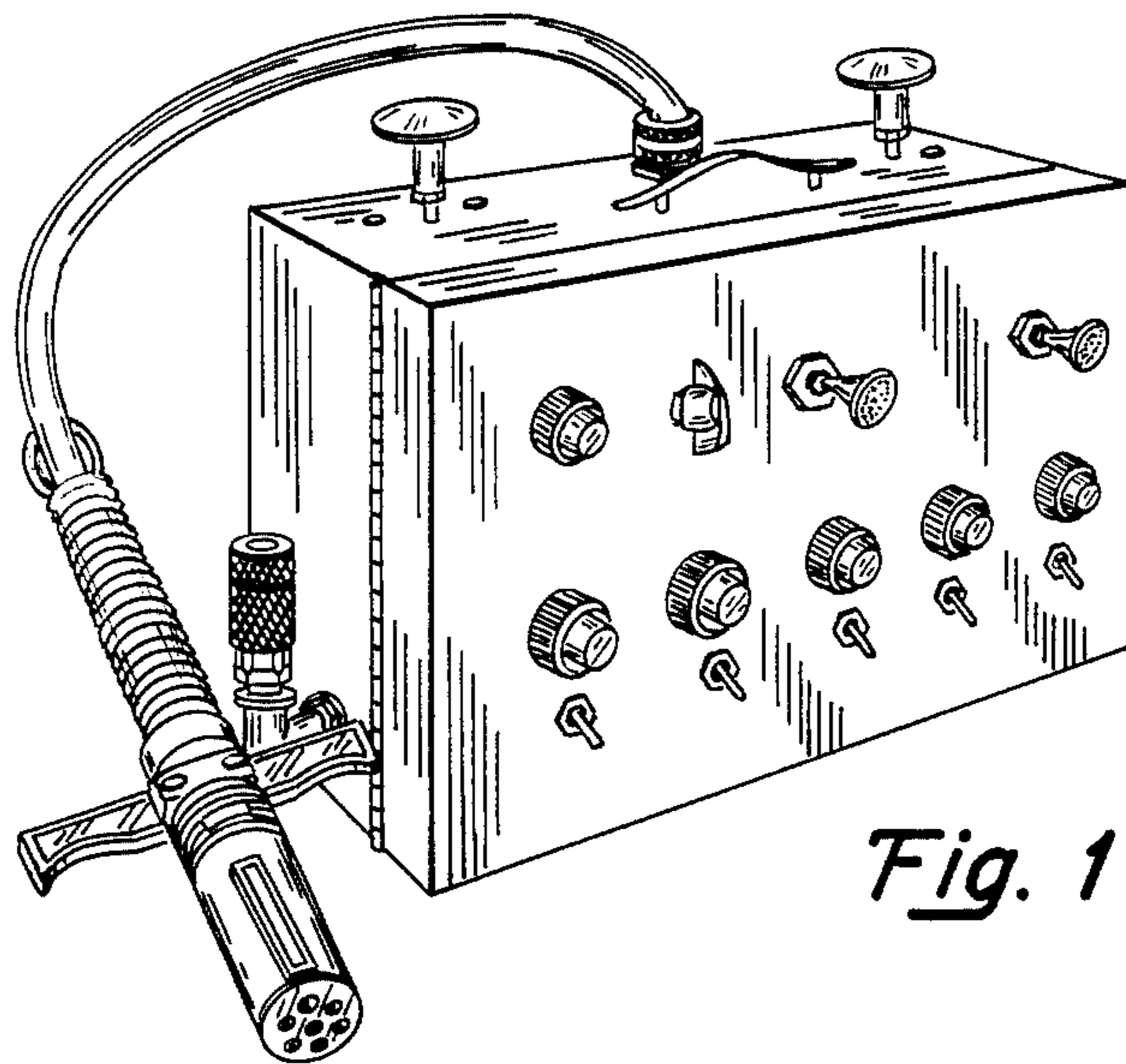

Fig. 1

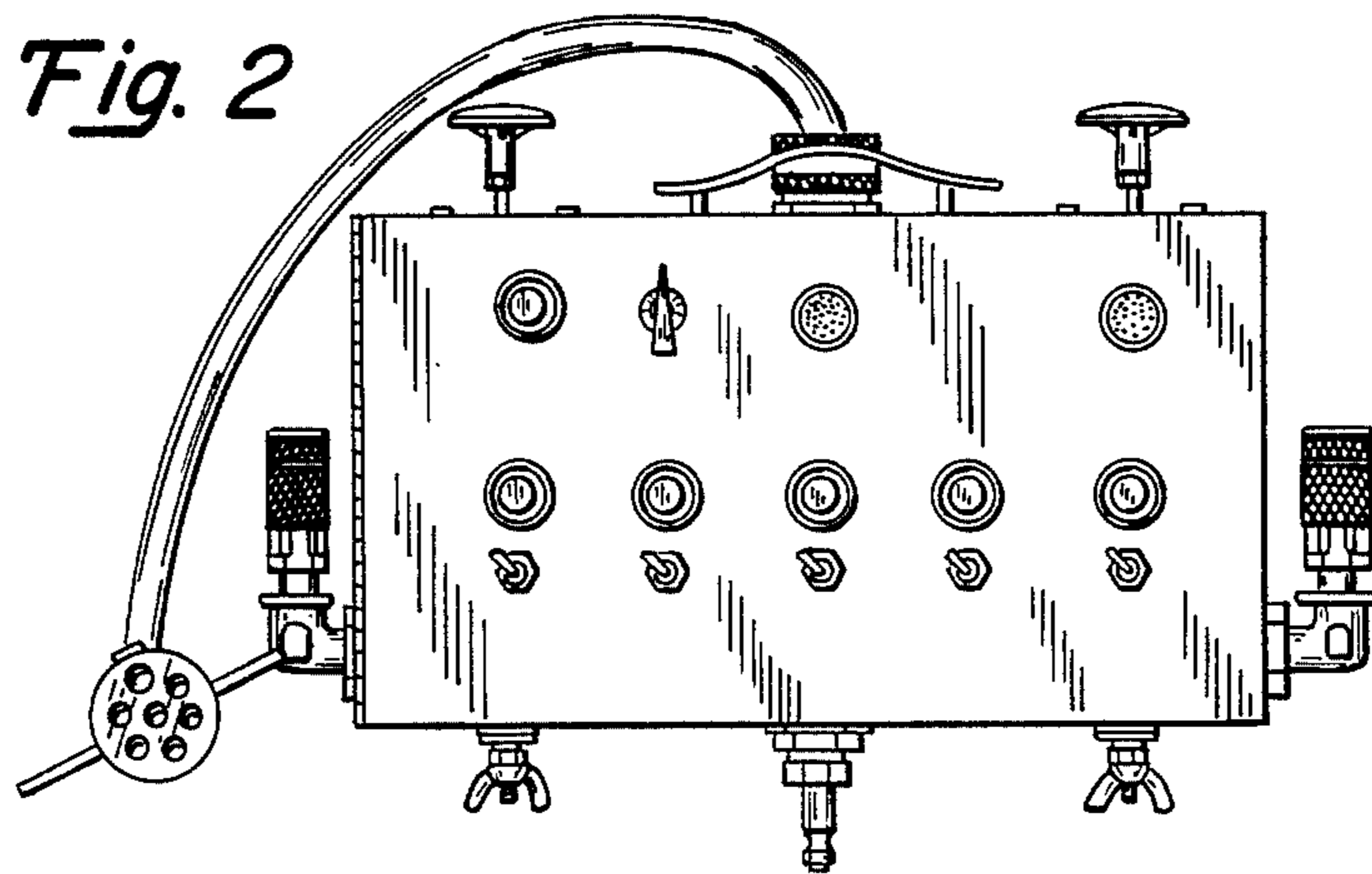

Fig. 2

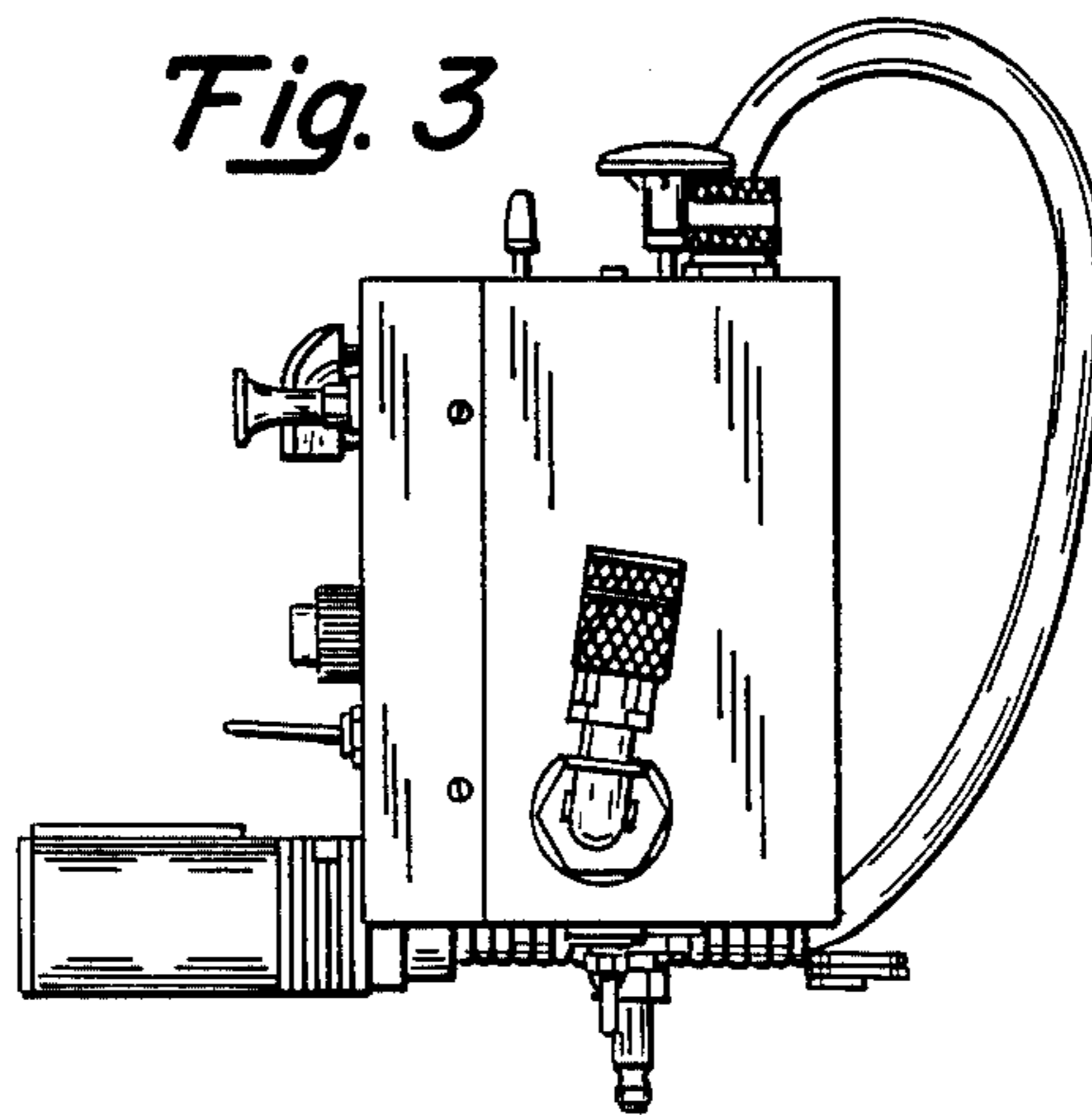

Fig. 3

Fig. 4

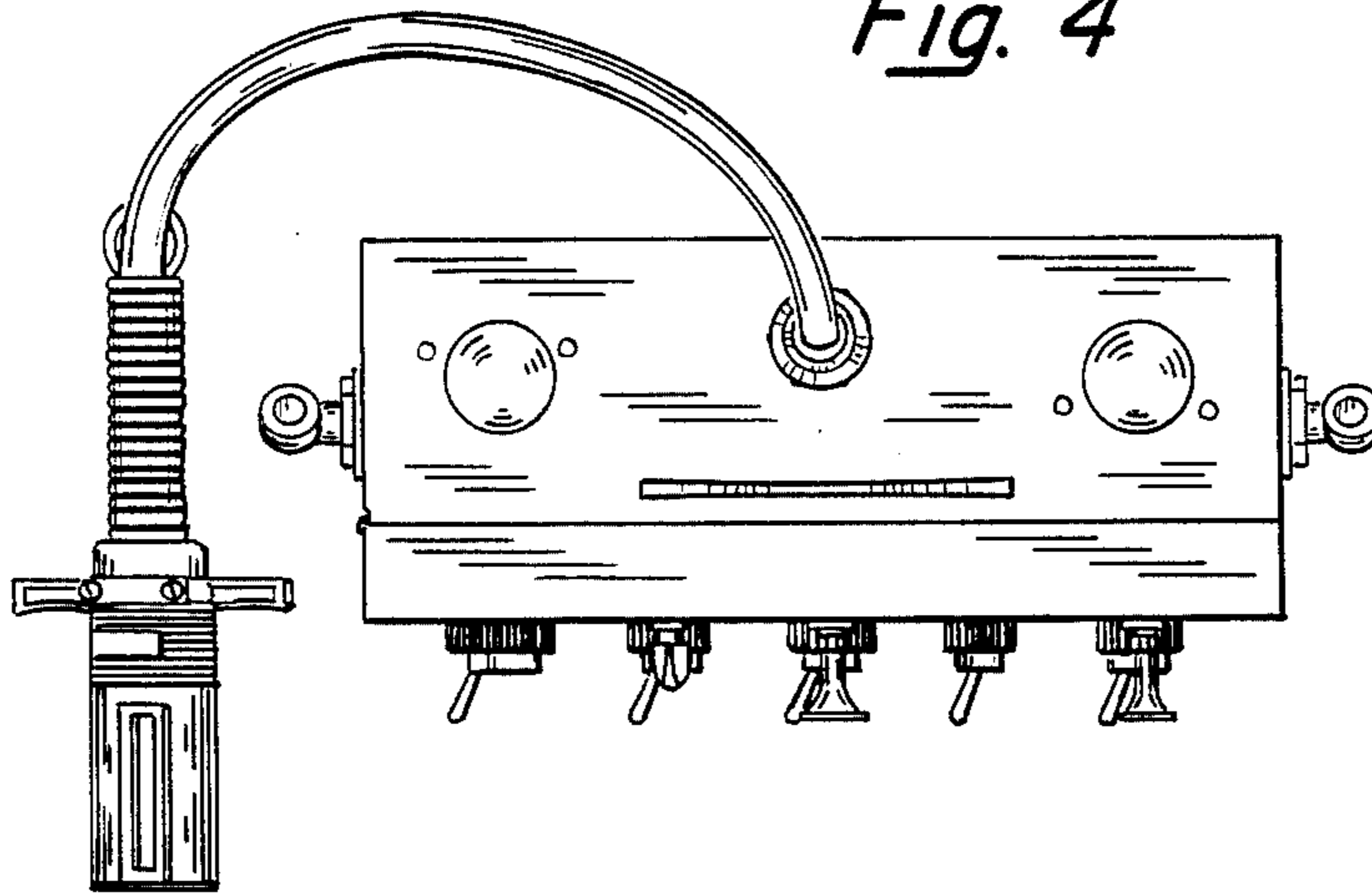

Fig. 5

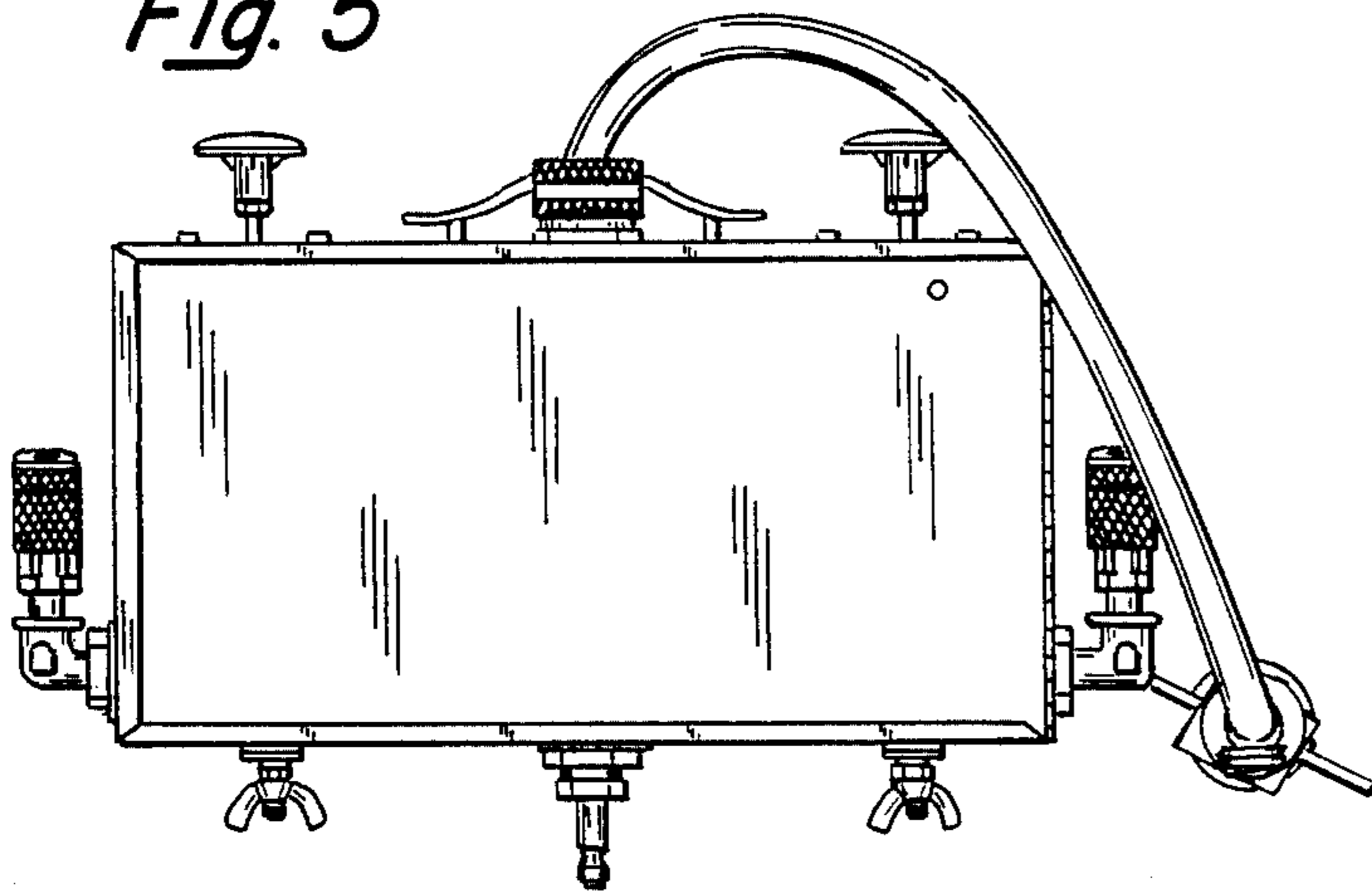

Fig. 6

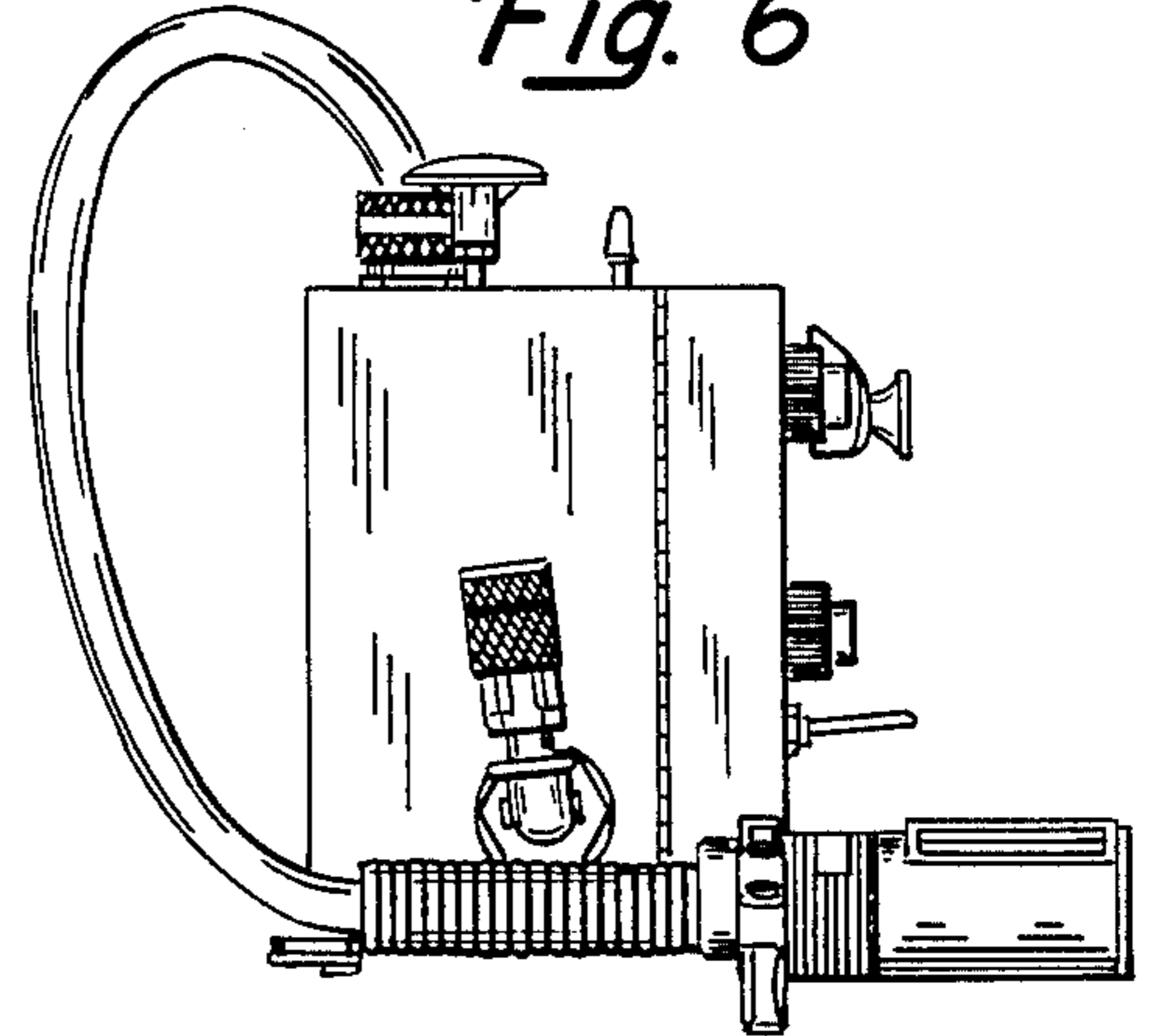

Fig. 7

