

[54] SPILL CONTAINMENT SYSTEM TROUGH UNIT WITH WEIR FLANGE

[75] Inventor: William T. Breadmont, Bakersfield, Calif.

[73] Assignees: Roy F. Saunders; James P. Peel, both of Bakersfield, Calif. ; a part interest to each

[**] Term: 14 Years

[21] Appl. No.: 10,802

[22] Filed: Feb. 4, 1987

[52] U.S. Cl. D23/200; D23/206

[58] Field of Search D23/205, 200, 202, 204, D23/206; 220/1 B, 1 C, 85 S, 3, 22.1, 401, 410, 470; 206/557, 0.6; 261/91; D6/475, 510, 511; D12/98; D34/40, 1, 3; 296/39.2

[56] References Cited

U.S. PATENT DOCUMENTS

D. 213,956	4/1969	Jones et al.	D23/200
D. 230,114	1/1974	Jennee	D6/510
D. 283,074	3/1986	Skillius	D34/40
3,139,627	7/1964	Rice	220/470
3,423,077	1/1969	Gloppen	261/91
4,653,958	3/1987	Anderson	405/157
4,682,911	9/1987	Moreland	405/53

FOREIGN PATENT DOCUMENTS

1246867	10/1960	France	D12/98
1260708	4/1961	France	D12/98
1512511	6/1978	United Kingdom	296/39.2

OTHER PUBLICATIONS

MPC Containment Systems, Ltd. Drawing Index-5 pages-9/12/84; 2 pages-12/16/85; 1 page-6/15/84; 1 page-9/12/84; 1 page-2/28/85, 1 page-10/1/84; 6 pages-11/15/84; 1 page-5/19/84; 1 page-purchase order.

Primary Examiner—James M. Gandy
Assistant Examiner—Lisa Lichtenstein
Attorney, Agent, or Firm—Fleit, Jacobson, Cohn, Price, Holman & Stern

[57] CLAIM

The ornamental design for a spill containment system trough unit with weir flange, as shown.

DESCRIPTION

FIG. 1 is a top perspective view of a spill containment system trough unit with weir flange, showing my new design;
FIG. 2 is a top plan view thereof;
FIG. 3 is a bottom plan view thereof;
FIG. 4 is a front elevation view thereof; and
FIG. 5 is a rear elevation view thereof.

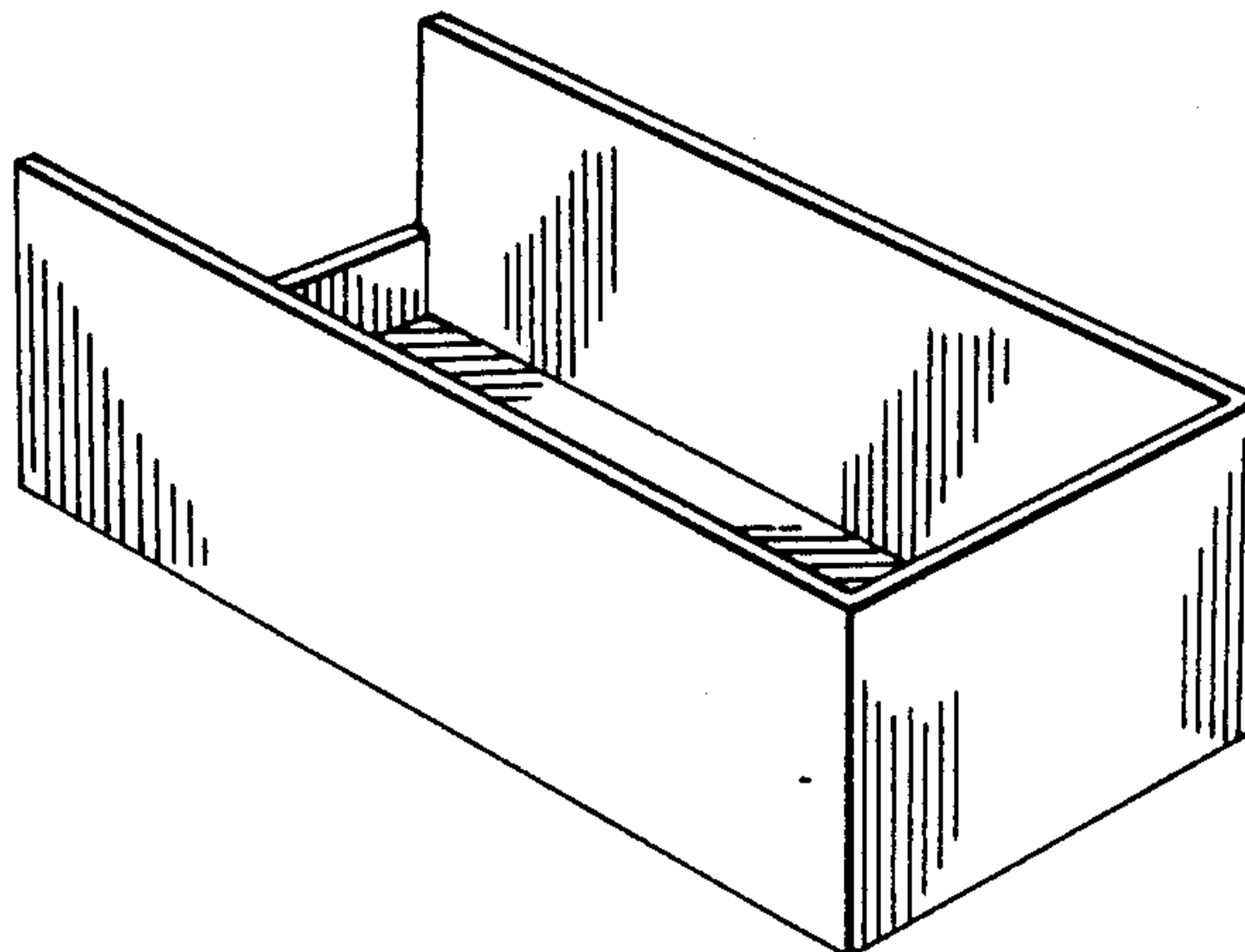

FIG. 1

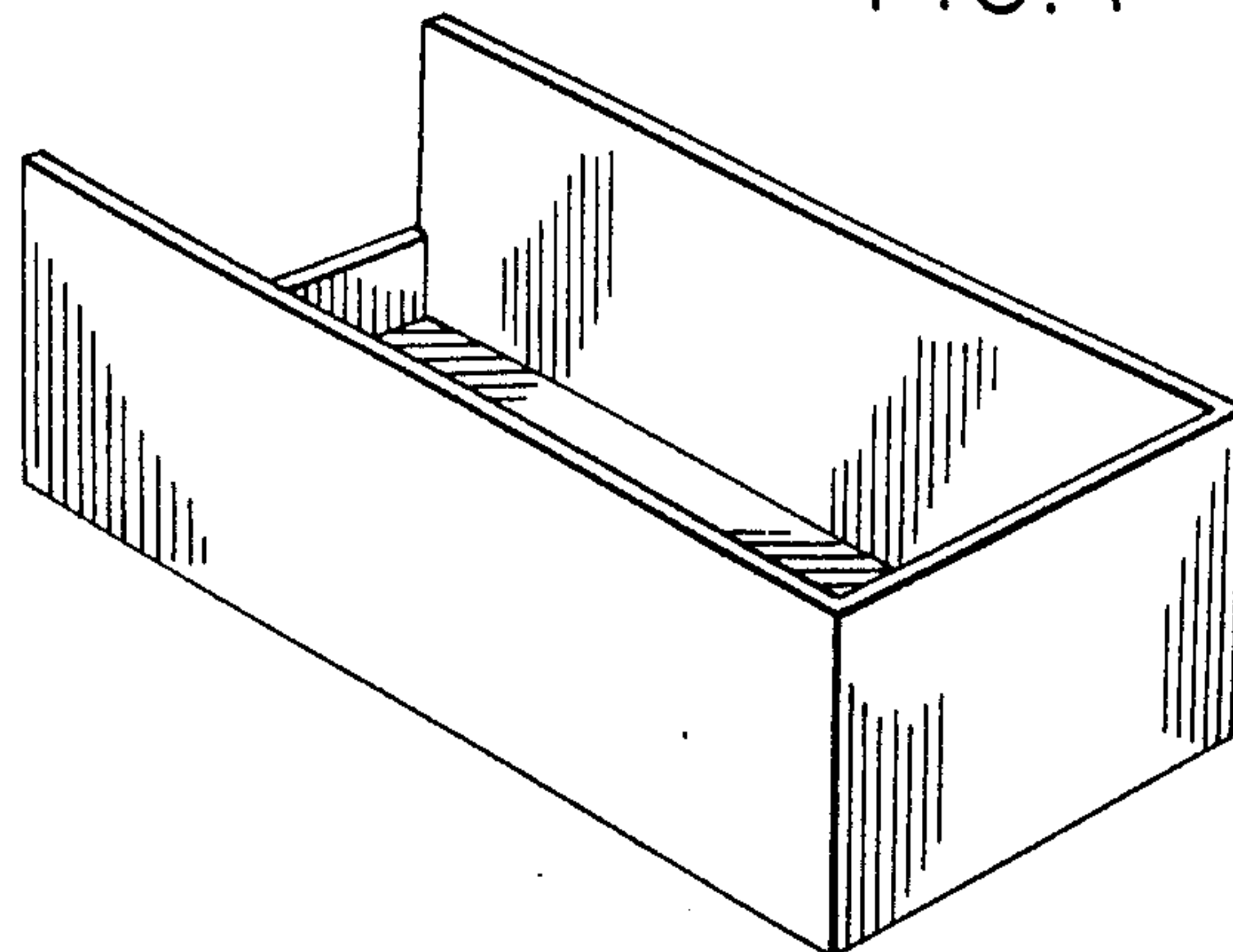

FIG. 2

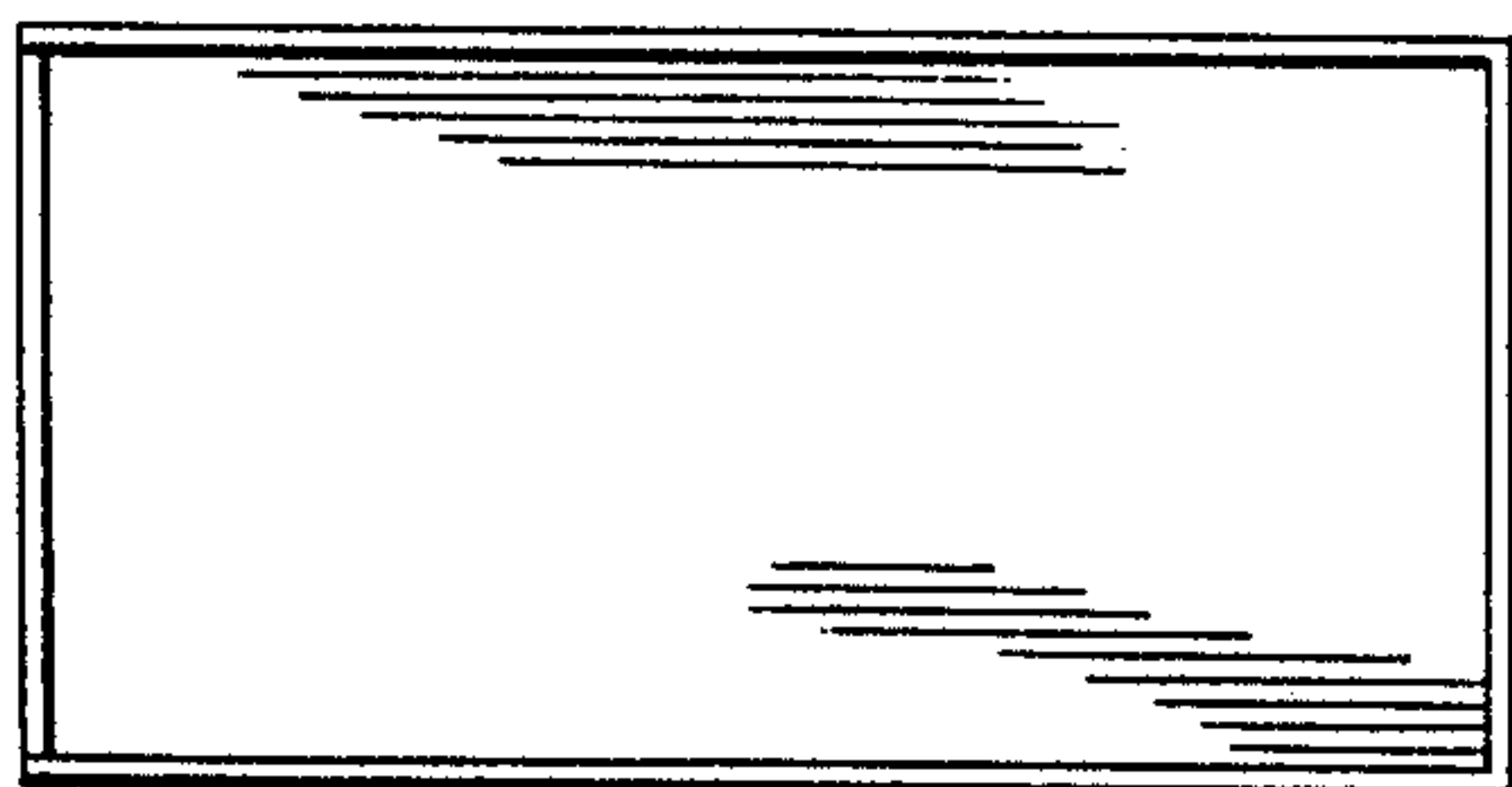

FIG. 3

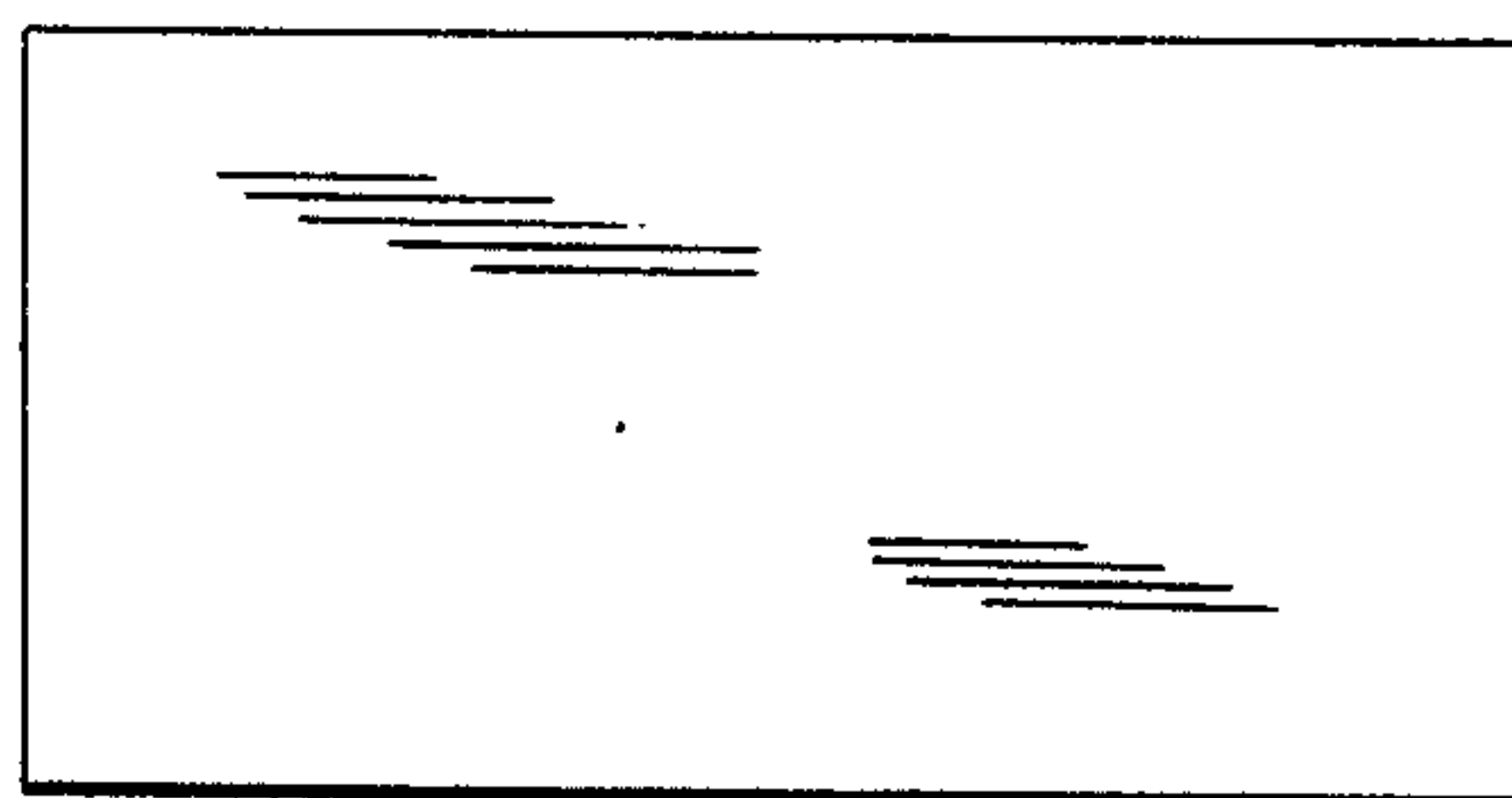

FIG. 4

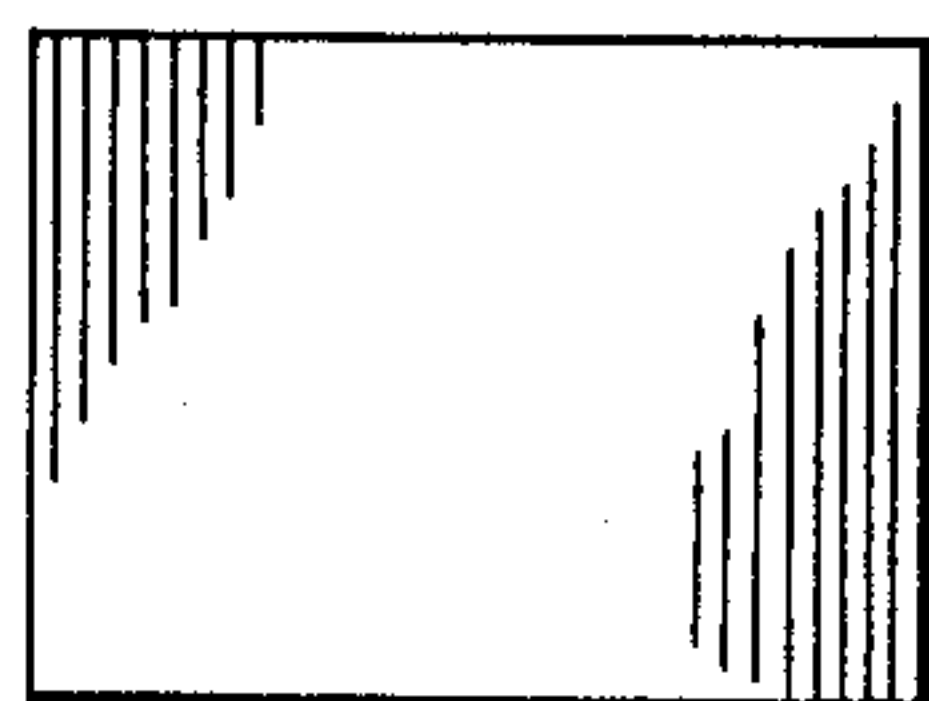

FIG. 5

