

[54] THERMOMETER FOR VEHICLES

[75] Inventor: Yoshihisa Tanaka, Ichikawa, Japan

[73] Assignee: 501 Tanaka Manufacturing Company Limited, Tokyo, Japan

[\*\*] Term: 14 Years

[21] Appl. No.: 24,799

[22] Filed: Mar. 11, 1987

[30] Foreign Application Priority Data

Sep. 12, 1986 [JP] Japan ..... 61-35779

[52] U.S. Cl. .... D10/57

[58] Field of Search ..... D10/50, 51, 52, 53, D10/54, 55, 56, 57, 58, 59, 60, 98, 102, 103; D12/155, 192, 188; 33/355 R; 73/431, 432; 206/306; 374/141, 142, 143, 144, 187, 198, 203, 208, 138; D8/349, 395, 394, 399; 24/455

[56] References Cited

U.S. PATENT DOCUMENTS

- D. 119,239 2/1940 Fischer ..... D12/188
- D. 126,193 4/1941 Brown ..... D10/57 X
- D. 132,316 5/1942 Putterman ..... D12/188
- D. 162,098 2/1951 Vacanti ..... D12/188
- D. 205,923 10/1966 McCormick ..... D8/395 X
- D. 206,820 1/1967 Bieger et al. .... D10/57
- D. 242,431 11/1976 Carroll ..... D8/395 X

- D. 279,963 8/1985 Tanaka ..... D10/57
- D. 283,844 5/1986 Saad et al. .... D8/395 X
- D. 288,536 3/1987 Tanaka ..... D10/52 X
- D. 288,537 3/1987 Tanaka ..... D10/57
- 2,839,924 6/1958 Pauli ..... 374/138
- 4,336,712 6/1982 Hawkins ..... 374/141

FOREIGN PATENT DOCUMENTS

- 665073 4/1988 Switzerland ..... 24/455
- 8501760 4/1985 World Int. Prop. O. .... 24/455

Primary Examiner—Nelson C. Holtje  
Assistant Examiner—Antoine D. Davis  
Attorney, Agent, or Firm—Amster, Rothstein & Ebenstein

[57] CLAIM

The ornamental design for a thermometer for vehicles, as shown.

DESCRIPTION

FIG. 1 is a front elevational view of a thermometer for vehicles showing my new design; FIG. 2 is a rear elevational view; FIG. 3 is a top plan view, the bottom plan view being identical; FIG. 4 is a left side elevational view, the right side elevational view being identical; and FIG. 5 is a top, front, and left side perspective view thereof.

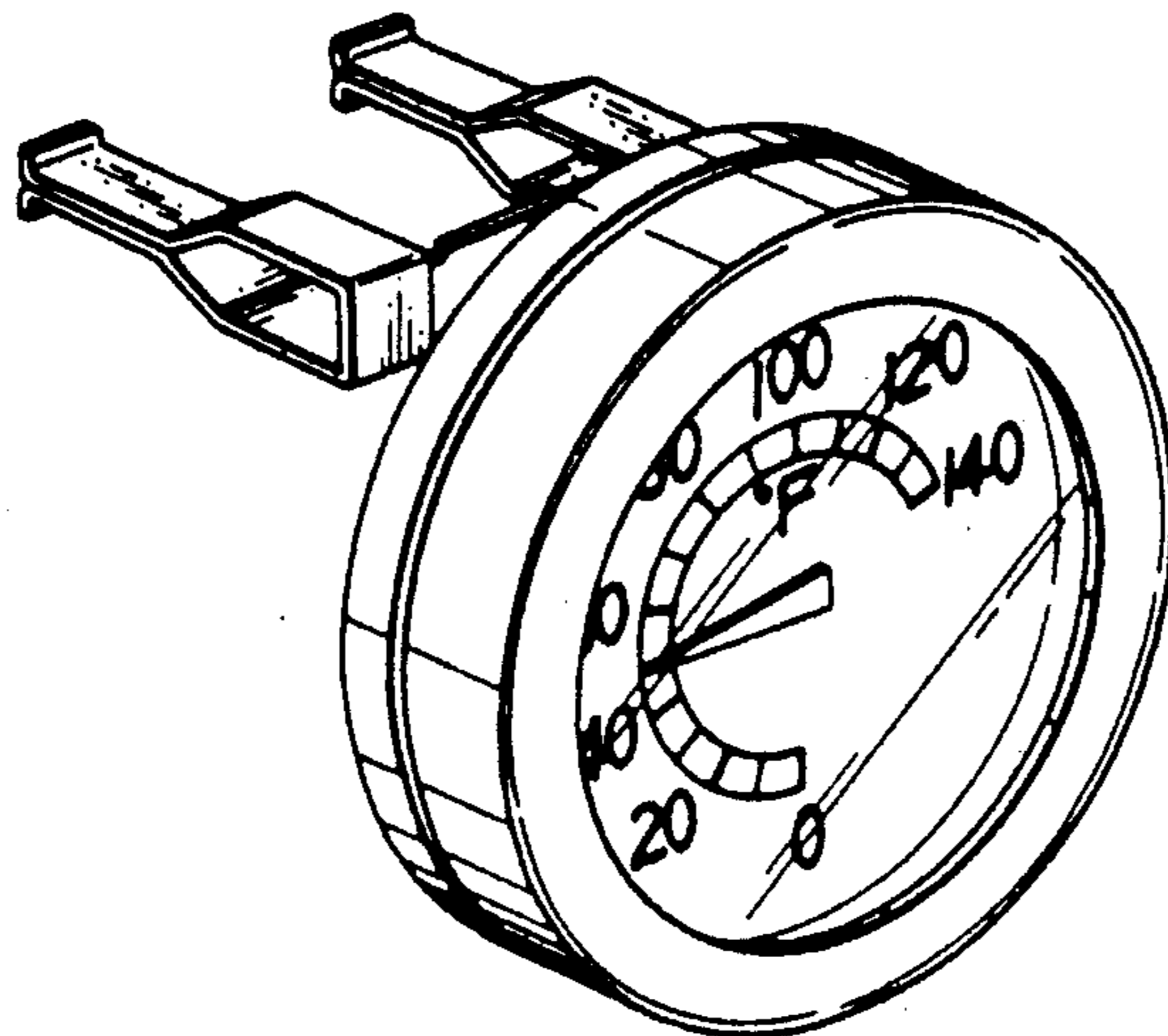

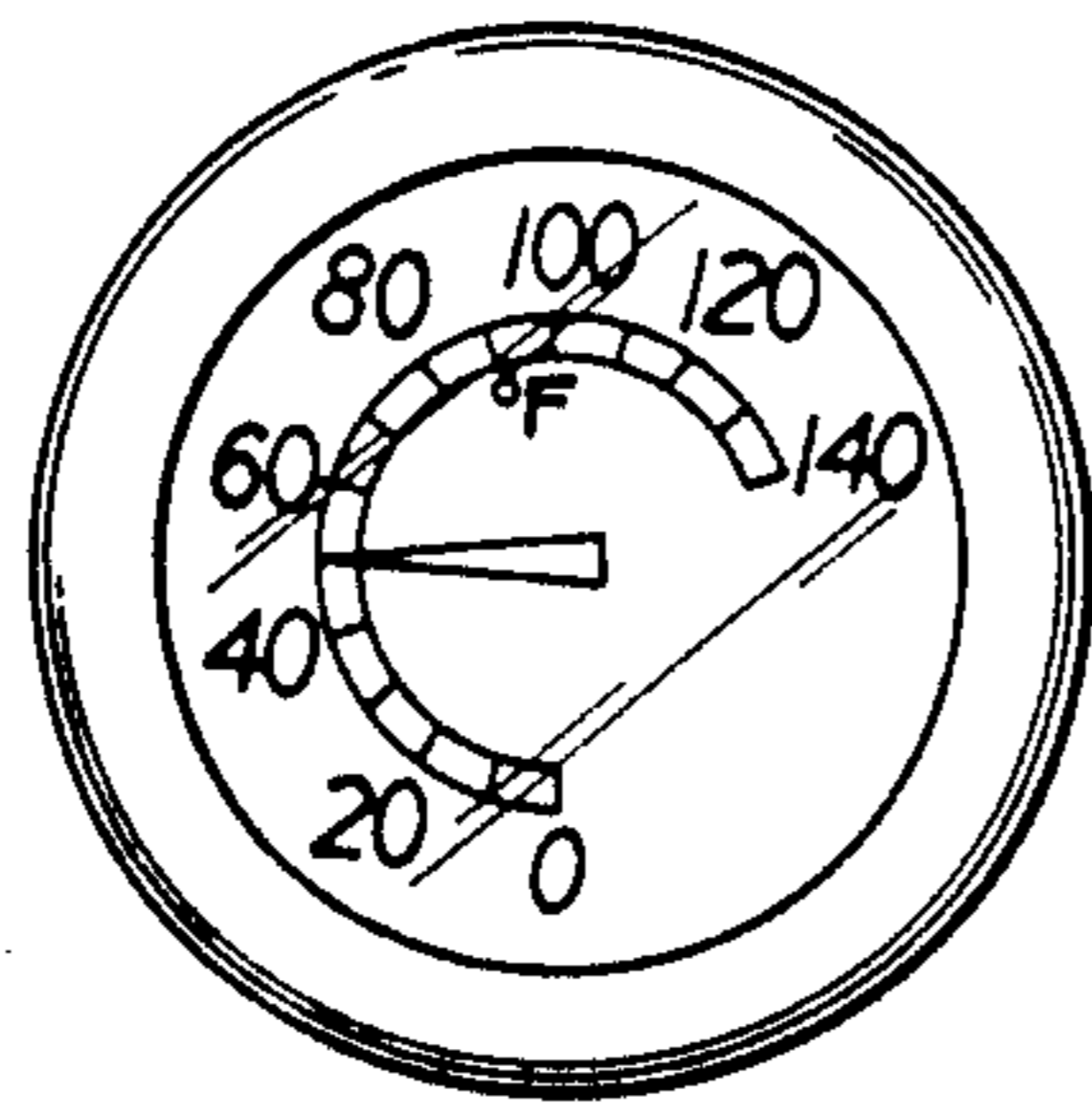

FIG. 1

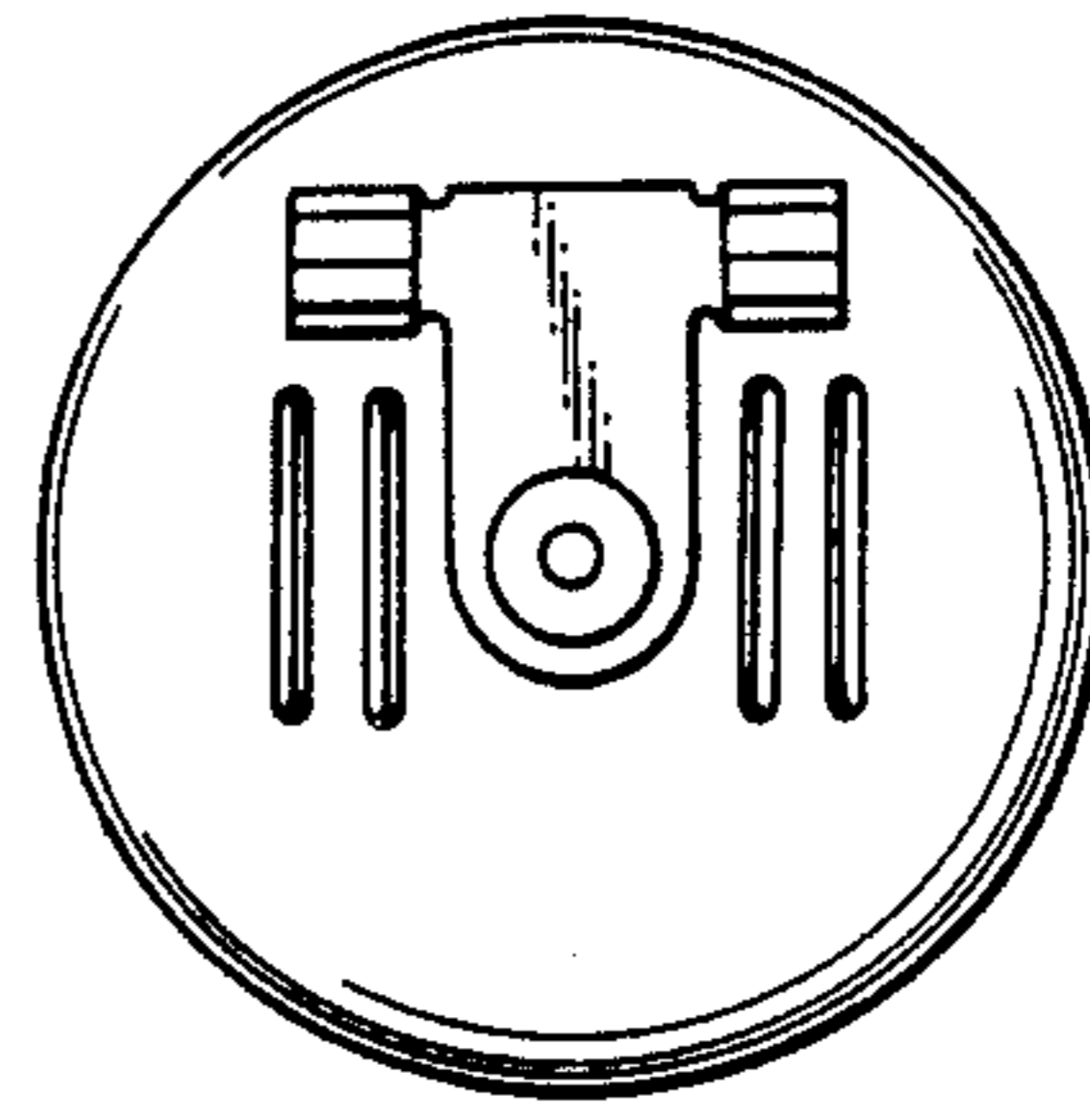

FIG. 2

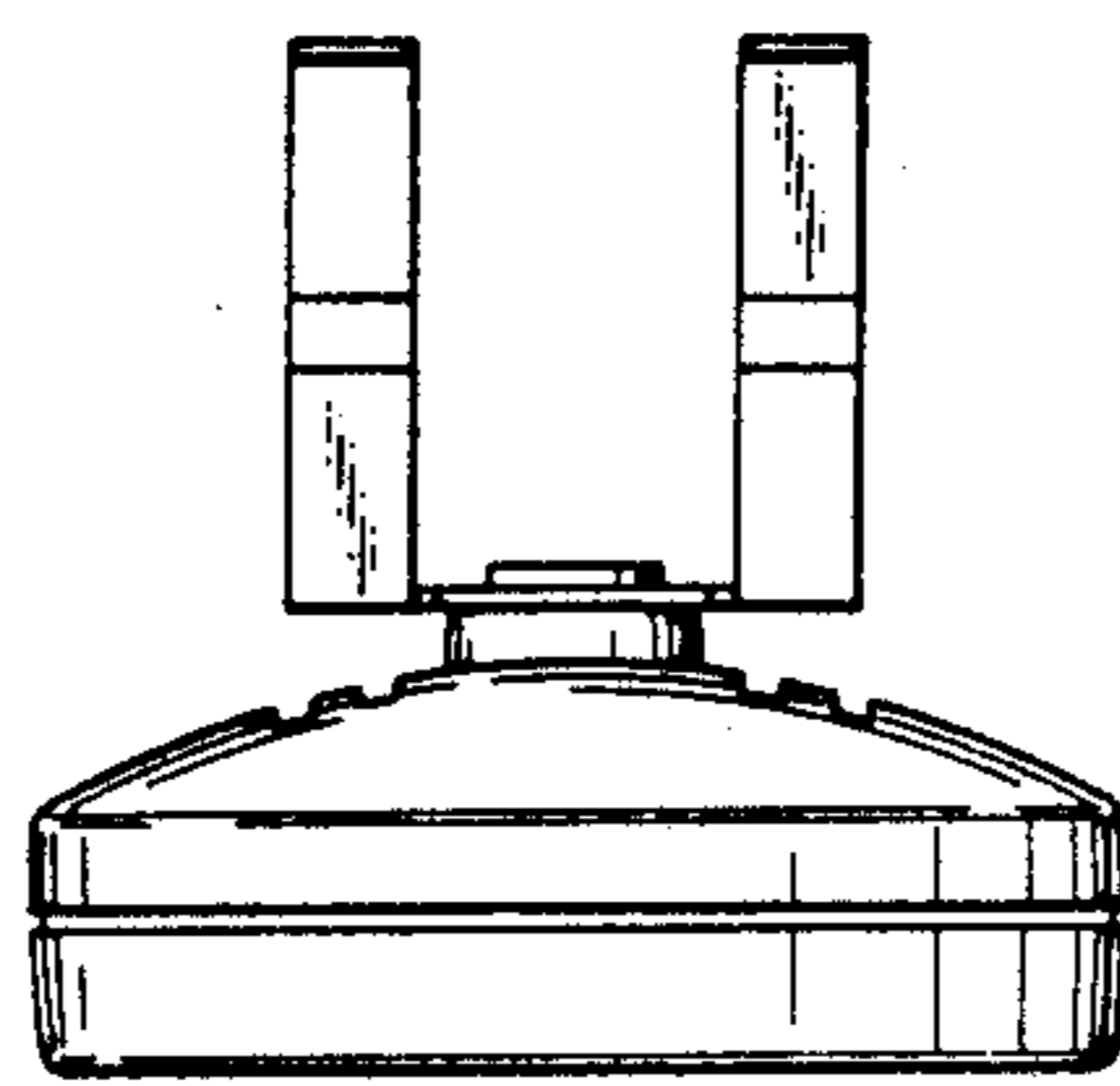

FIG. 3

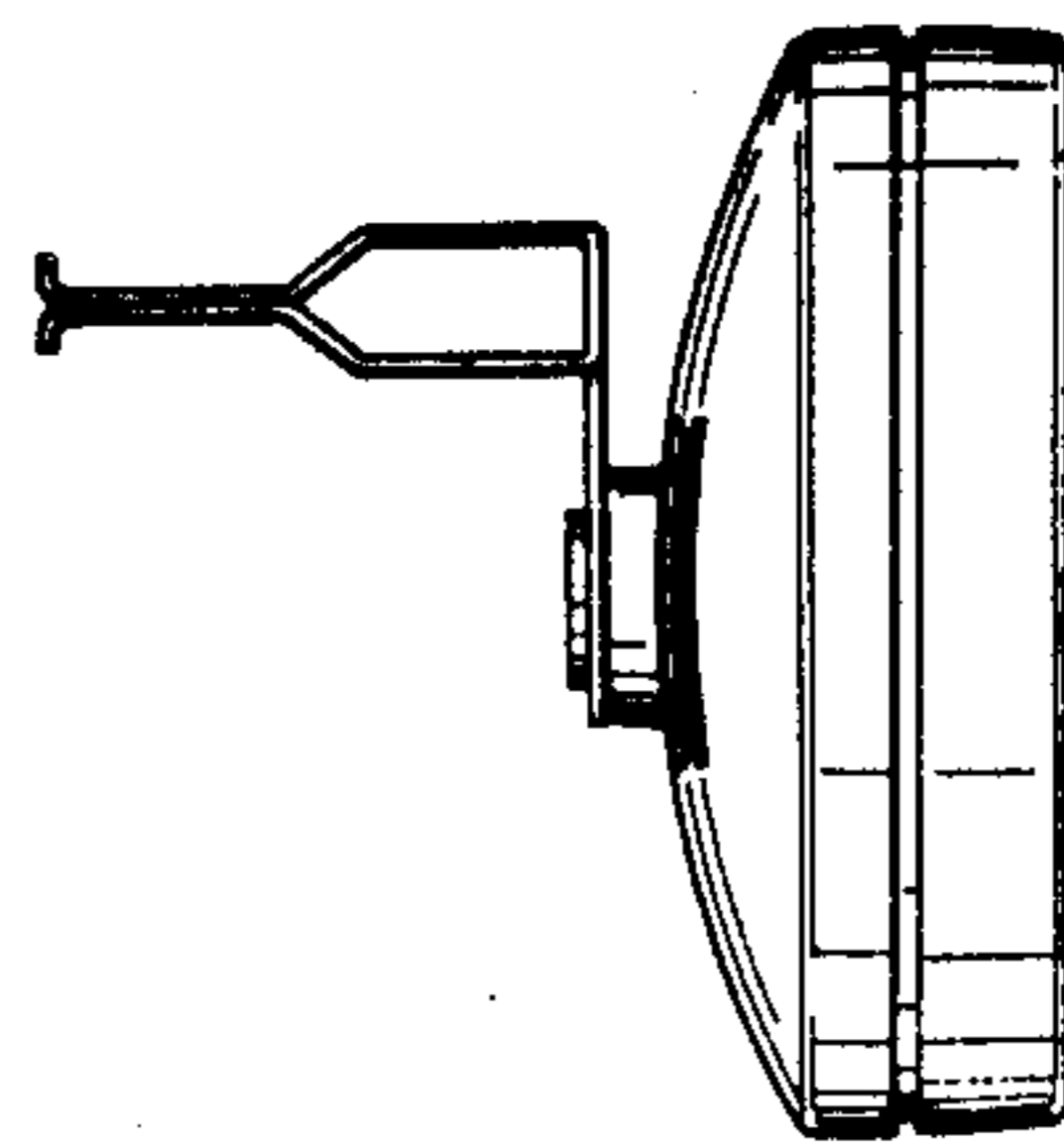

FIG. 4

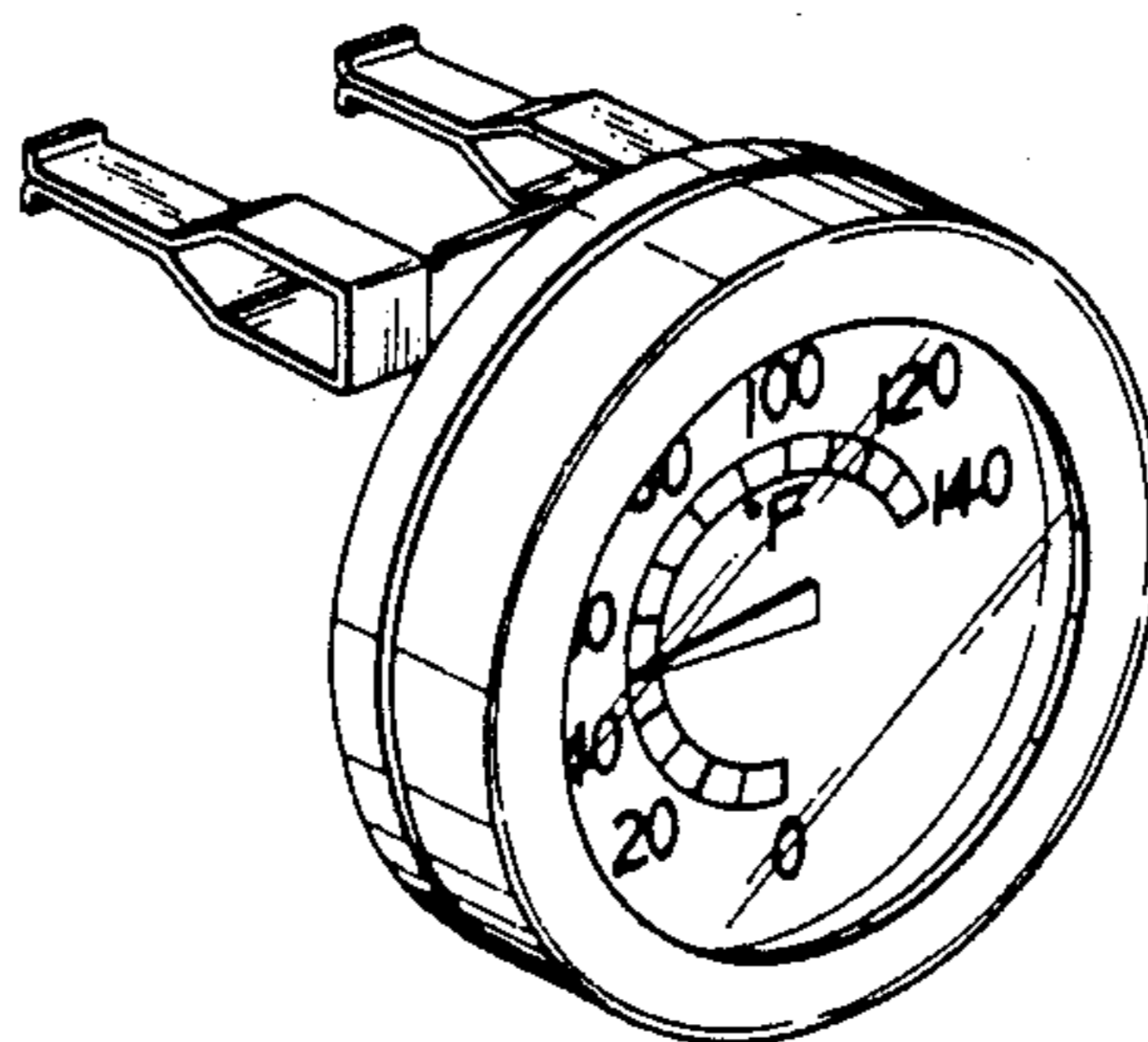

FIG. 5