

[54] **SPARK PLUG INSERTER/REMOVER**

[76] **Inventor: Michael Reed, 13749 Harold St., Taylor, Mich. 48180**

[**] **Term: 14 Years**

[21] **Appl. No.: 78,489**

[22] **Filed: Jul. 27, 1987**

[52] **U.S. Cl. D8/14**

[58] **Field of Search D8/14, 21, 107, 29; 81/53.11, 53.12, 177.1, 177.2, 64, 125**

[56] **References Cited**

U.S. PATENT DOCUMENTS

D. 155,489	10/1949	De Mesquita	D8/14 X
1,888,222	11/1932	Curtis et al.	81/177.1
2,513,509	7/1950	Morts	8/177.1
2,566,257	8/1951	Strunk	81/125
2,634,641	4/1953	Hodges	81/125
3,245,446	4/1966	Morifuji	81/125
3,322,007	5/1967	Cunningham	81/125
3,452,373	7/1969	Vosbikian et al.	D8/29 X
4,244,246	1/1981	Gillett	81/125

FOREIGN PATENT DOCUMENTS

1131718 10/1956 France 81/177.1
229489 2/1925 United Kingdom 81/125

Primary Examiner—Bruce W. Dunkins
Assistant Examiner—Clare E. Heflin
Attorney, Agent, or Firm—Dykema Gossett

[57] **CLAIM**

The ornamental design for a spark plug inserter/remover, as shown and described.

DESCRIPTION

FIG. 1 is a side perspective view of a spark plug inserter/remover showing my new design.

FIG. 2 is a side elevational view thereof, all other side elevations being identical;

FIG. 3 is a left end elevational view thereof;

FIG. 4 is a right end elevational view thereof;

FIG. 5 is a cross-sectional view thereof, taken along the line 5—5 in FIG. 2;

The broken line showing of the spark plug and engine block in FIG. 1 is for illustrative purposes only and forms no part of the claimed design.

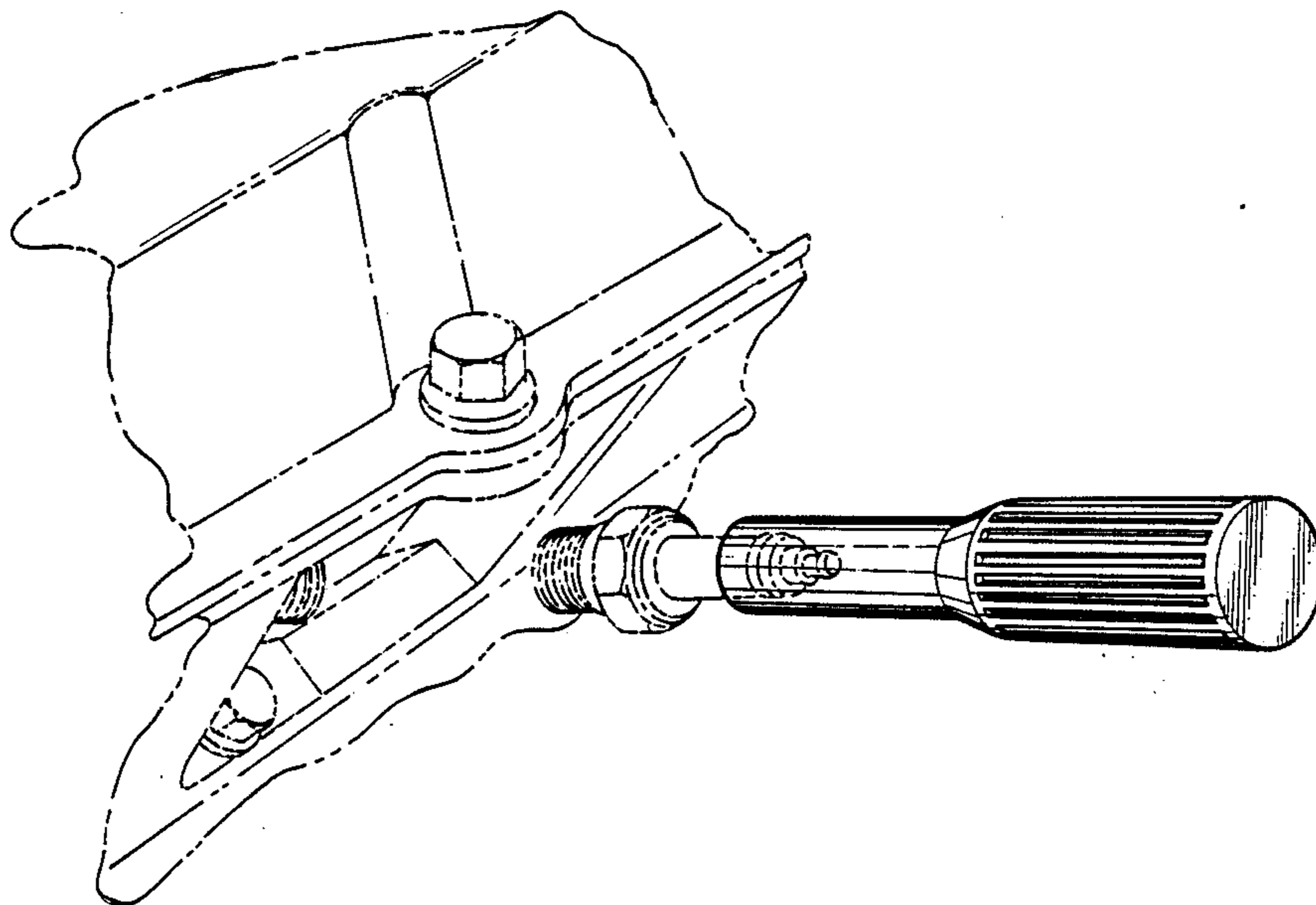

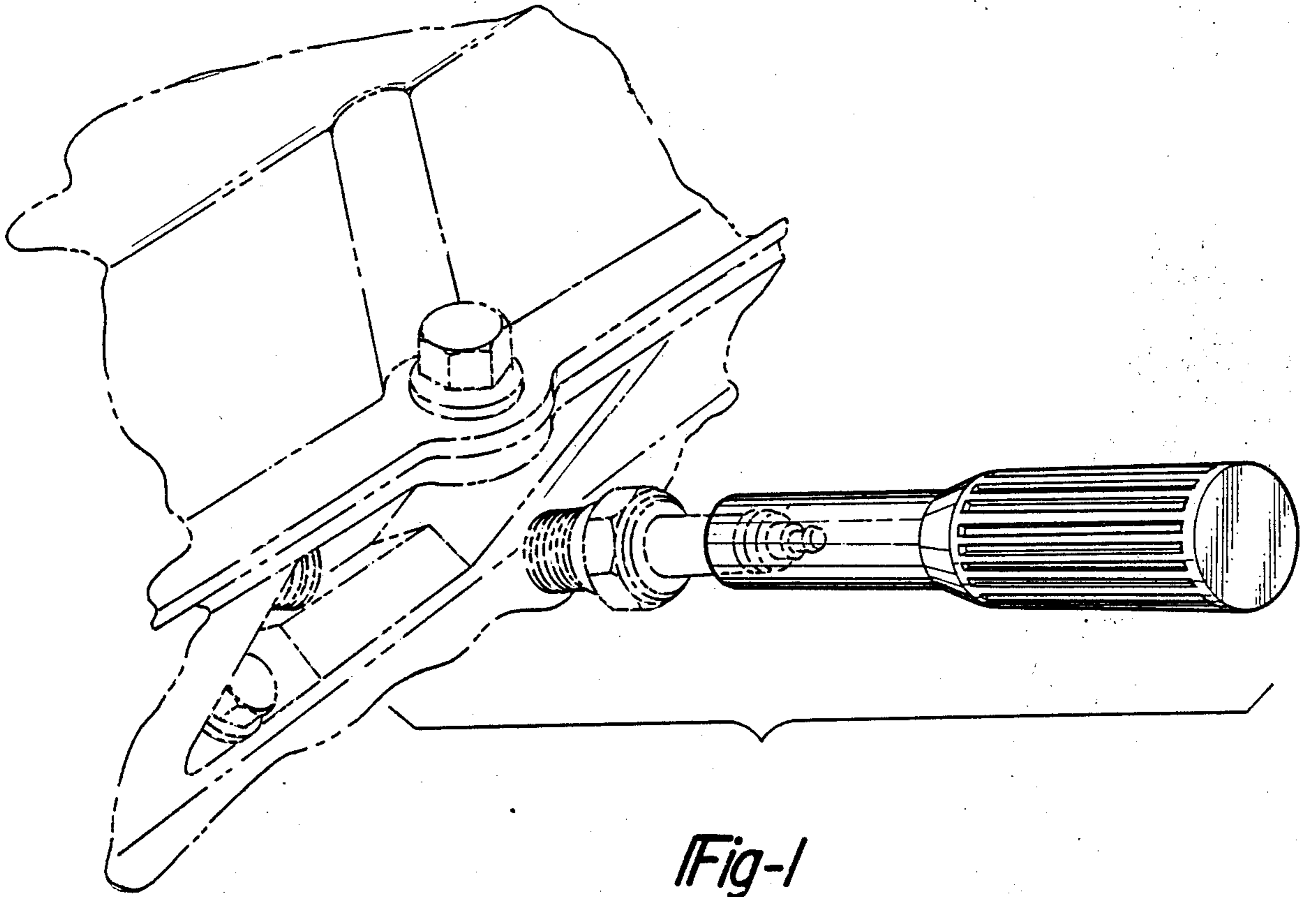

Fig-1

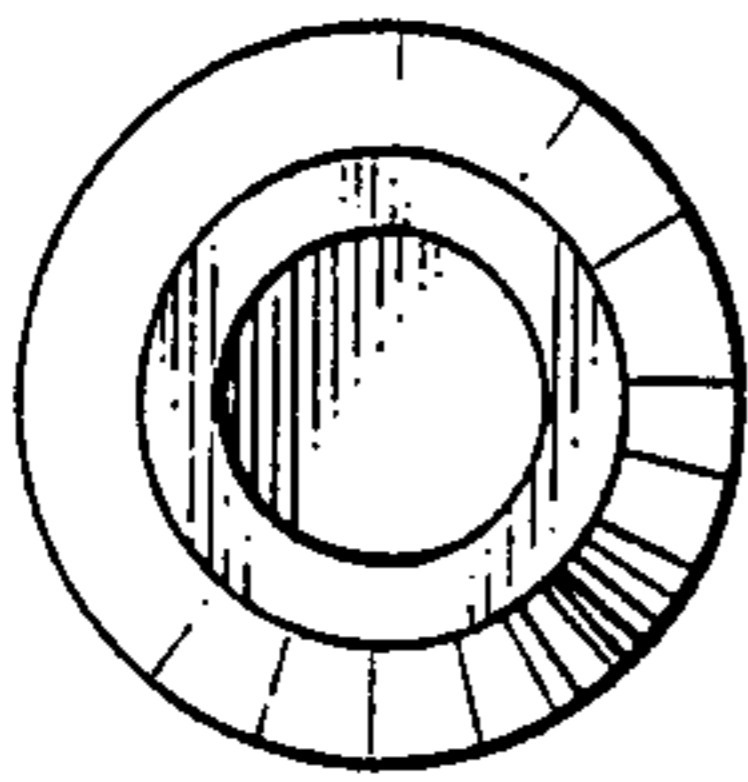

Fig-3

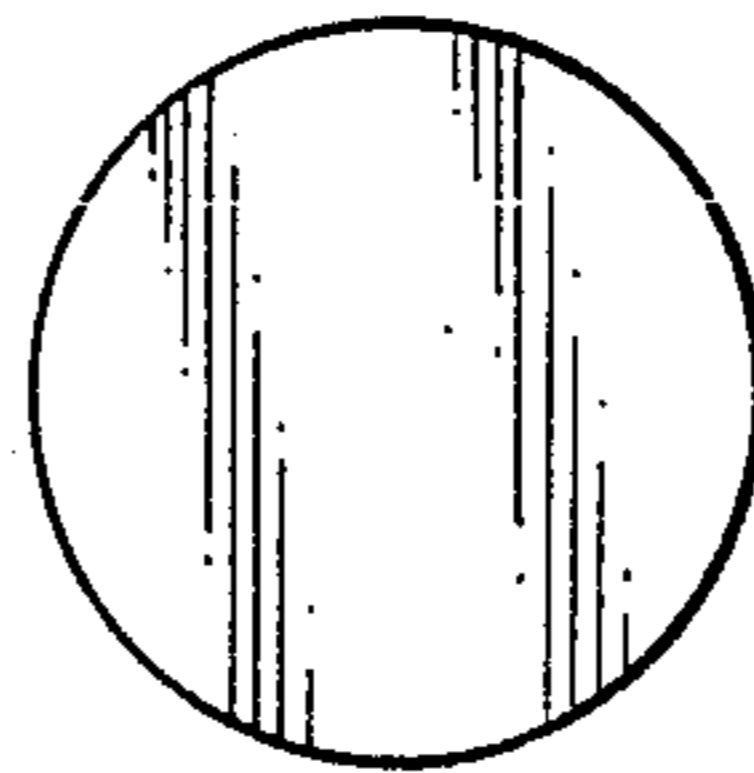

Fig-4

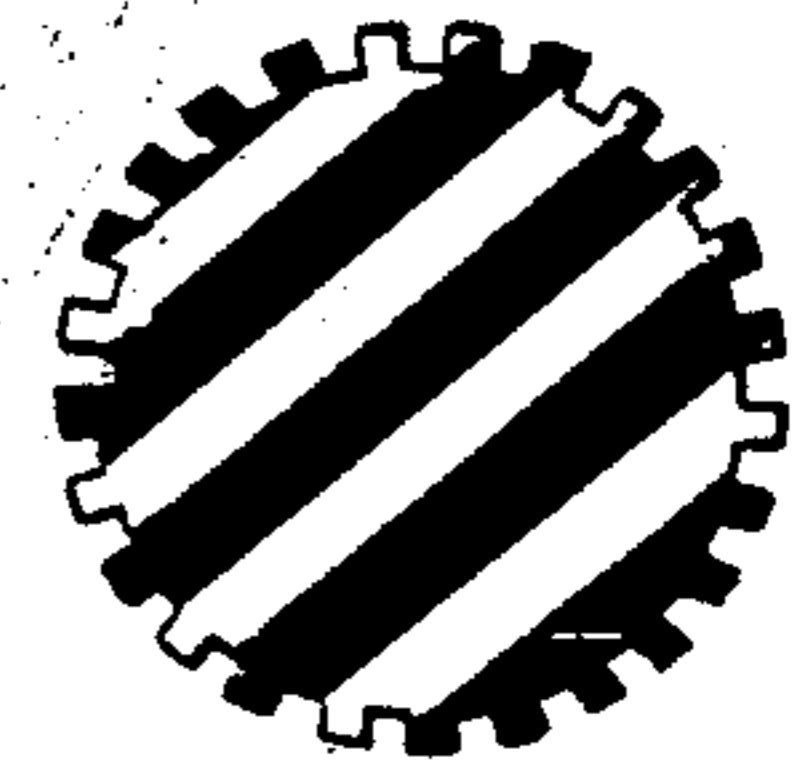

Fig-5

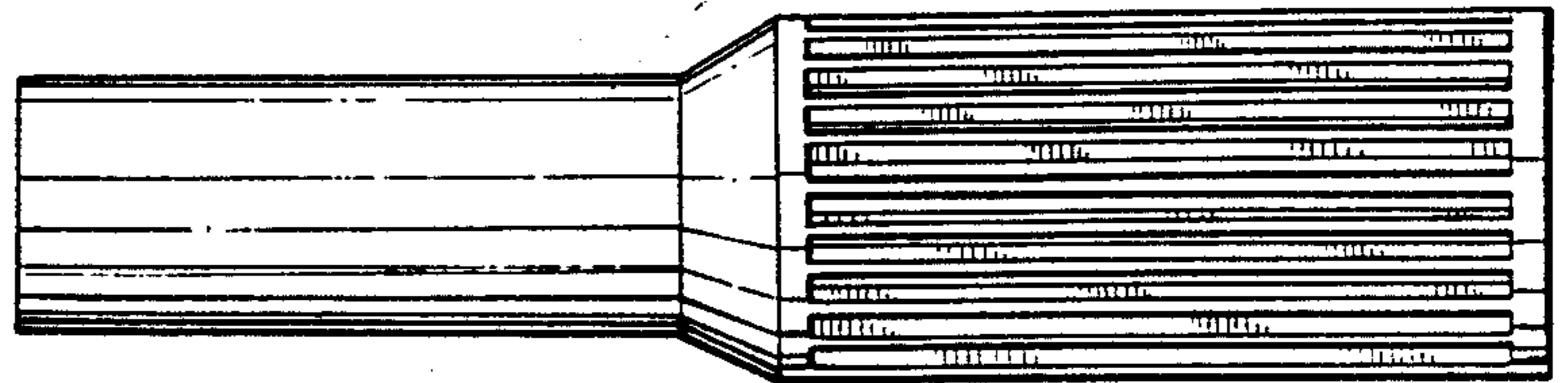
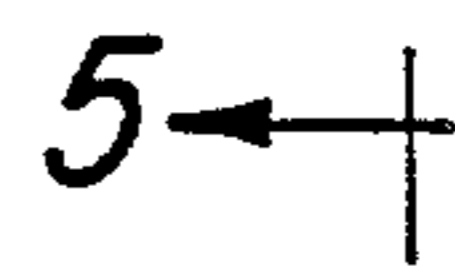

Fig-2