

[54] COMBINED CARRIER AND HANGER FOR FIREMAN'S GEAR

[76] Inventor: Eugene T. Welch, 38 Stratford Rd., Tinton Falls, N.J. 07724

[**] Term: 14 Years

[21] Appl. No.: 12,675

[22] Filed: Feb. 9, 1987

[52] U.S. Cl. D6/317; D6/327

[58] Field of Search D6/315, 317, 327; D20/42; D8/349; 211/13, 116, 113, 119, 96, 89; 223/85, 87, 88, 91, 92, 93, 95, 96

[56] References Cited

U.S. PATENT DOCUMENTS

D. 175,456	8/1955	Behlefeldt	D6/327
2,463,186	3/1949	Zasson	211/89
2,601,926	7/1952	Speaker et al.	D6/317
3,209,967	10/1965	Hasselback	D6/327
3,860,154	1/1975	Atkins	211/113
4,029,212	6/1977	Uadiski	211/113

4,278,177 7/1981 Fahmi 211/116

Primary Examiner—Wallace R. Burke

Assistant Examiner—Marcus Jackson

Attorney, Agent, or Firm—Shlesinger, Fitzsimmons & Shlesinger

[57] CLAIM

The ornamental design for a combined carrier and hanger for fireman's gear, as shown.

DESCRIPTION

FIG. 1 is a side elevational view of a combined carrier and hanger for fireman's gear showing one embodiment of my new design;

FIG. 2 is a front elevational view thereof;

FIG. 3 is a rear elevational view thereof;

FIG. 4 is a top plan view thereof;

FIG. 5 is a bottom plan view thereof;

FIG. 6 is a side elevational view of a second embodiment of my new design; and

FIG. 7 is a front elevational view of this second embodiment.

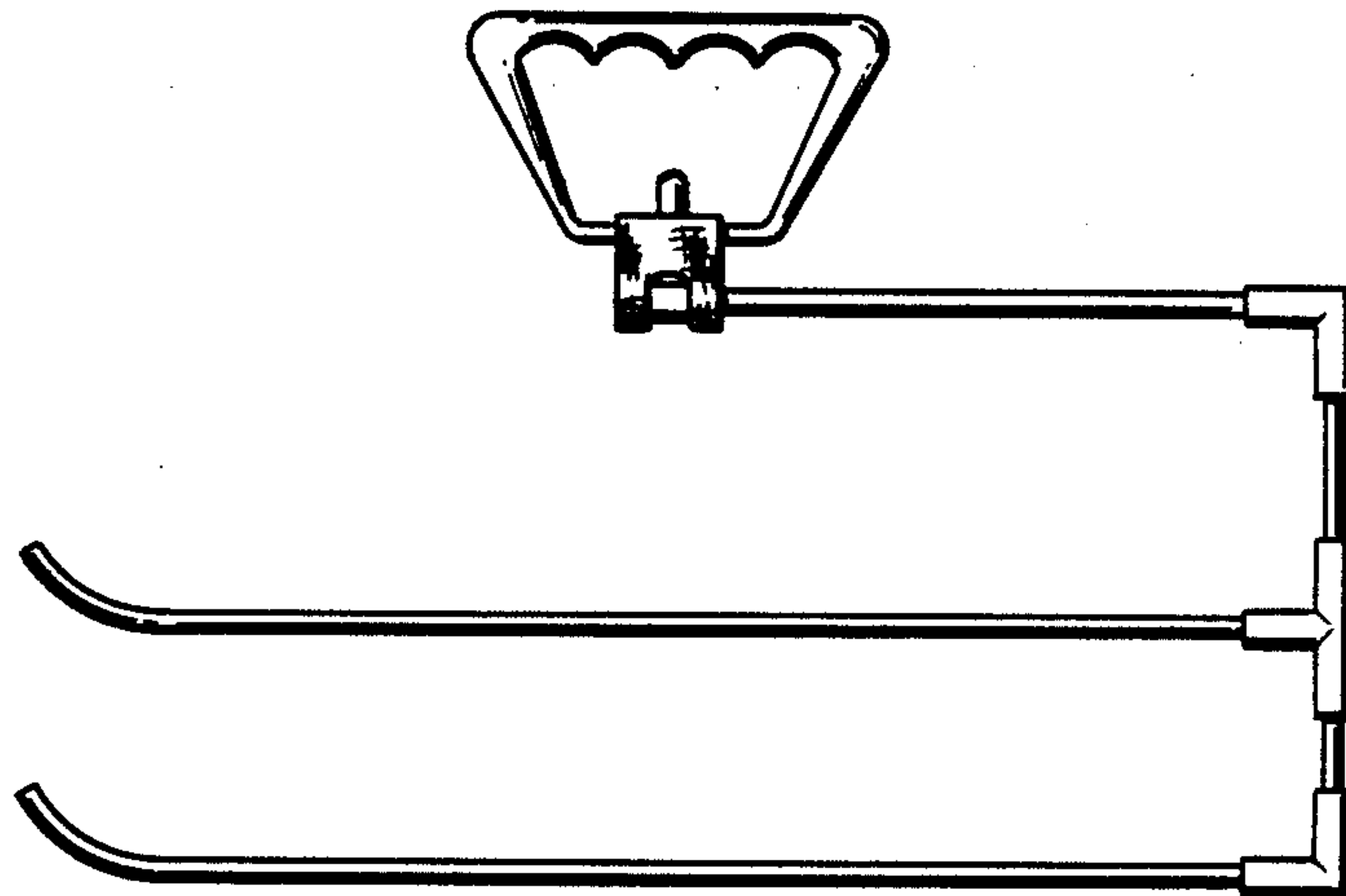
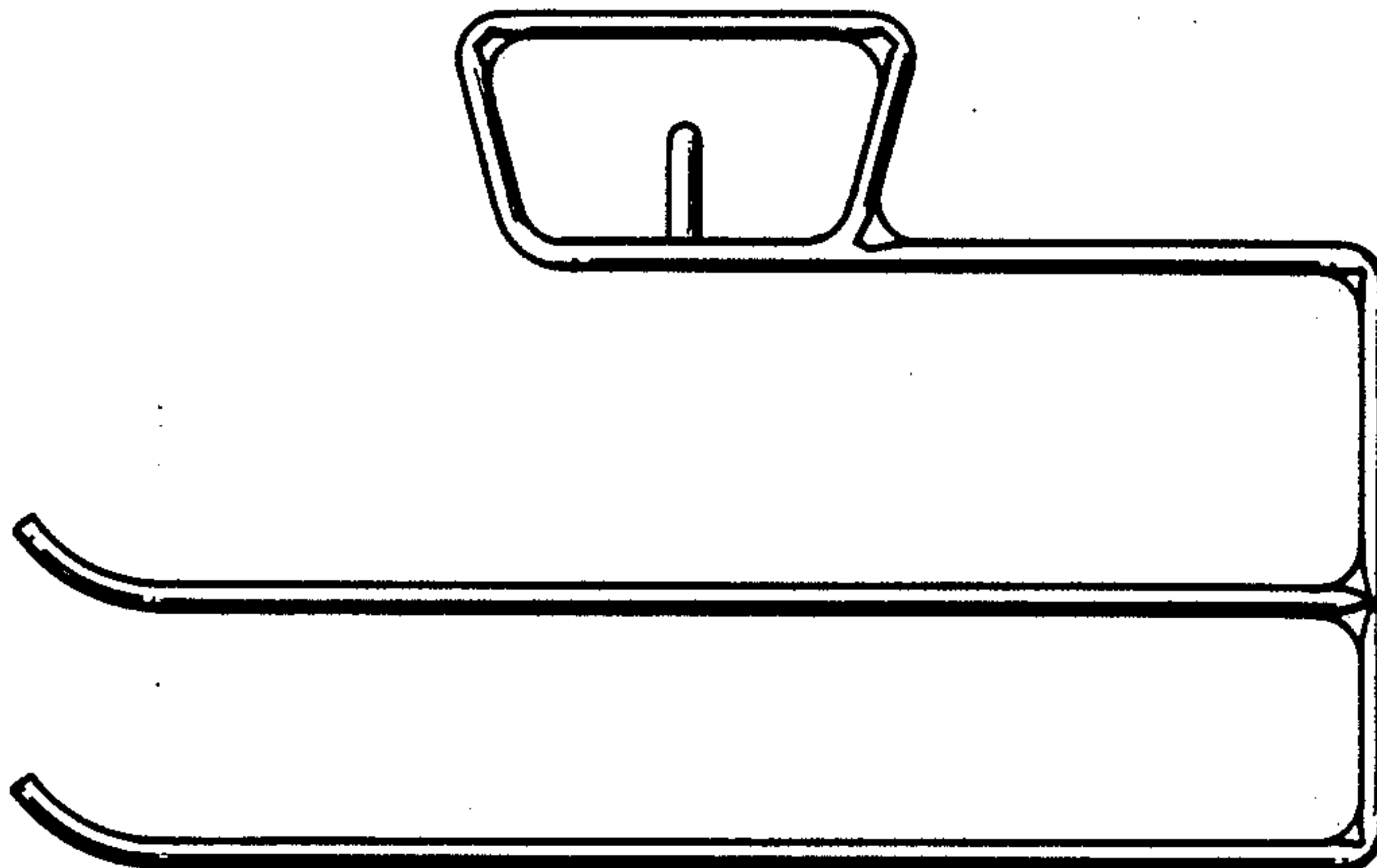

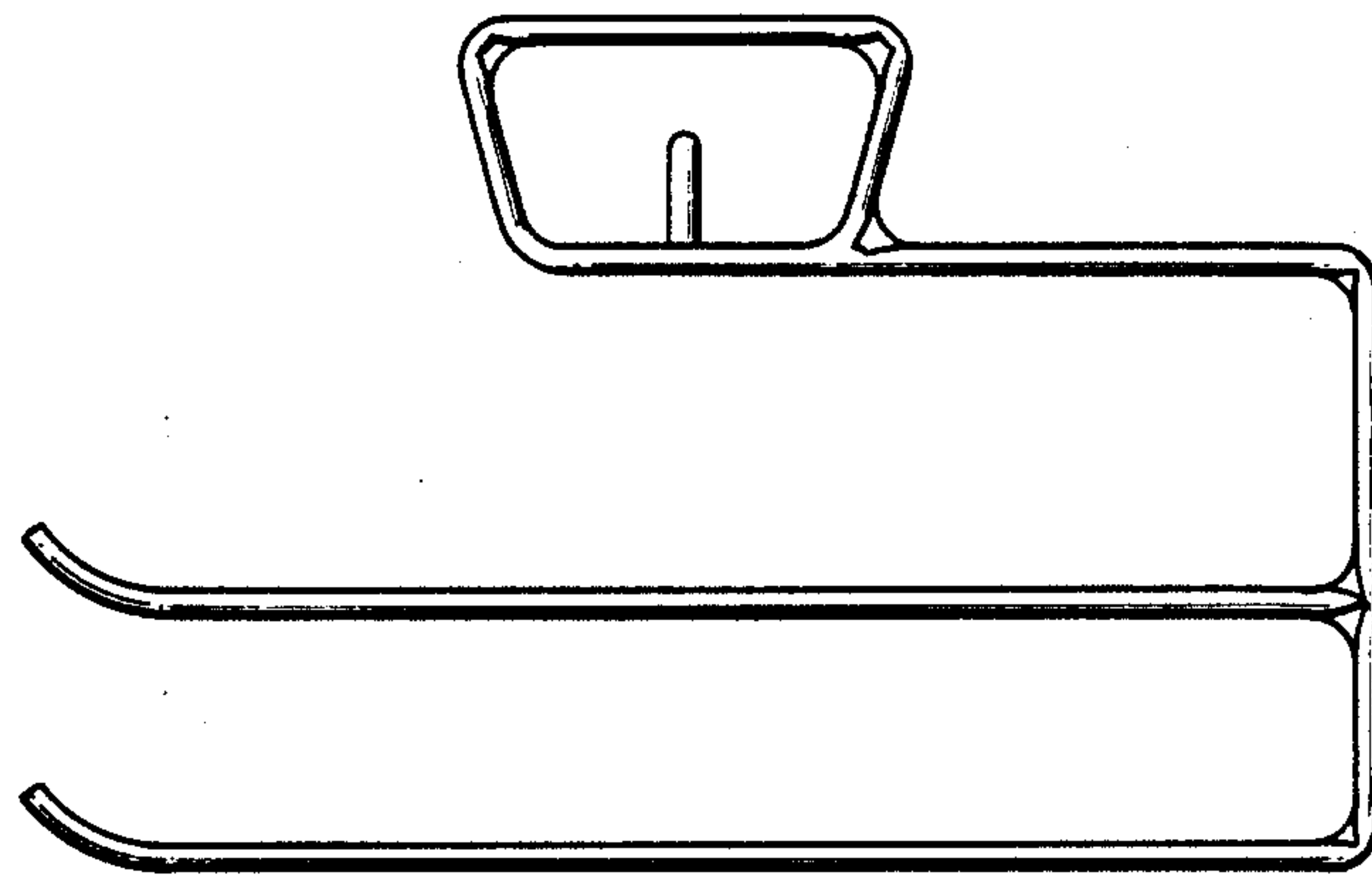

FIG. 1

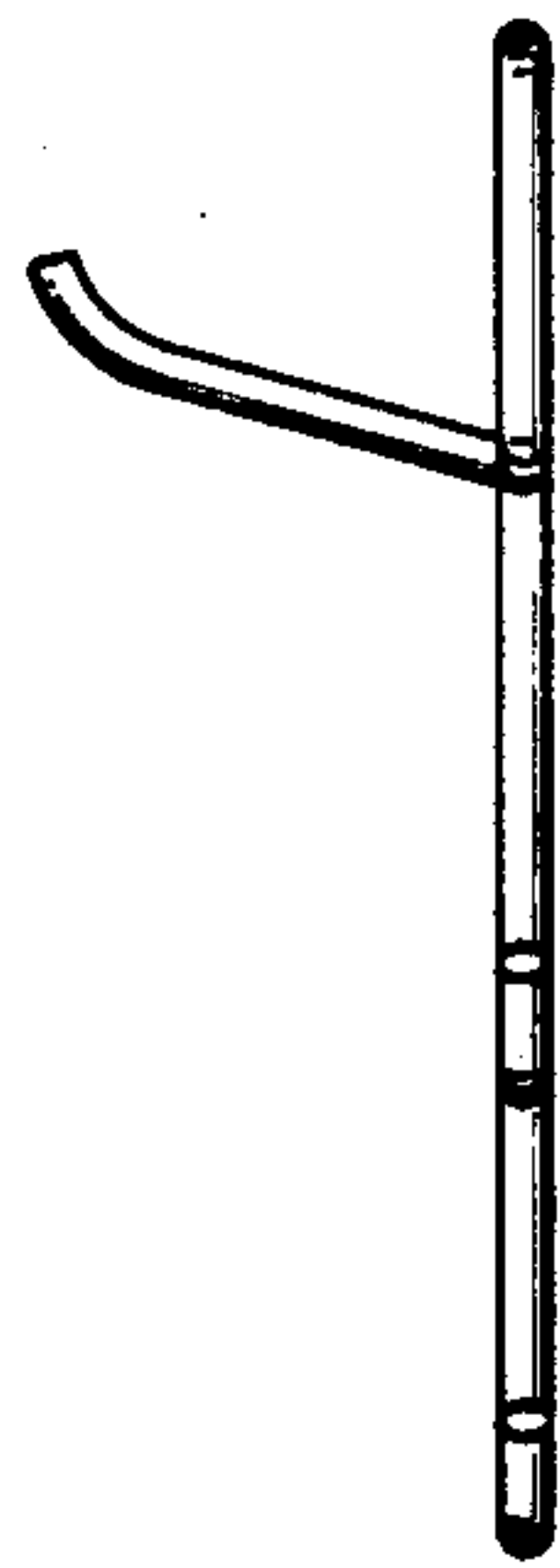

FIG. 2

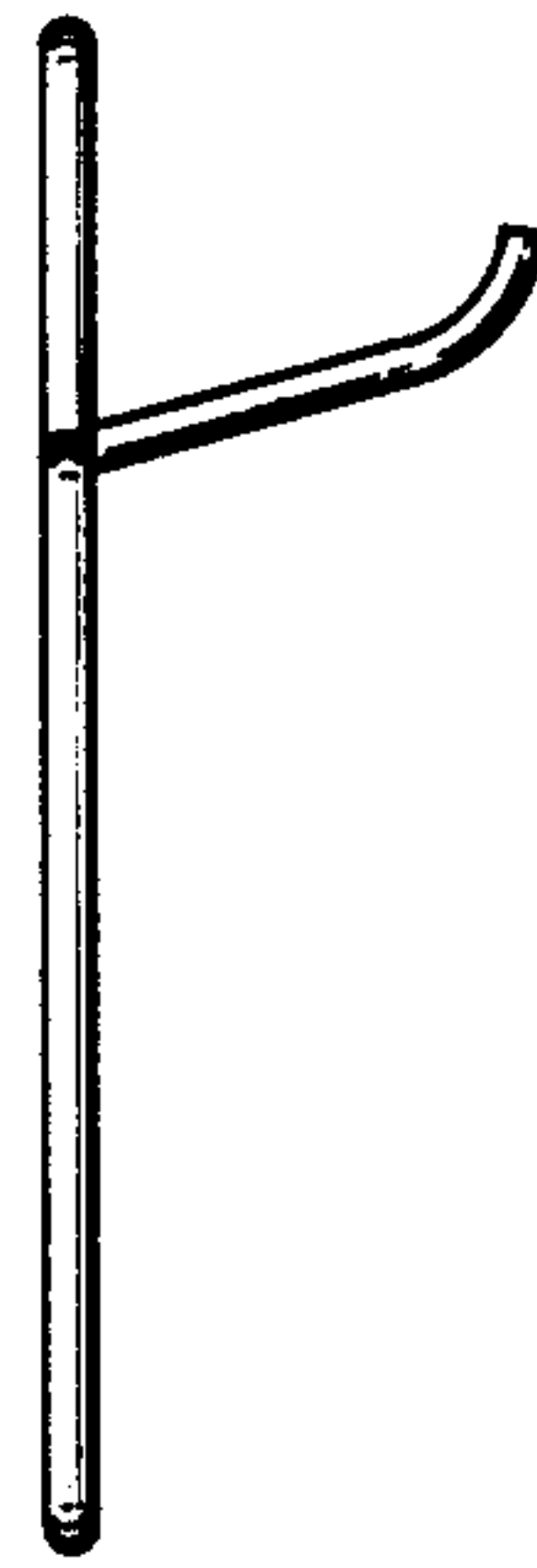

FIG. 3

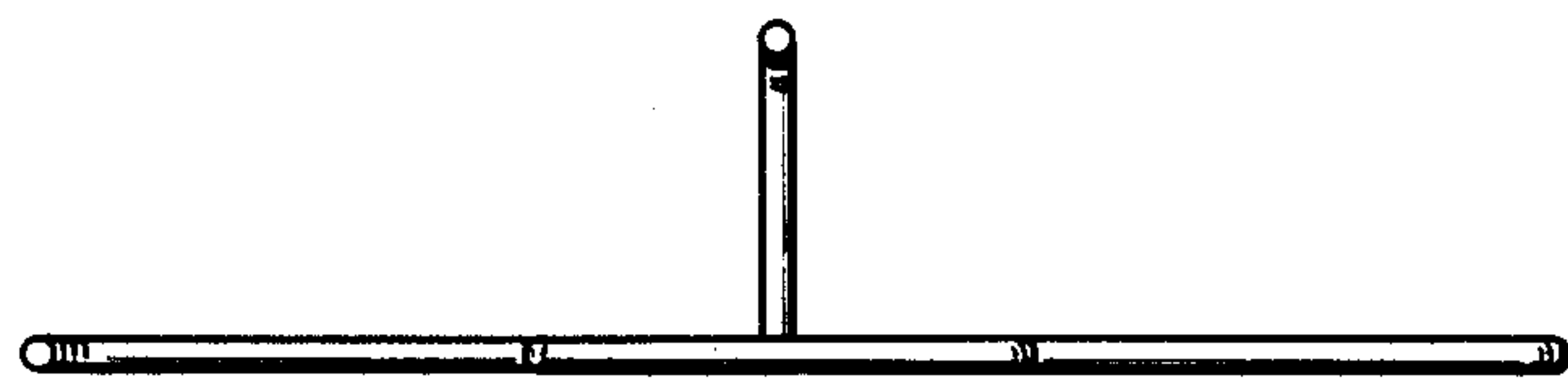

FIG. 4

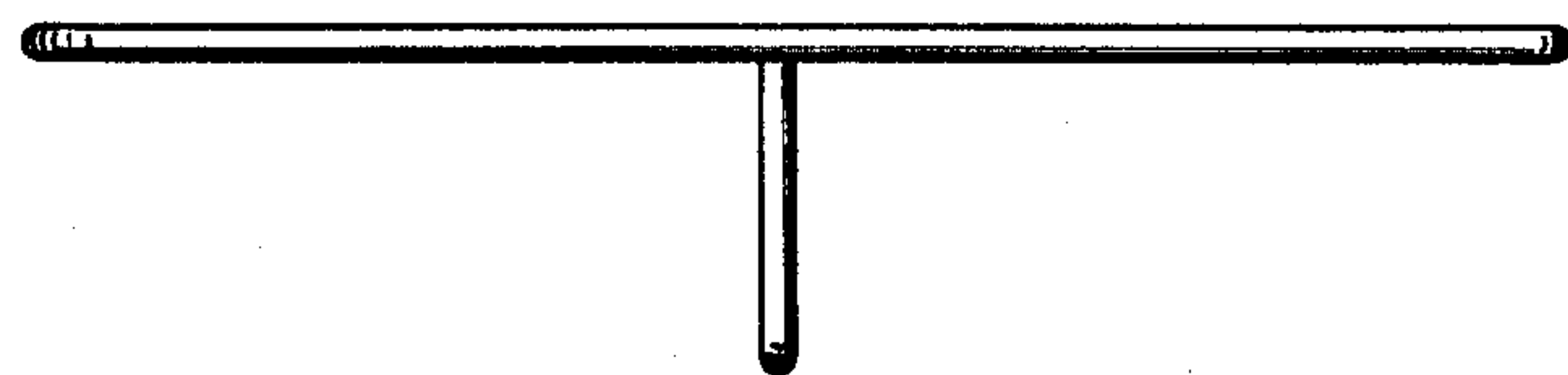

FIG. 5

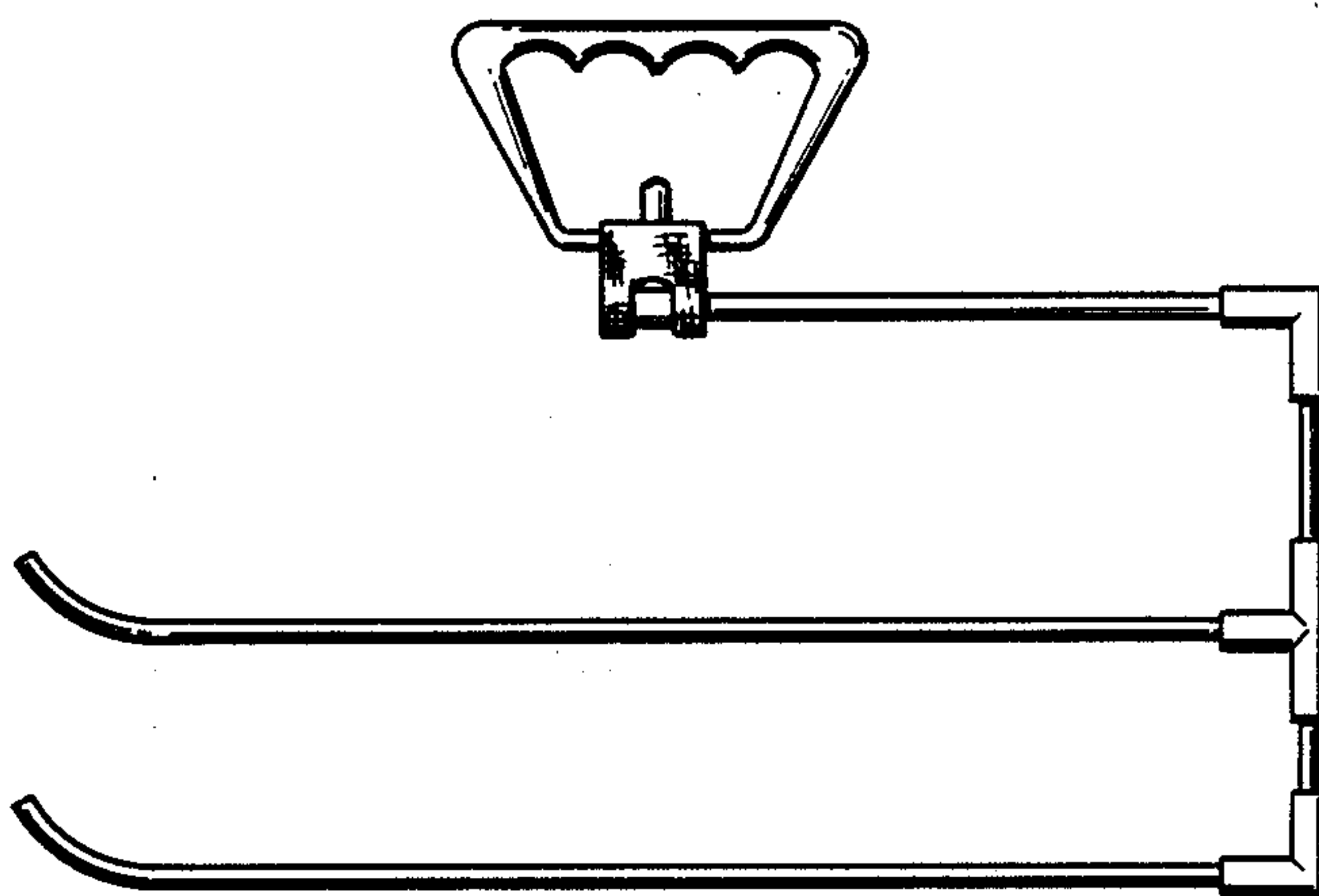

FIG. 6

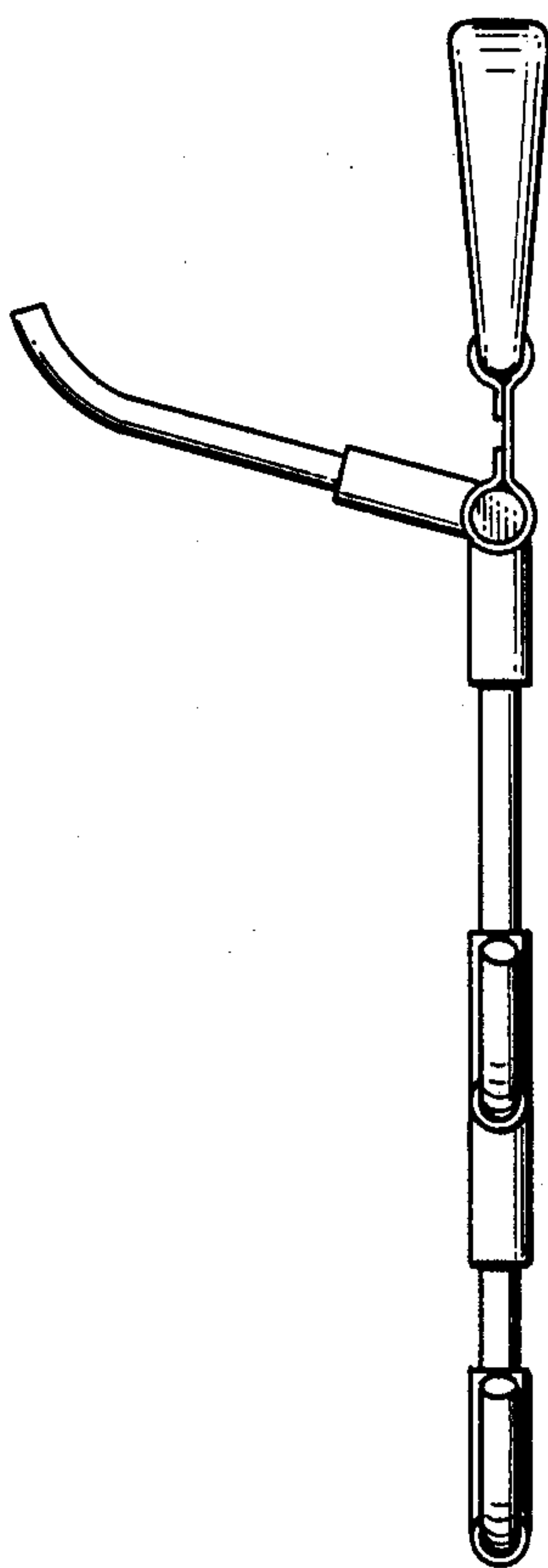

FIG. 7