

[54] MODEL AIRPLANE

[75] Inventor: Daniel M. Antonucci, 12 Earlswood Dr., Pittsburgh, Pa. 15228

[73] Assignees: Daniel M. Antonucci; David A. Celko, Pittsburgh, Pa.

[\*\*] Term: 14 Years

[21] Appl. No.: 164,986

[22] Filed: Feb. 29, 1988

[52] U.S. Cl. .... D21/89

[58] Field of Search ..... D21/82, 88, 89, 90; 244/153, 154, 155; 446/61-68

[56] References Cited

U.S. PATENT DOCUMENTS

- D. 60,825 4/1922 Shrum .
- D. 80,022 12/1929 Ebbinghaus .
- D. 132,103 4/1942 McCoy ..... D21/89
- D. 136,966 1/1944 Winer .
- D. 259,132 5/1981 Spizz ..... D21/89

- D. 261,288 10/1981 Hilko ..... D21/89
- D. 302,029 7/1989 Ninomiya ..... D21/89
- 1,644,362 10/1927 Wilson .
- 2,344,693 3/1944 Gade ..... 46/79
- 2,513,688 7/1950 Strong ..... 446/66
- 3,684,219 8/1972 King ..... 244/155 R

Primary Examiner—Charles A. Rademaker  
Attorney, Agent, or Firm—Arnold B. Silverman

[57] CLAIM

The ornamental design for a model airplane, as shown and described.

DESCRIPTION

FIG. 1 is a perspective view of a model airplane showing my new design;  
FIG. 2 is a front elevational view thereof;  
FIG. 3 is a right side elevational view thereof;  
FIG. 4 is a left side elevational view thereof;  
FIG. 5 is a rear elevational view thereof;  
FIG. 6 is a top plan view thereof; and,  
FIG. 7 is a bottom plan view thereof.

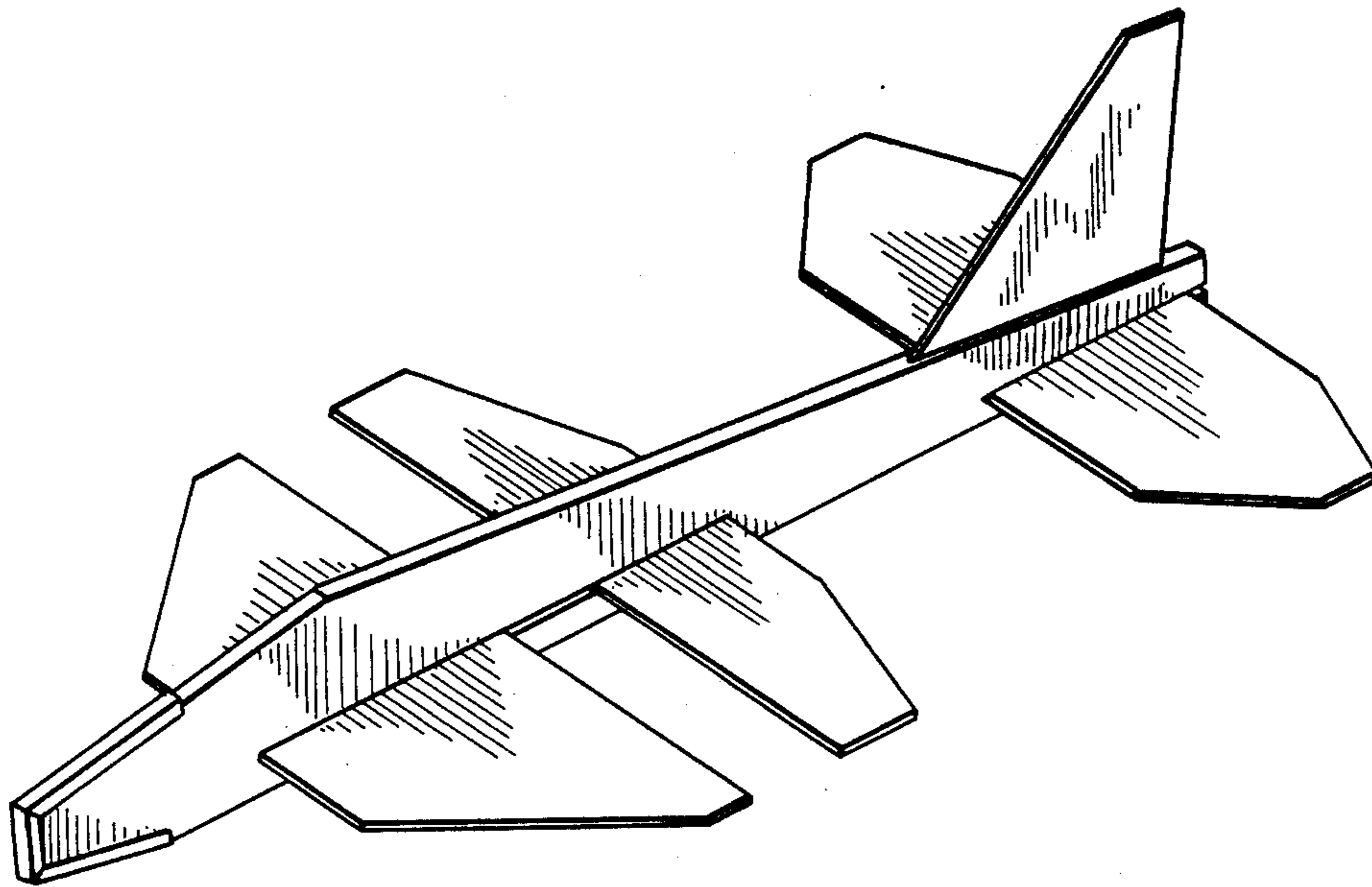

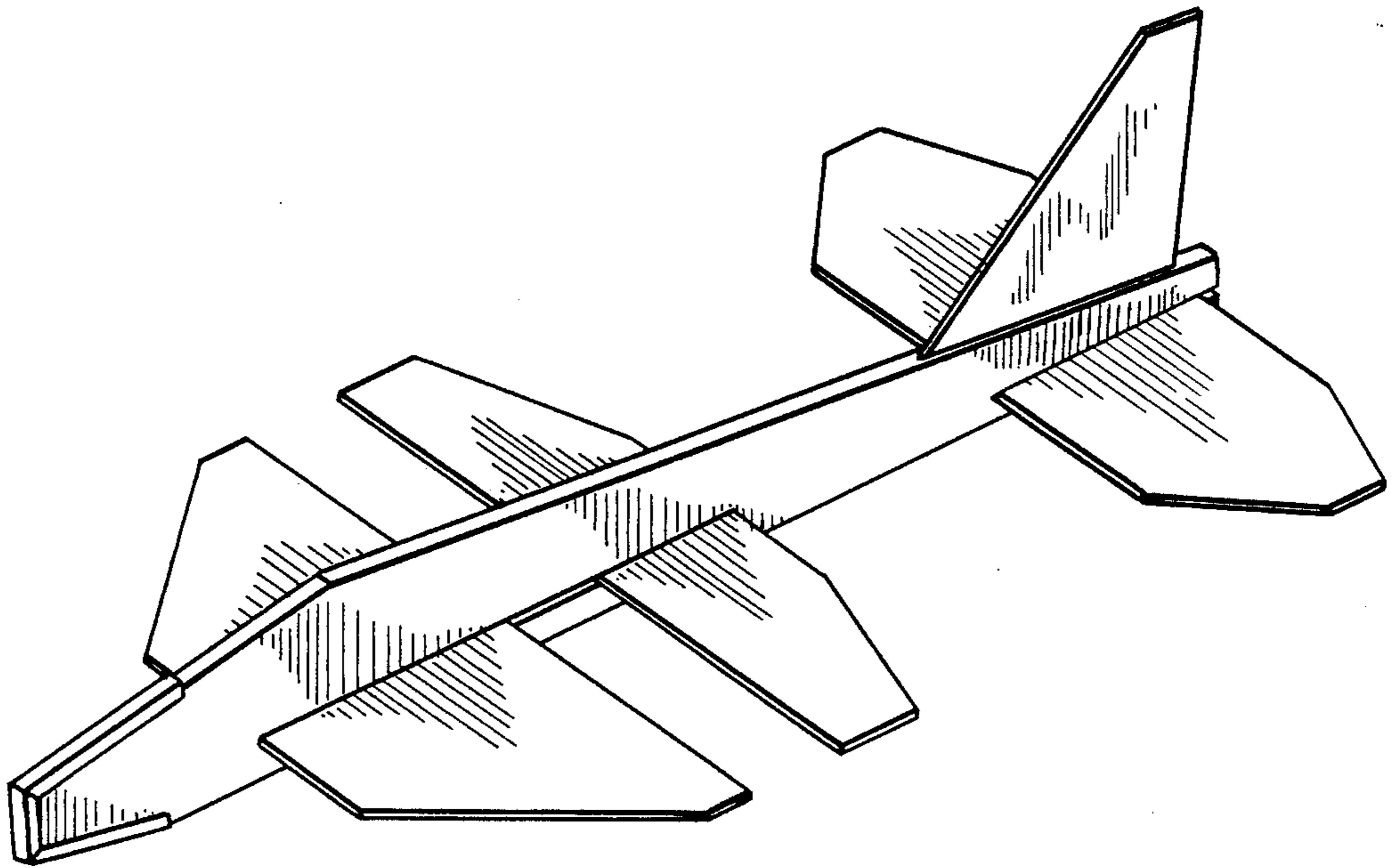

FIG. 1

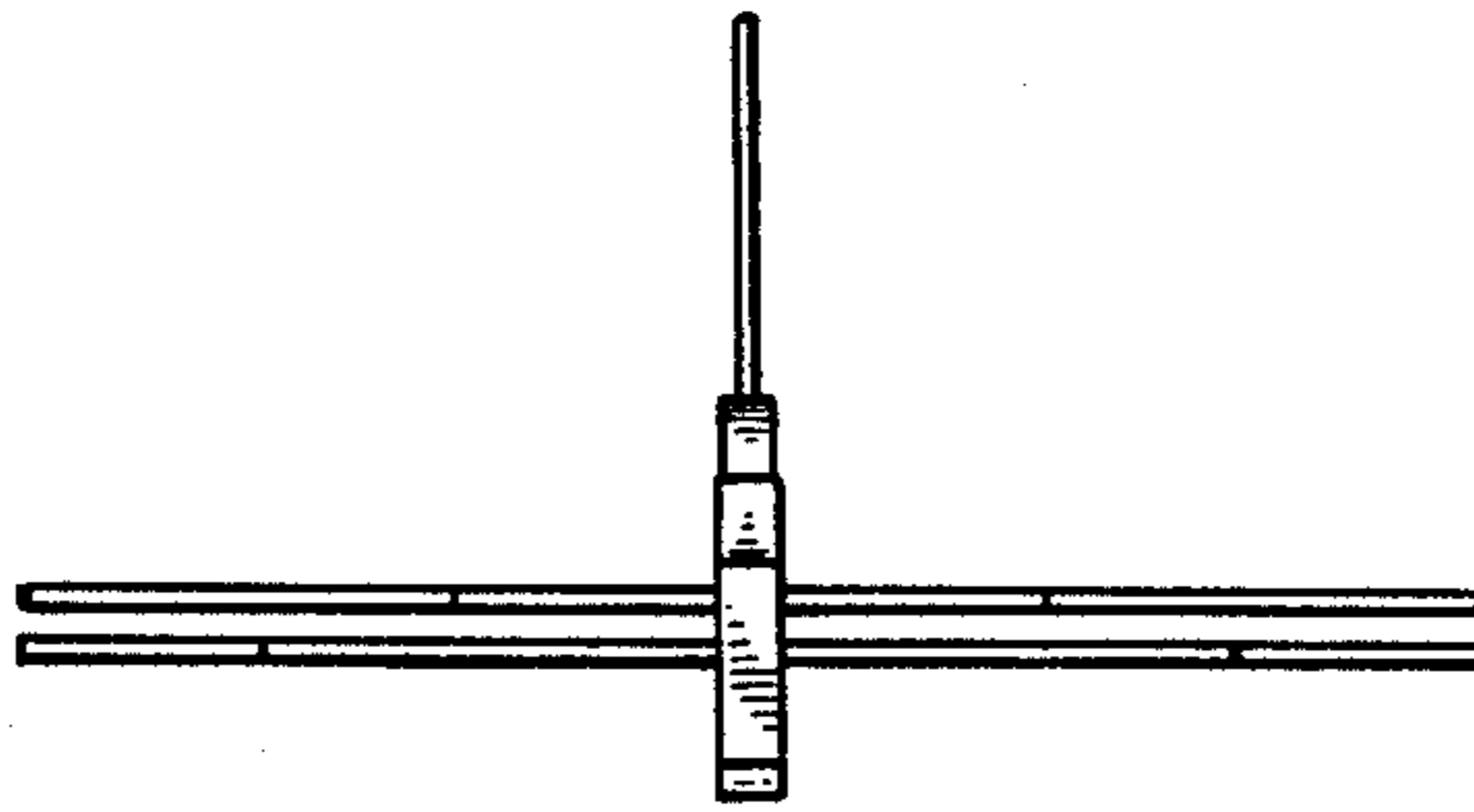

FIG. 2

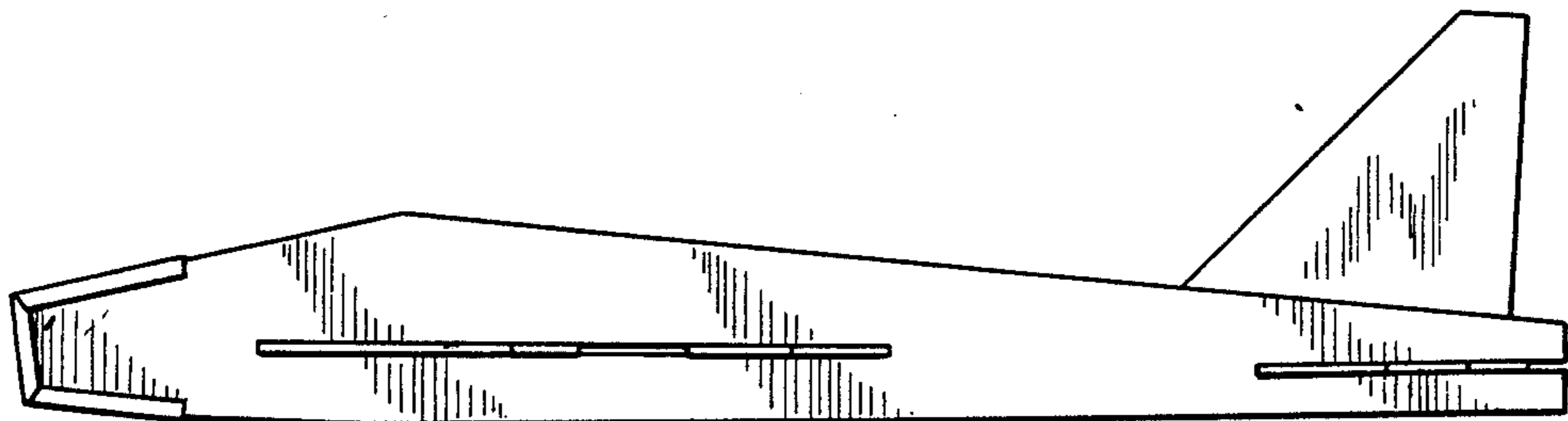

FIG. 3

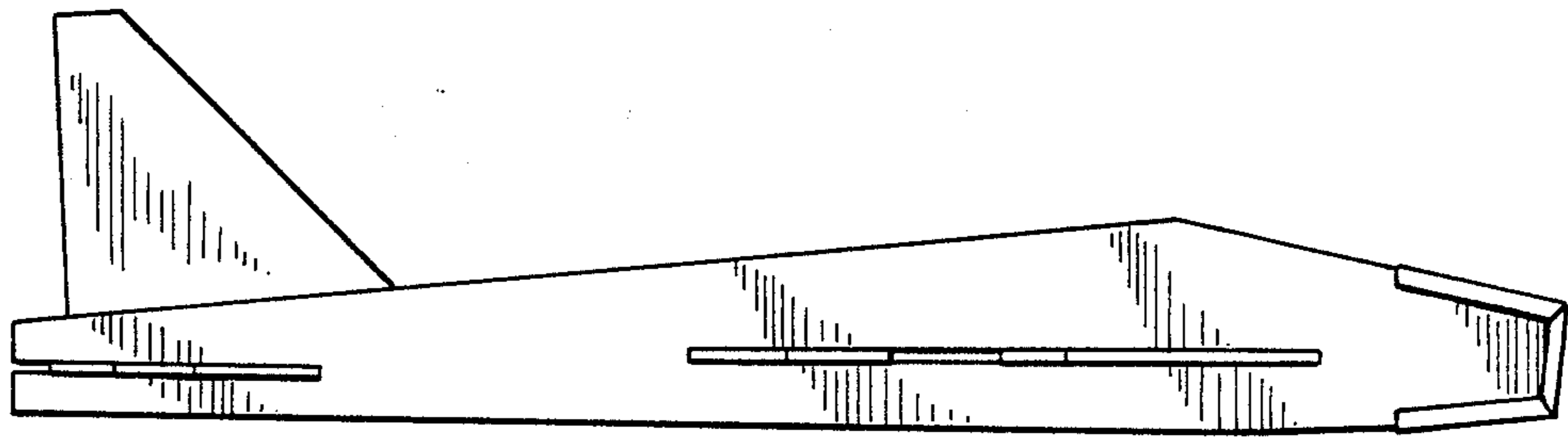

FIG. 4

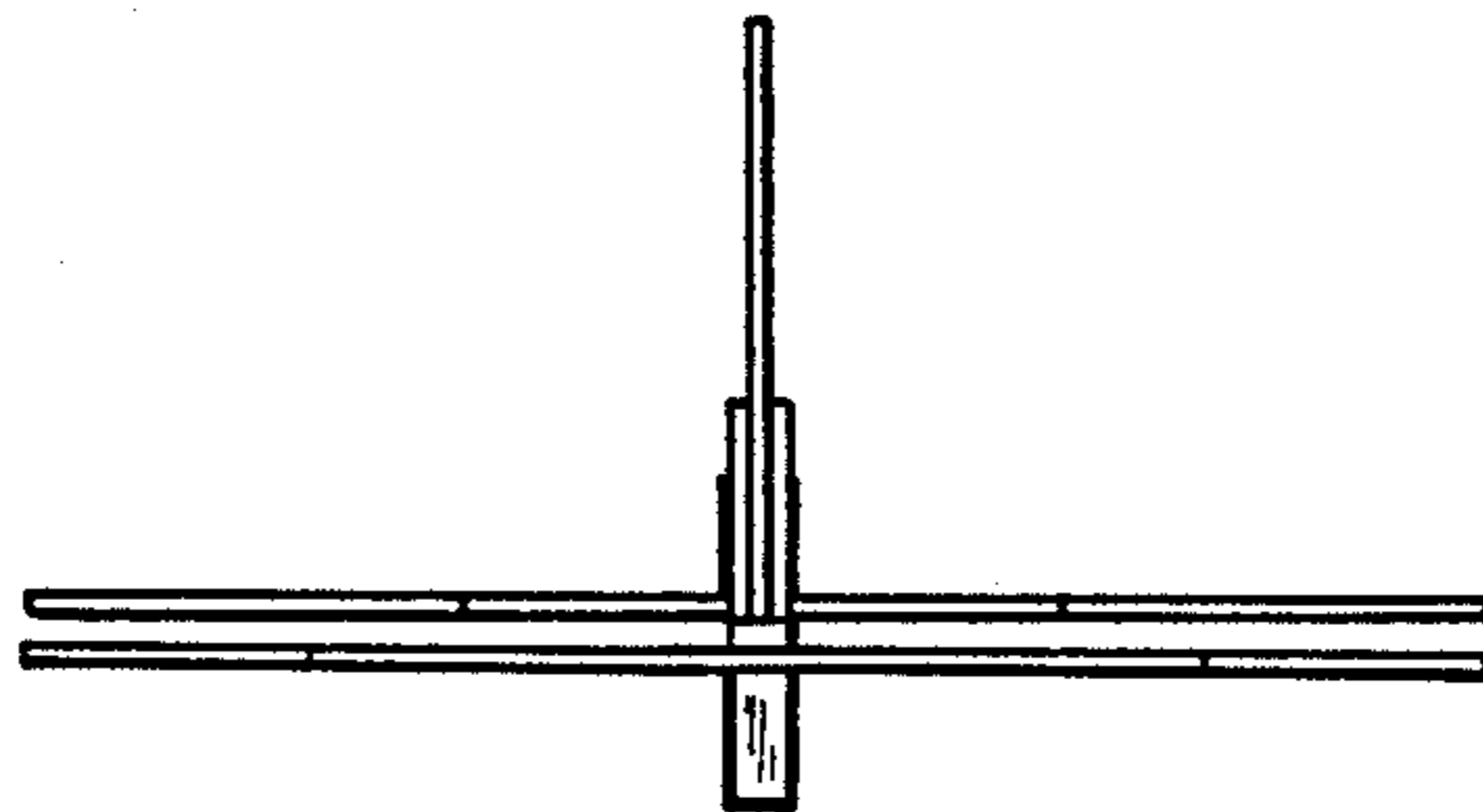

FIG. 5

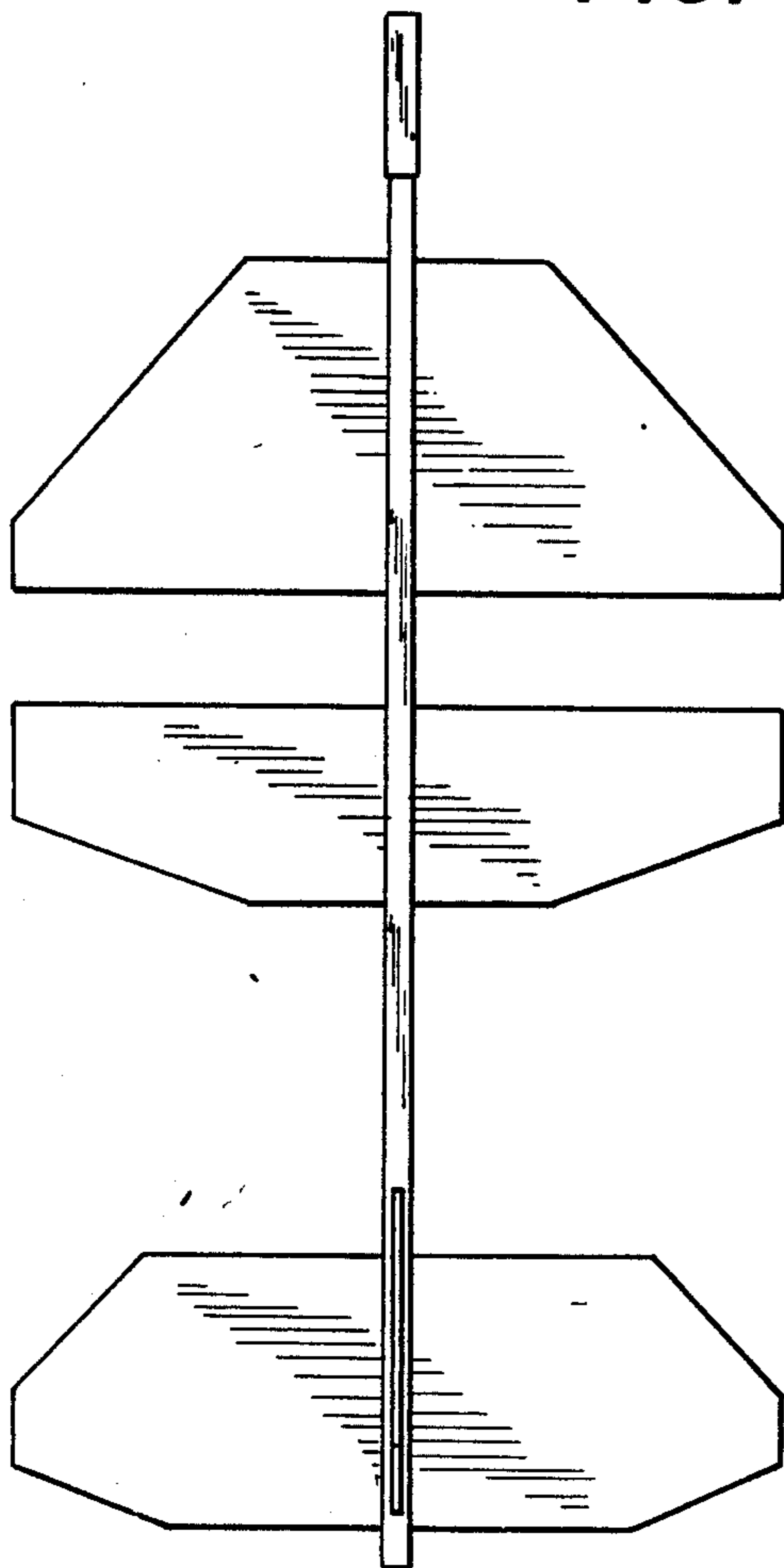

FIG. 6

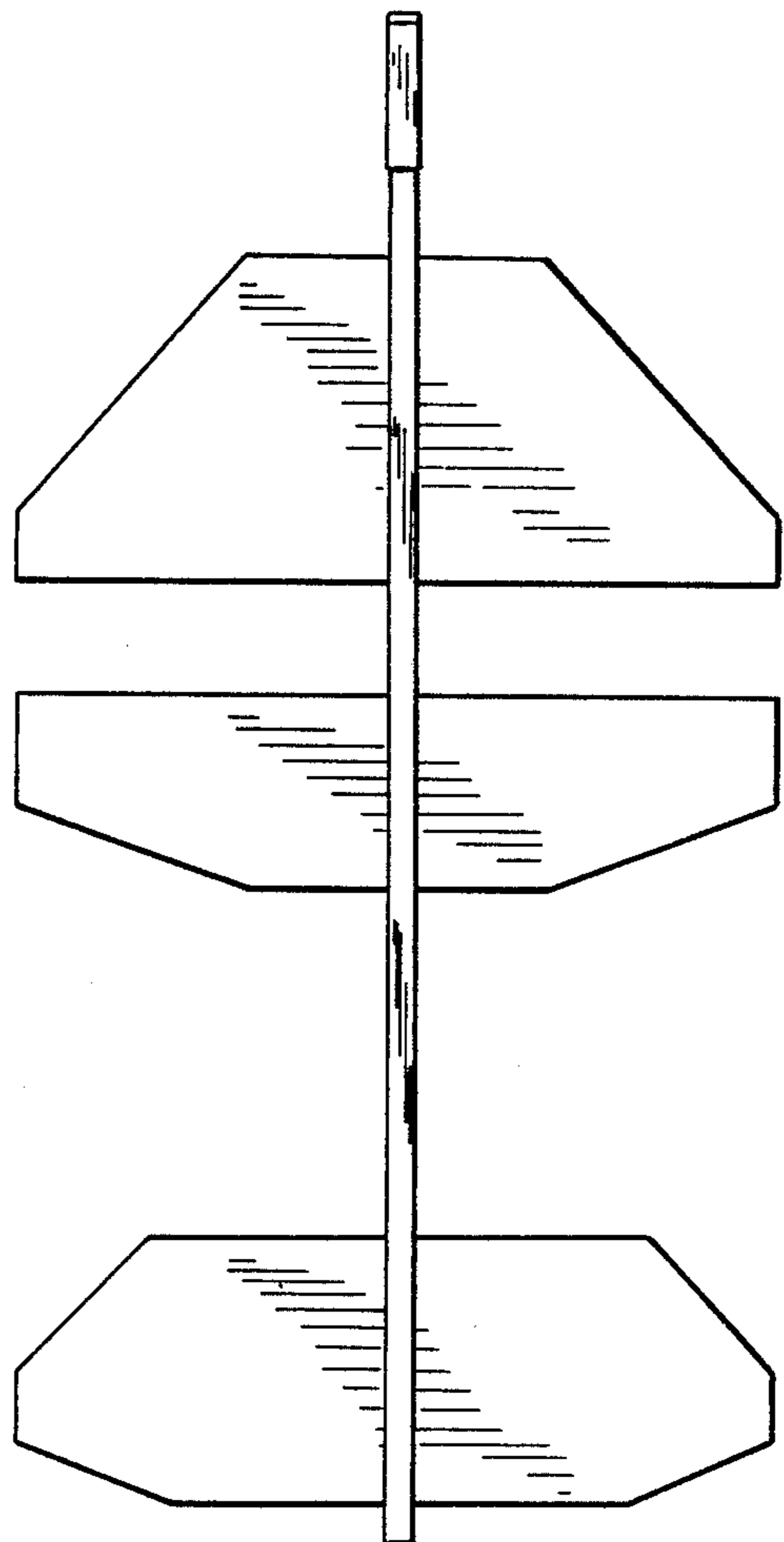

FIG. 7