

[54] WAGON

[76] Inventor: John H. Wagner, 504 Academy, Paragould, Ark. 72450

[**] Term: 14 Years

[21] Appl. No.: 939

[22] Filed: Jan. 2, 1987

[52] U.S. Cl. D21/71

[58] Field of Search D21/71, 73, 74, 76, D21/77, 78, 80; 280/1.12, 1.13, 1.21, 1.22, 87.01, 87.05

[56] References Cited

U.S. PATENT DOCUMENTS

D. 127,563	6/1941	Cloutier	D7/71
D. 136,950	1/1944	Dodson	D21/71
D. 138,193	7/1944	Duffy	D21/134
D. 142,912	11/1945	Silkman	D21/71
D. 235,901	7/1975	Zick	D21/134
D. 277,149	1/1985	Hind	D6/535
288,662	11/1883	Reed	280/87.01
409,682	8/1889	Higham	D21/76
1,639,124	8/1927	Becker	280/87.01
1,728,587	9/1929	Aldridge	D21/71
2,418,971	4/1947	Duffy	280/87.01
2,942,914	6/1960	Noot	D21/71

FOREIGN PATENT DOCUMENTS

433912 9/1926 Fed. Rep. of Germany ... 280/87.01

Primary Examiner—Charles A. Rademaker
Assistant Examiner—Alicia A. Farrell
Attorney, Agent, or Firm—Walker & McKenzie

[57] CLAIM

The ornamental design for a wagon, as shown and described.

DESCRIPTION

FIG. 1 is a side elevational view of a wagon showing my new design, the side opposite being a mirror image thereof;
FIG. 2 is a rear elevational view thereof;
FIG. 3 is a front elevational view thereof;
FIG. 4 is a top plan view thereof;
FIG. 5 is a bottom plan view thereof;
FIG. 6 is a perspective view thereof;
FIG. 7 is a perspective view of a modified embodiment of the design shown in FIGS. 1 through 6;
FIG. 8 is a side elevational view thereof, the side opposite being a mirror image;
FIG. 9 is a rear elevational view thereof;
FIG. 10 is a front elevational view thereof;
FIG. 11 is a top plan view thereof; and
FIG. 12 is a bottom plan view thereof.

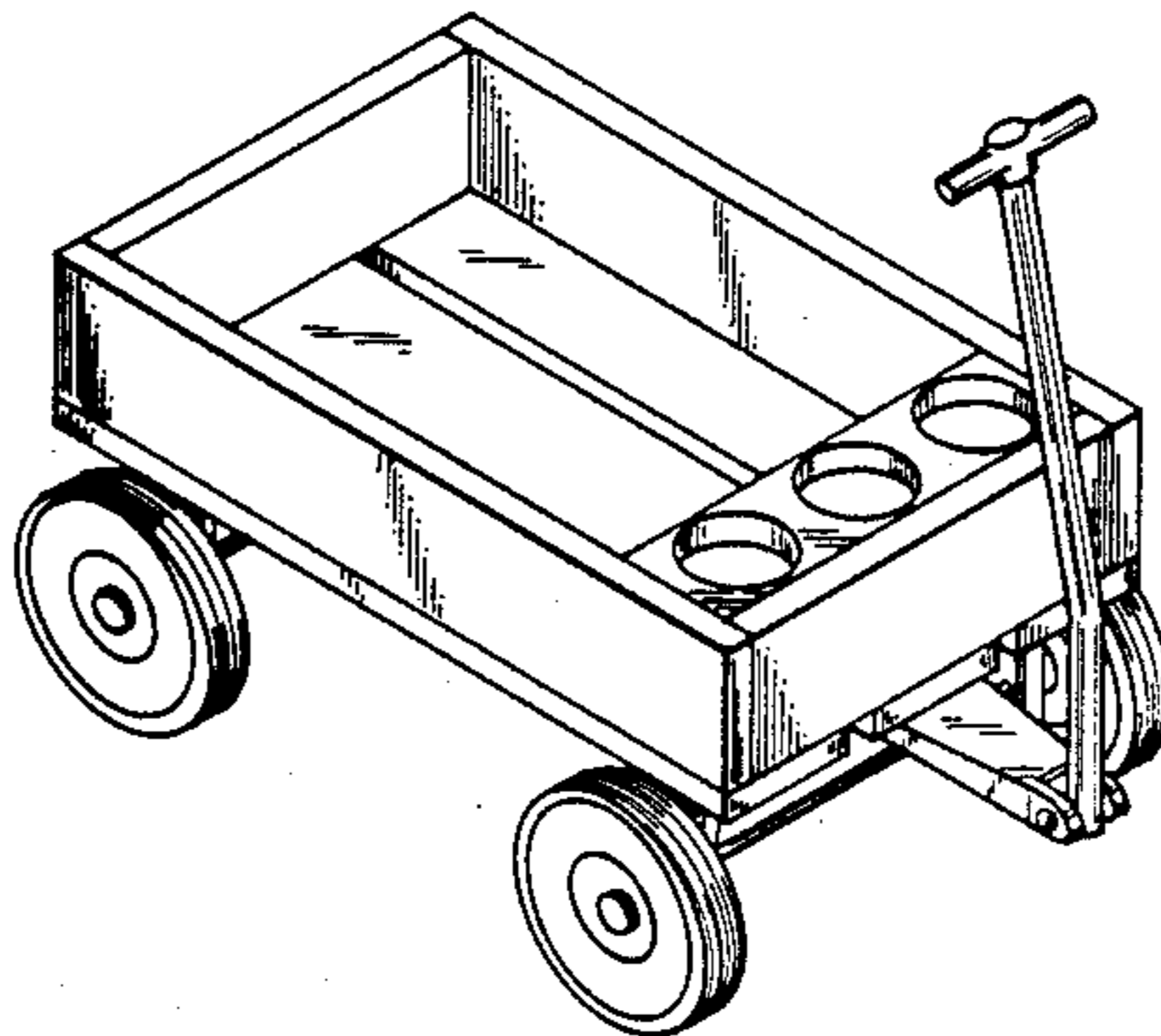
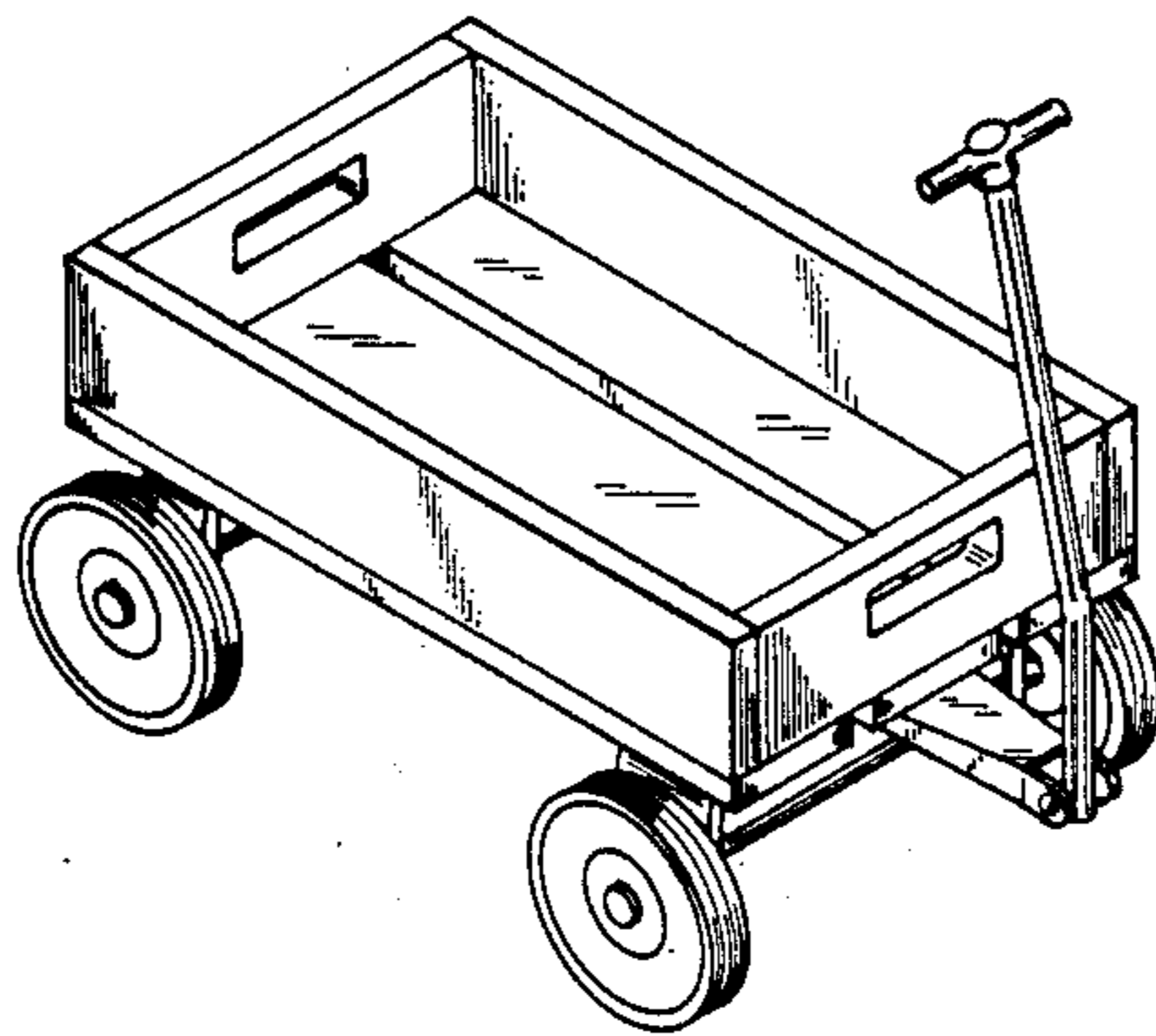

FIG. 1

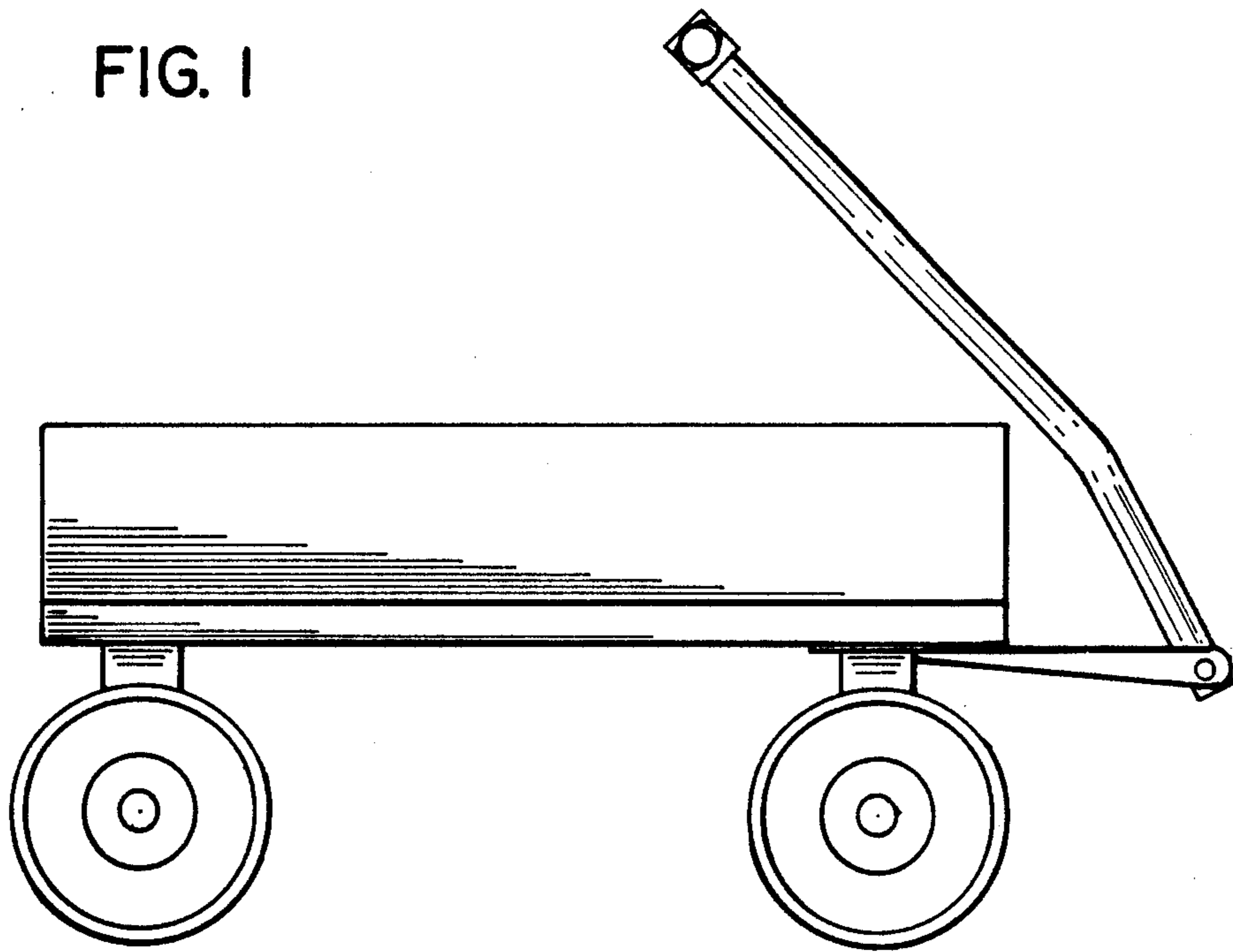

FIG. 2

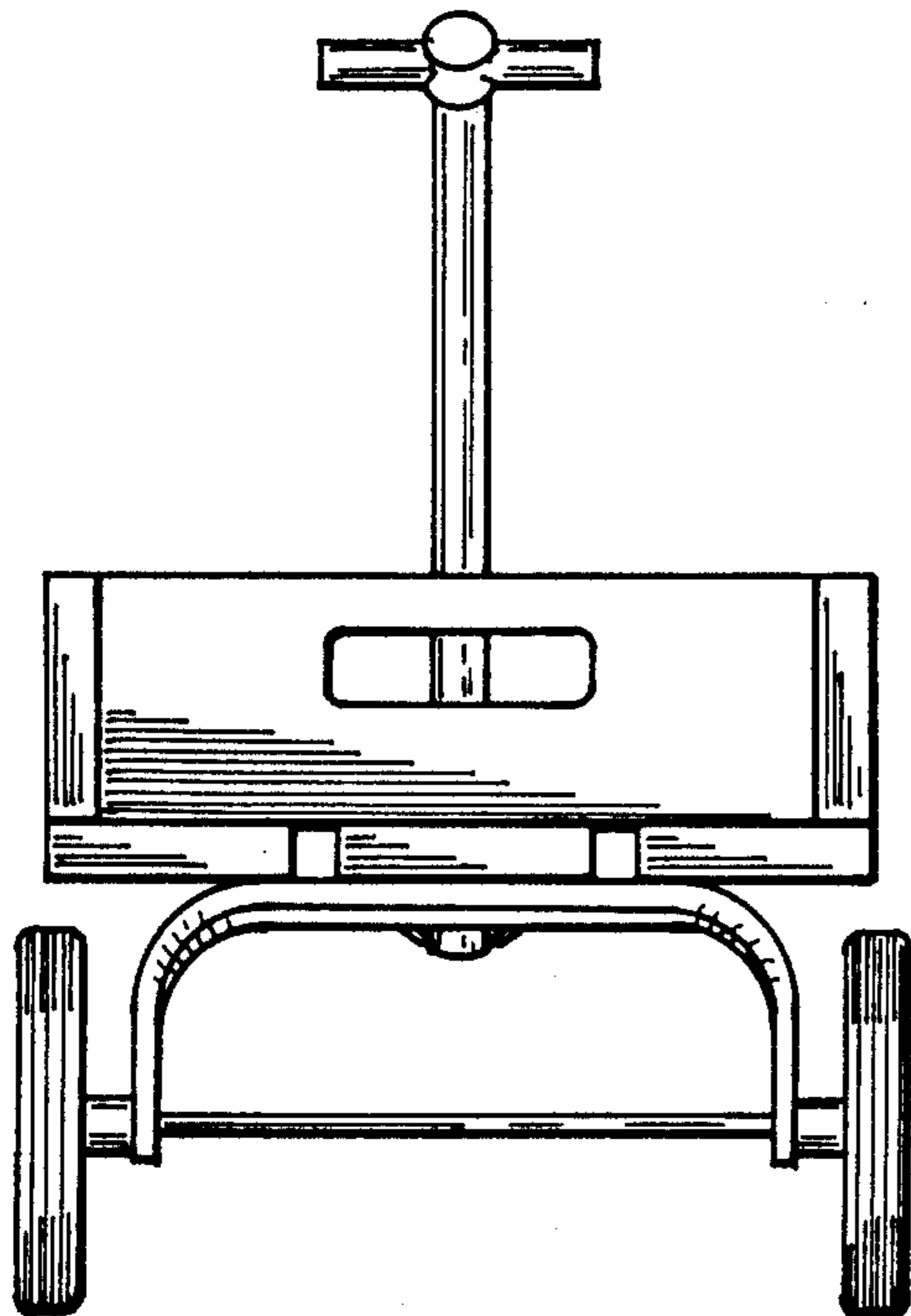

FIG. 3

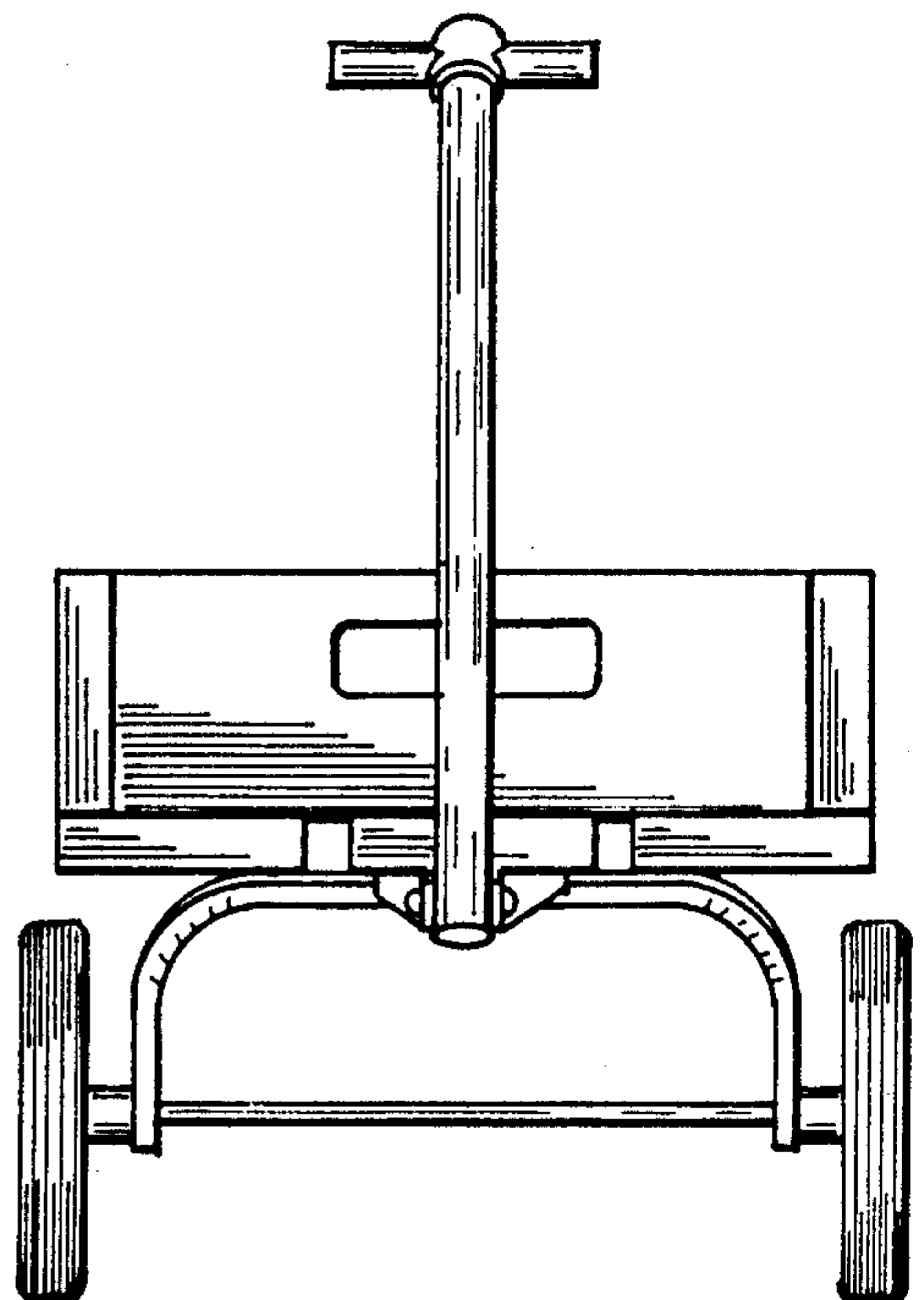

FIG. 4

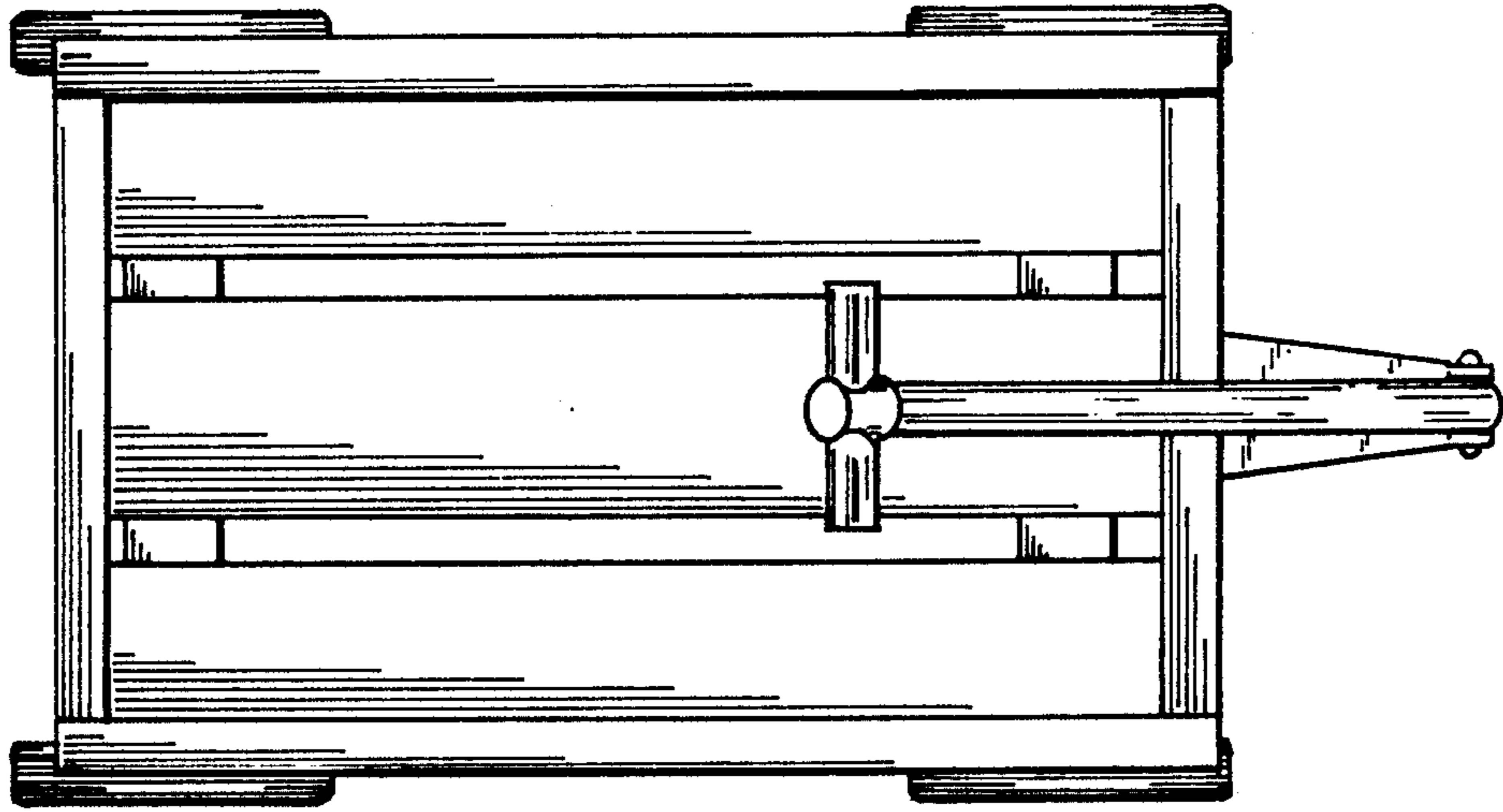

FIG. 5

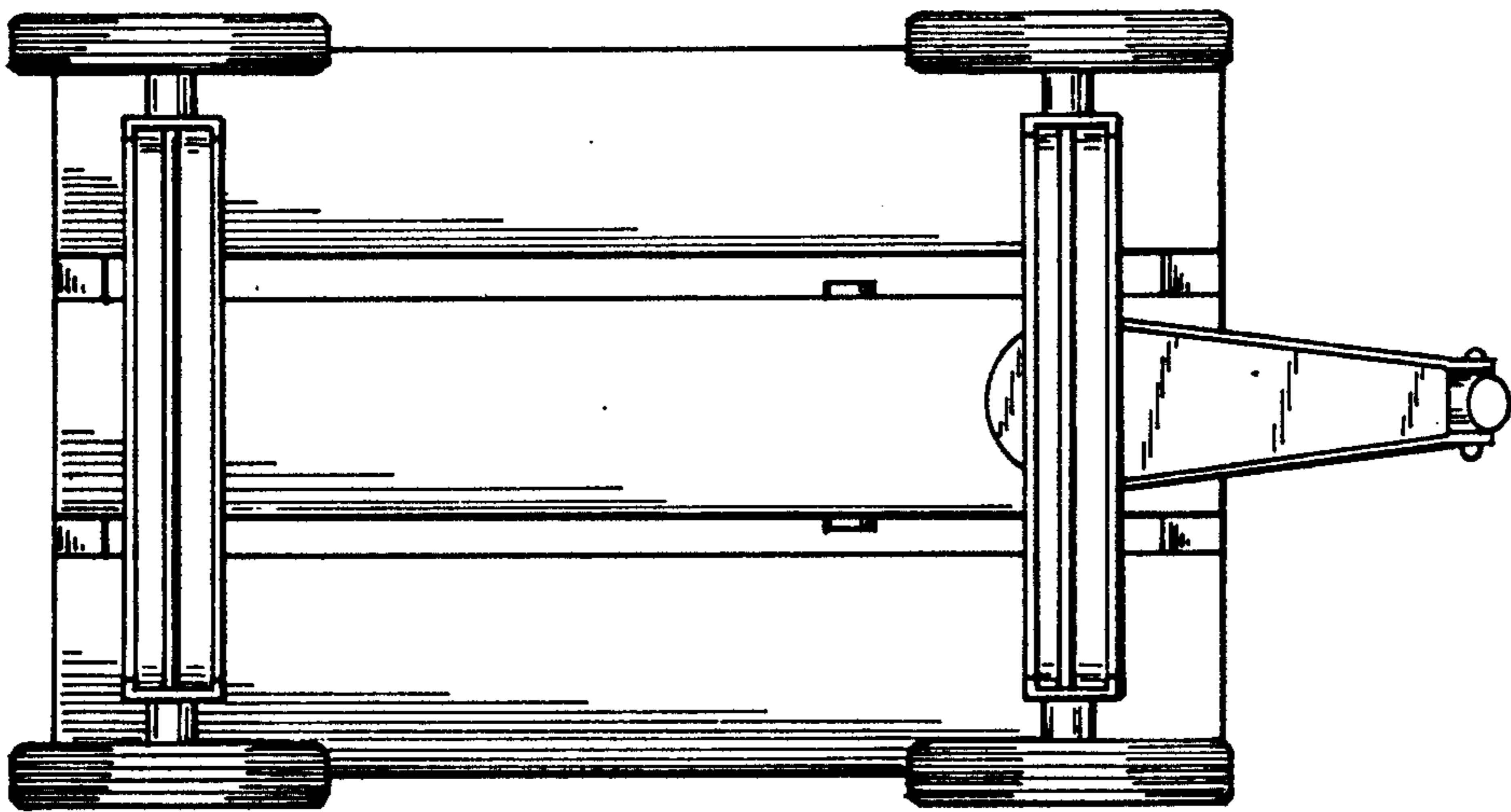

FIG. 6

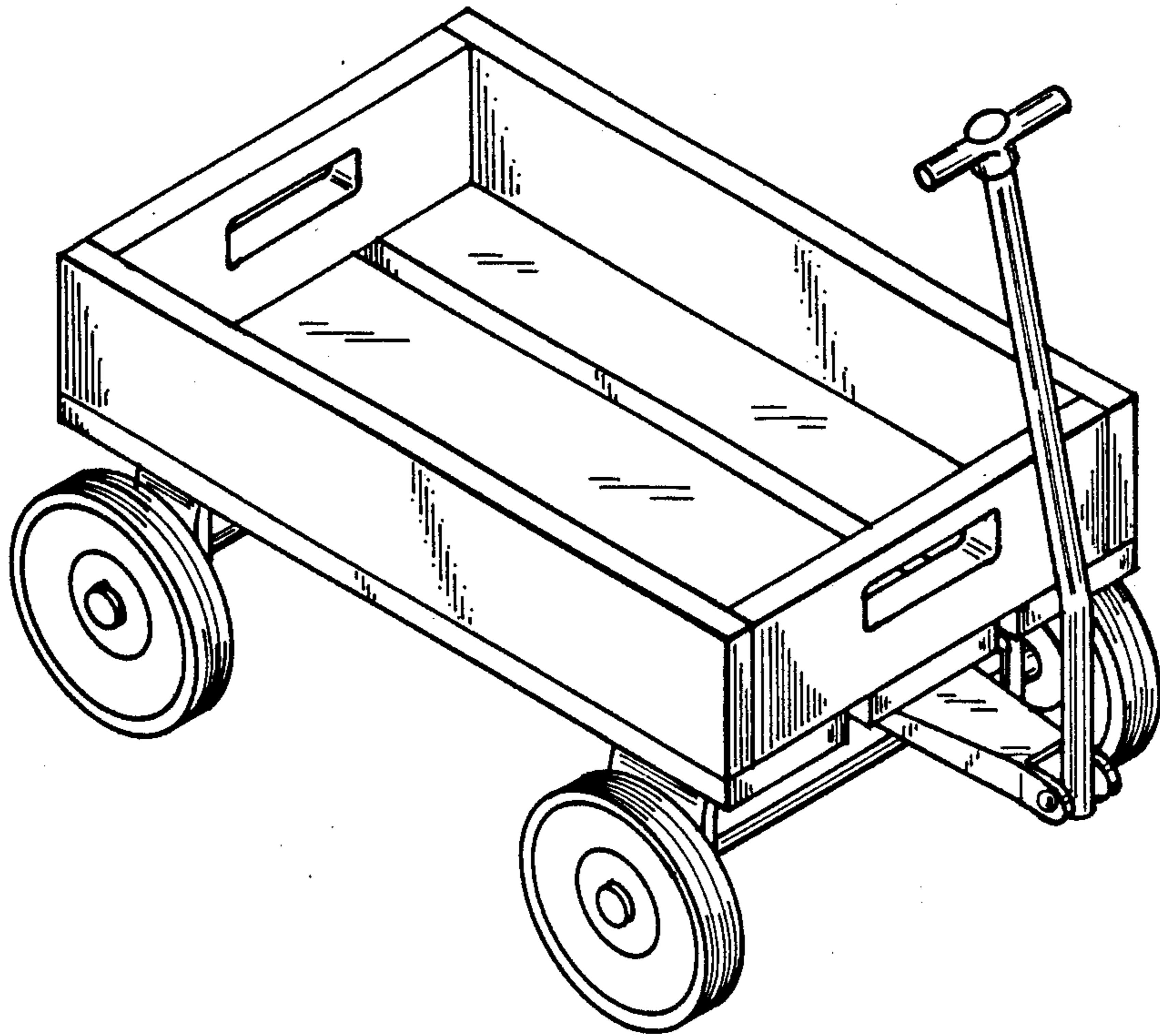

FIG. 7

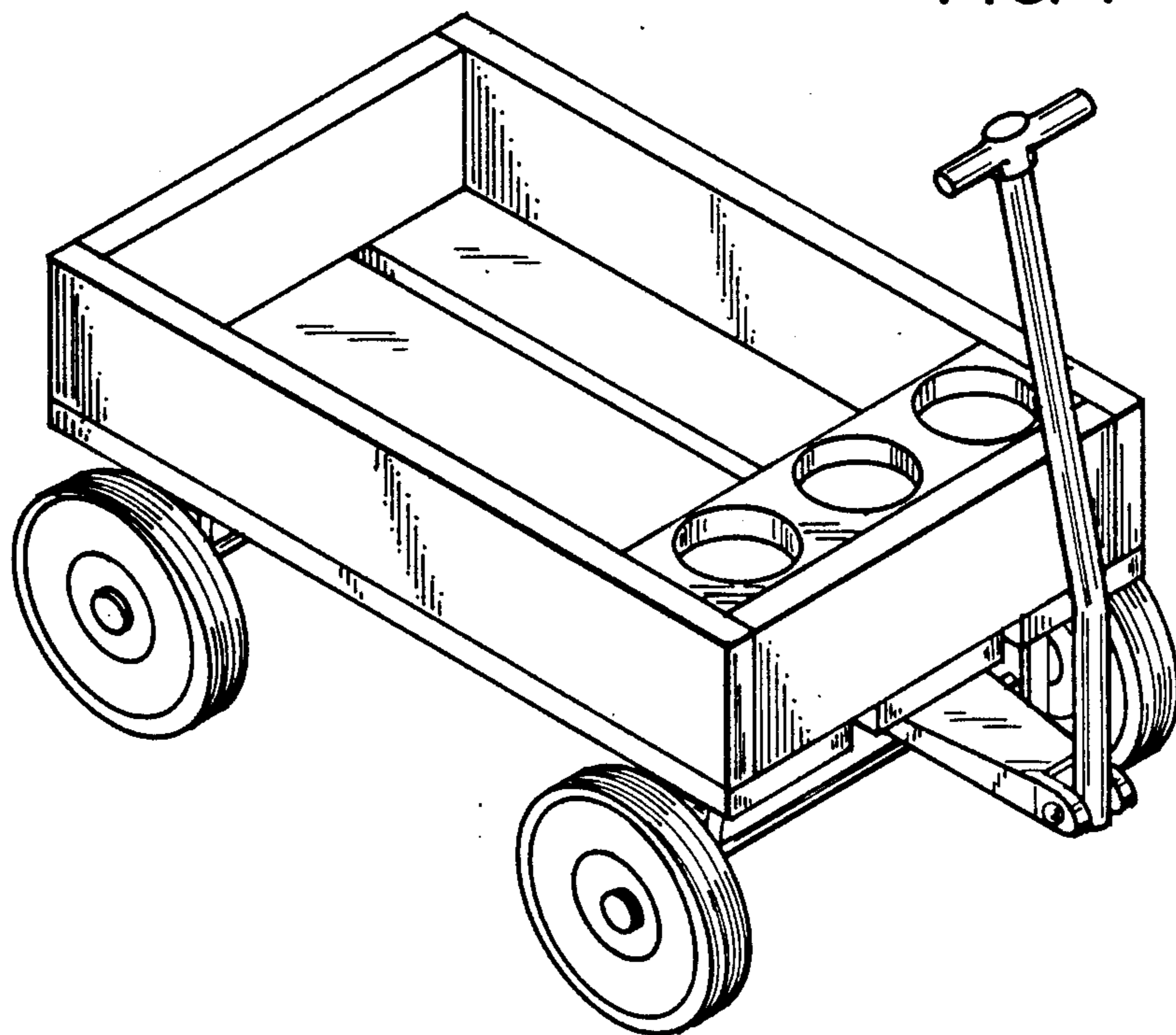

FIG. 8

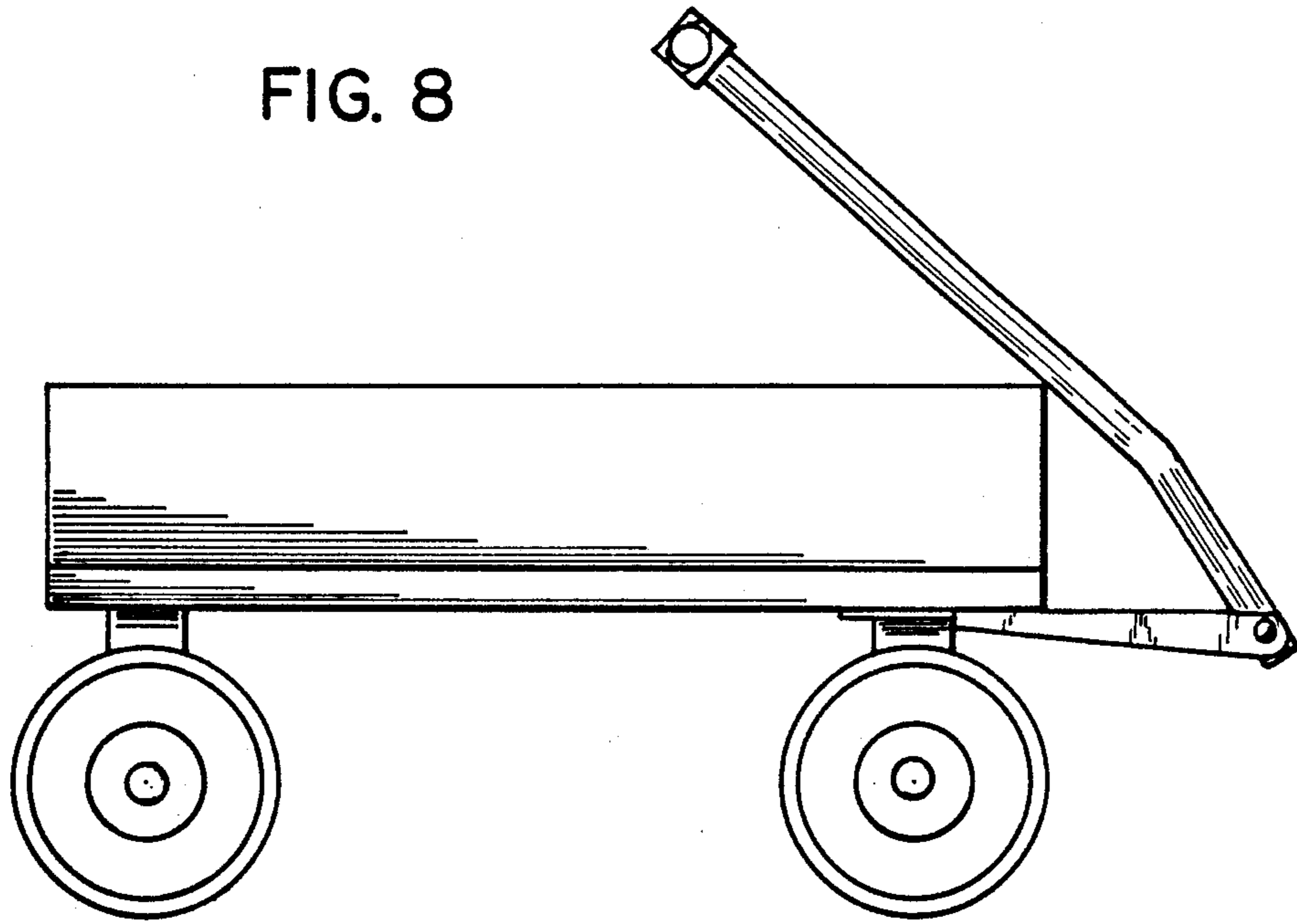

FIG. 9

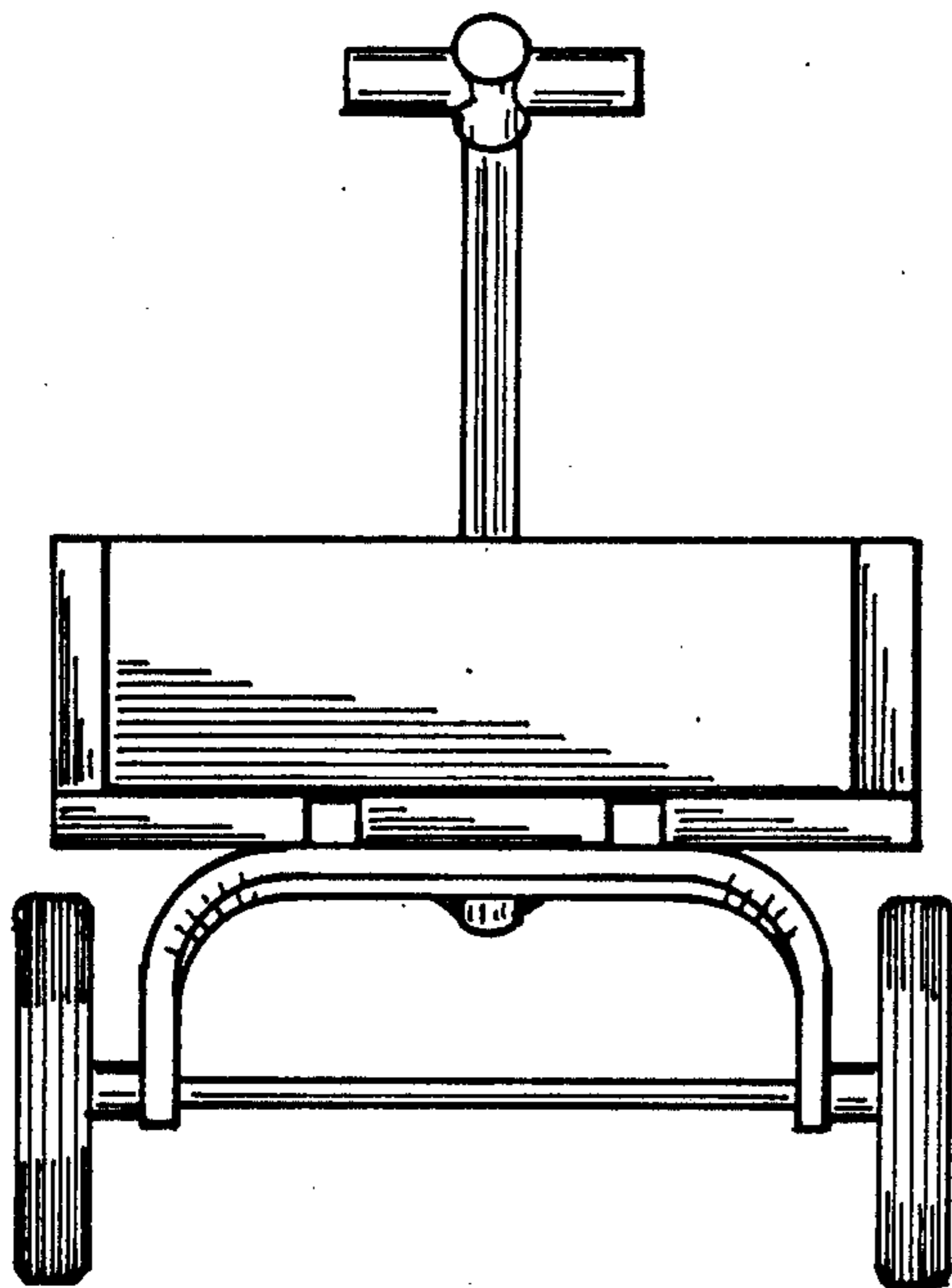

FIG. 10

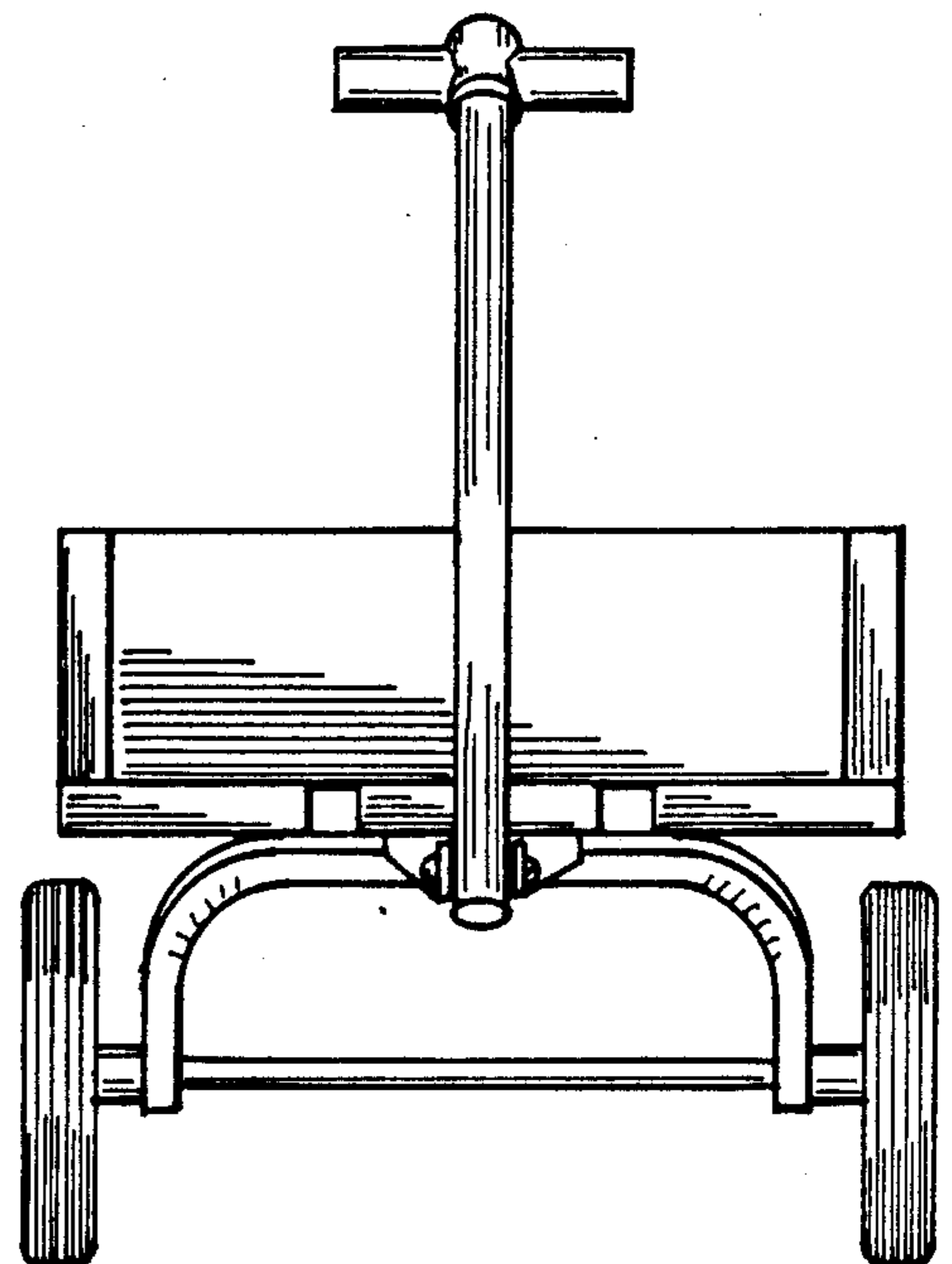

FIG. 11

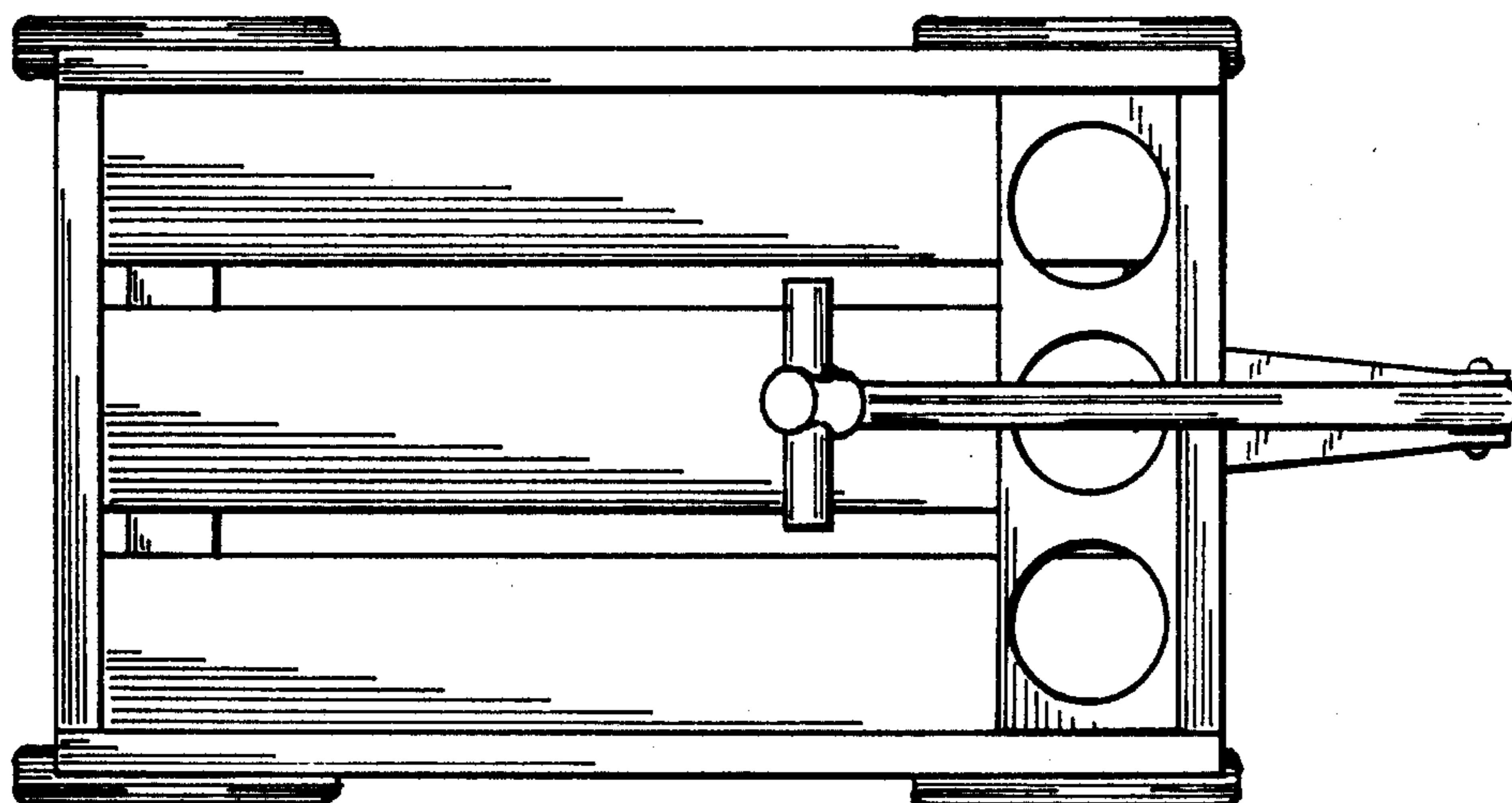

FIG. 12

