

[54] COMBINED VEHICLE FRONT BUMPER AND GUARD

D. 300,128 3/1989 Brennan D12/169

[75] Inventor: Gibson Bennie, Houston, Tex.

Primary Examiner—James M. Gandy
Attorney, Agent, or Firm—Edward A. Sokolski

[73] Assignee: Aussie Bull Bars, Inc., Houston, Tex.

[57] CLAIM

[**] Term: 14 Years

The ornamental design for a combined vehicle front bumper and guard, as shown and described.

[21] Appl. No.: 114,533

DESCRIPTION

[22] Filed: Oct. 26, 1987

[52] U.S. Cl. D12/169; D12/171

[58] Field of Search D12/169, 171, 167;
293/102, 112, 115, 143, 146

FIG. 1 is a front perspective view showing my new design for a combined vehicle front bumper and guard; FIG. 2 is a rear elevational view thereof; FIG. 3 is a top plan view thereof; FIG. 4 is a bottom plan view thereof; and FIG. 5 is an end elevational view thereof; The end opposite that shown in FIG. 5 is the mirror image thereof.

[56] References Cited

U.S. PATENT DOCUMENTS

- D. 148,980 3/1948 Bustin D12/171
- D. 248,229 6/1978 Baker D12/169
- D. 258,502 3/1981 Nespor D12/169

The broken lines in FIG. 1 are for illustrative purposes only and form no part of the claimed design.

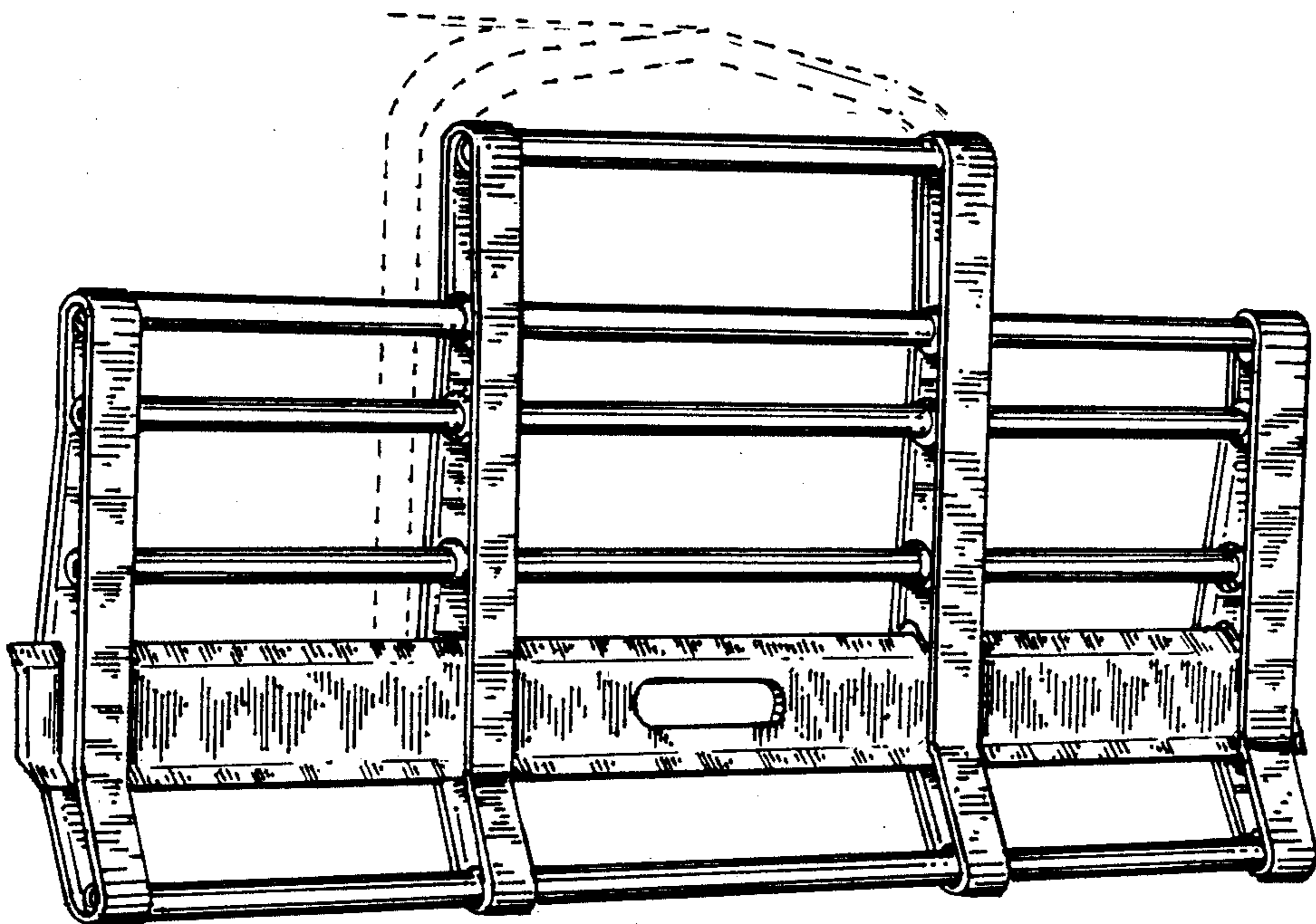

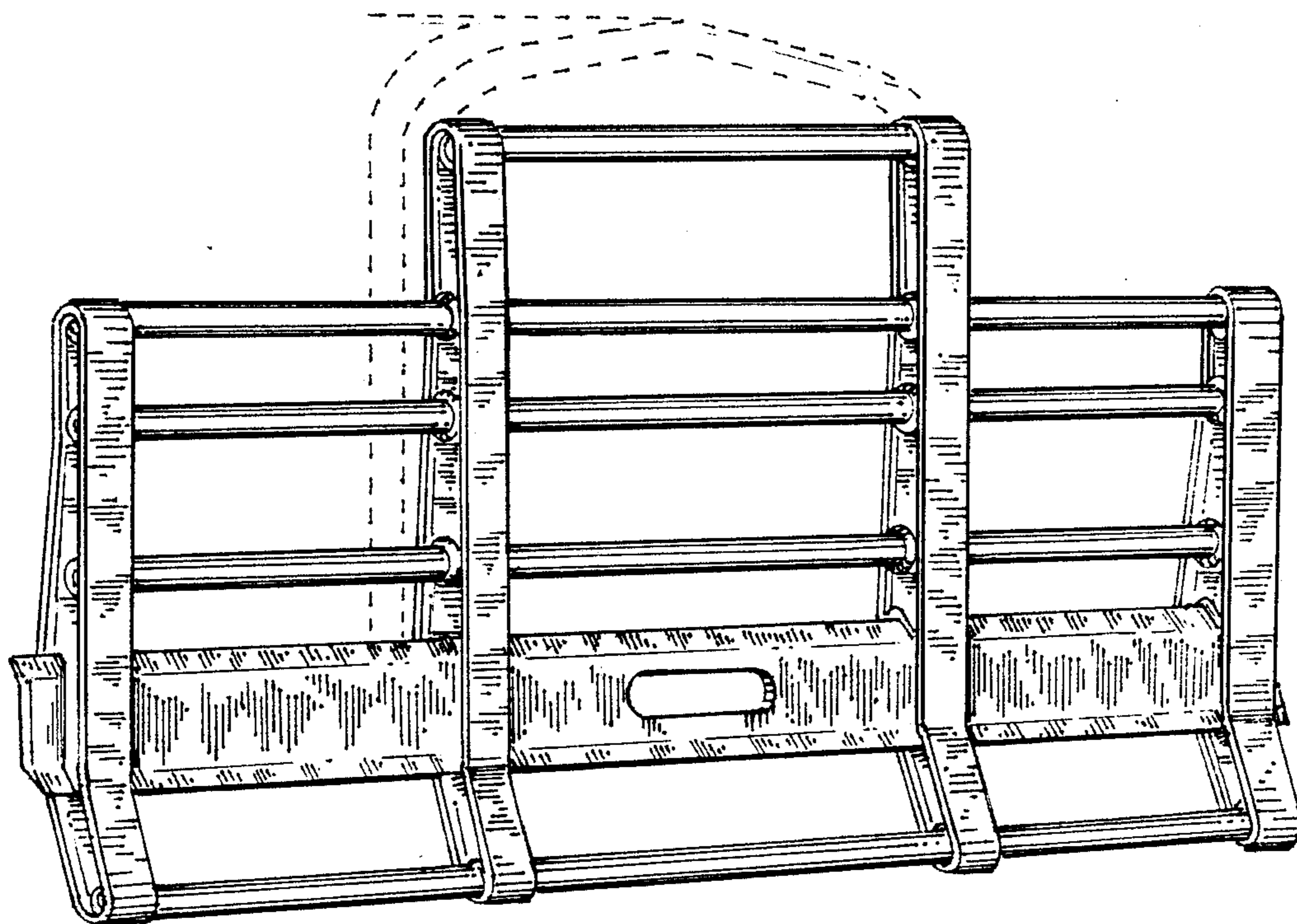

FIG. 1

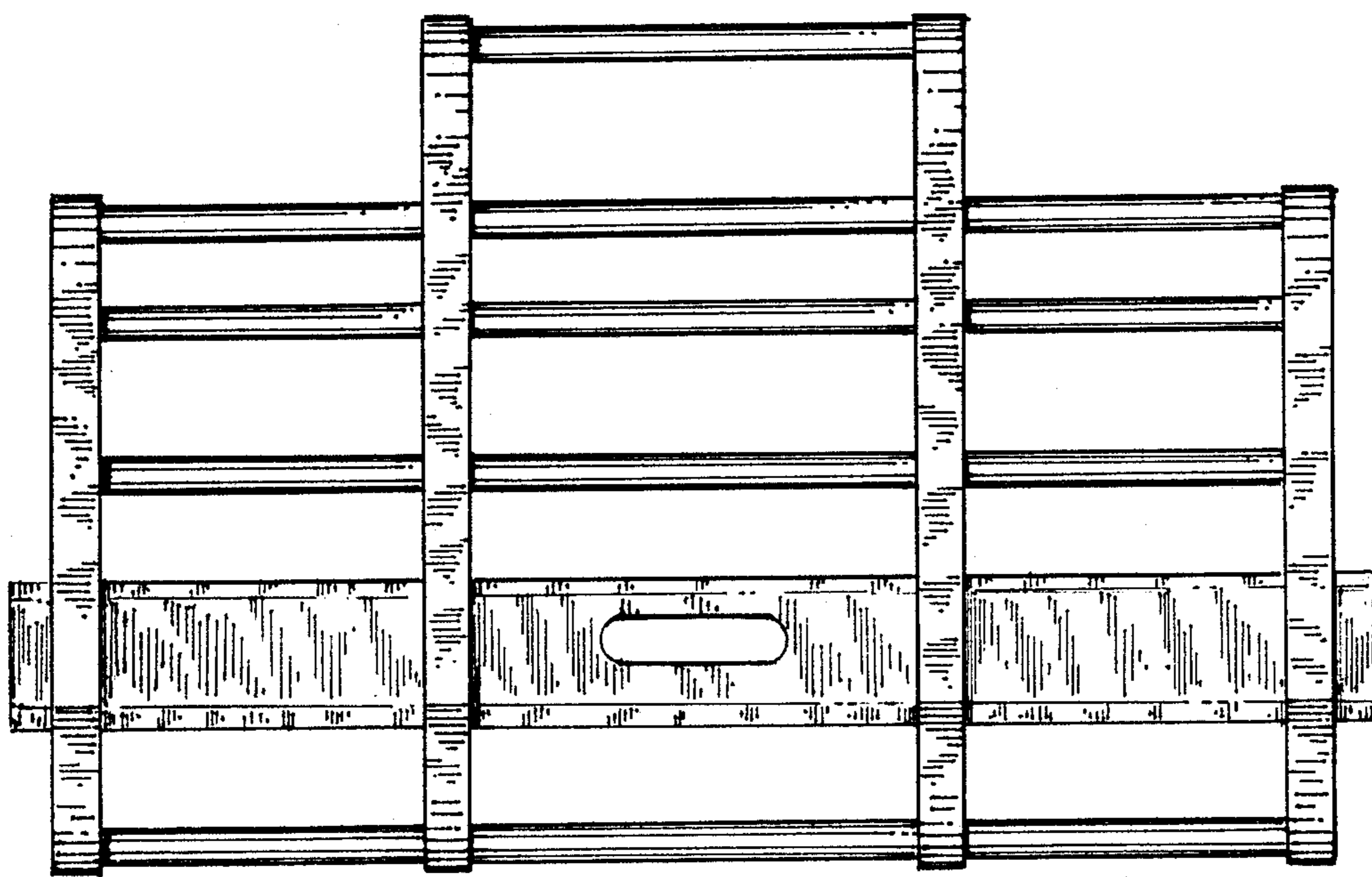

FIG. 2

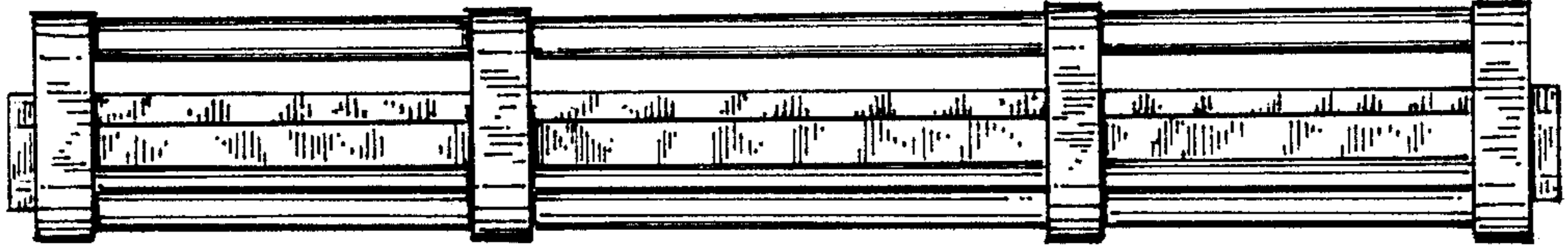

Fig. 3

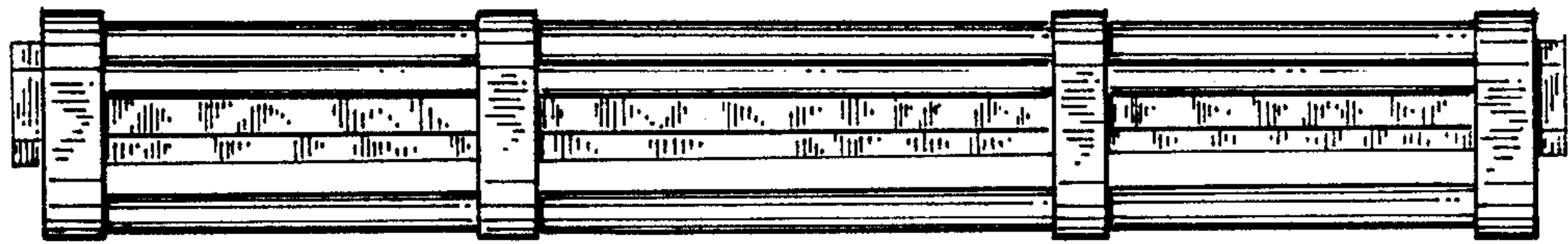

Fig. 4

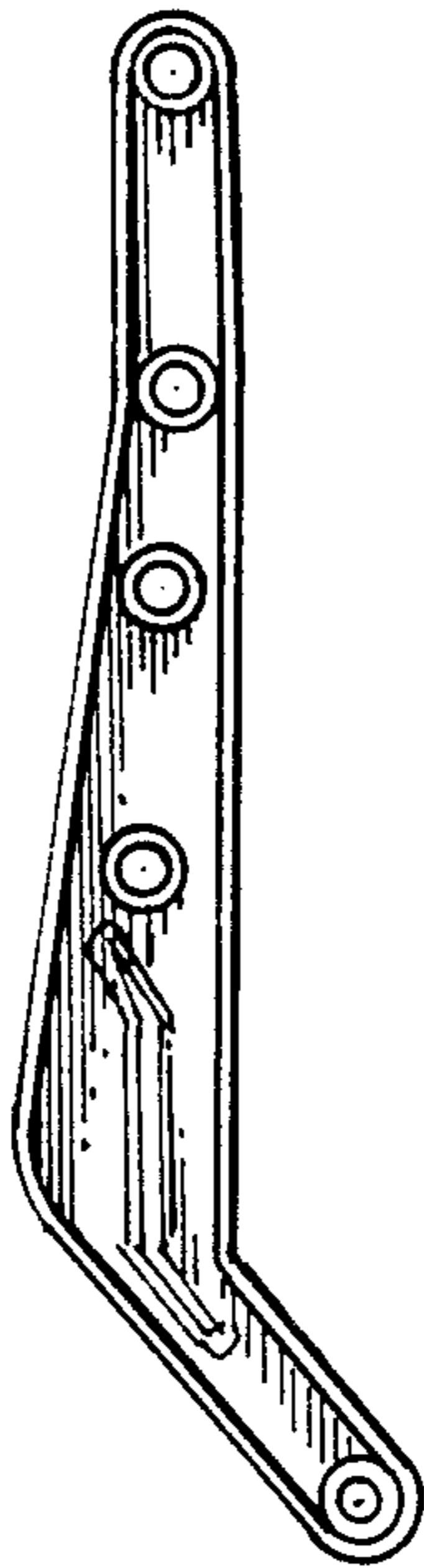

Fig. 5