

[54] FLASHLIGHT HOLDER CLAMP ASSEMBLY

[75] Inventors: Anthony Maglica, Ontario; Armis L. Lewis, Cucamonga, both of Calif.

[73] Assignee: Mag Instrument, Inc., Ontario, Calif.

[**] Term: 14 Years

[21] Appl. No.: 285,803

[22] Filed: Dec. 16, 1988

[52] U.S. Cl. D26/138; D8/396; D26/140

[58] Field of Search D26/138, 139, 140; D8/349; 373/354; 355/394, 395, 396; 248/225.1, 225.31, 231.7, 229, 231, 228, 205, 74.2, 67.5

[56] References Cited

U.S. PATENT DOCUMENTS

- D. 252,443 7/1979 De Giorgis D8/373
- D. 279,612 7/1985 Bacevius D26/138

- 4,365,778 12/1982 Joussemet 248/229
- 4,477,865 10/1984 Tsuyama 362/72 X
- 4,595,163 6/1986 Guggiari 248/229

Primary Examiner—Susan J. Lucas
Attorney, Agent, or Firm—Lyon & Lyon

[57] CLAIM

The ornamental design for flashlight holder clamp assembly, as shown and described.

DESCRIPTION

FIG. 1 is an exploded top, front, left side perspective view of a flashlight holder clamp assembly showing our new design;

FIG. 2 is a top, front, left side perspective view thereof;

FIG. 3 is a front elevational view thereof, the rear being a mirror image;

FIG. 4 is a side elevational view thereof, the opposite side being a mirror image;

FIG. 5 is a top plan view thereof;

FIG. 6 is a bottom plan view thereof.

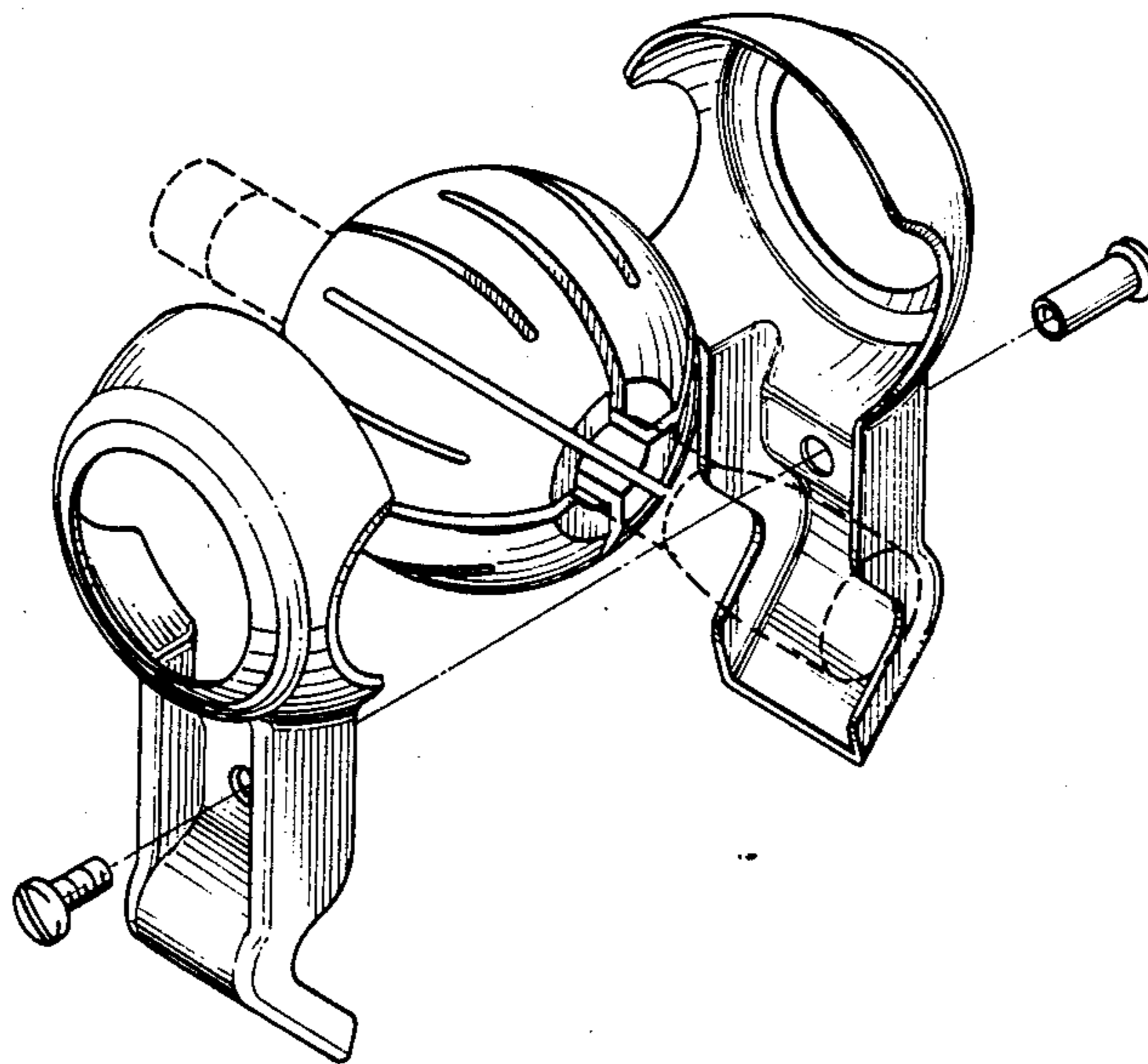

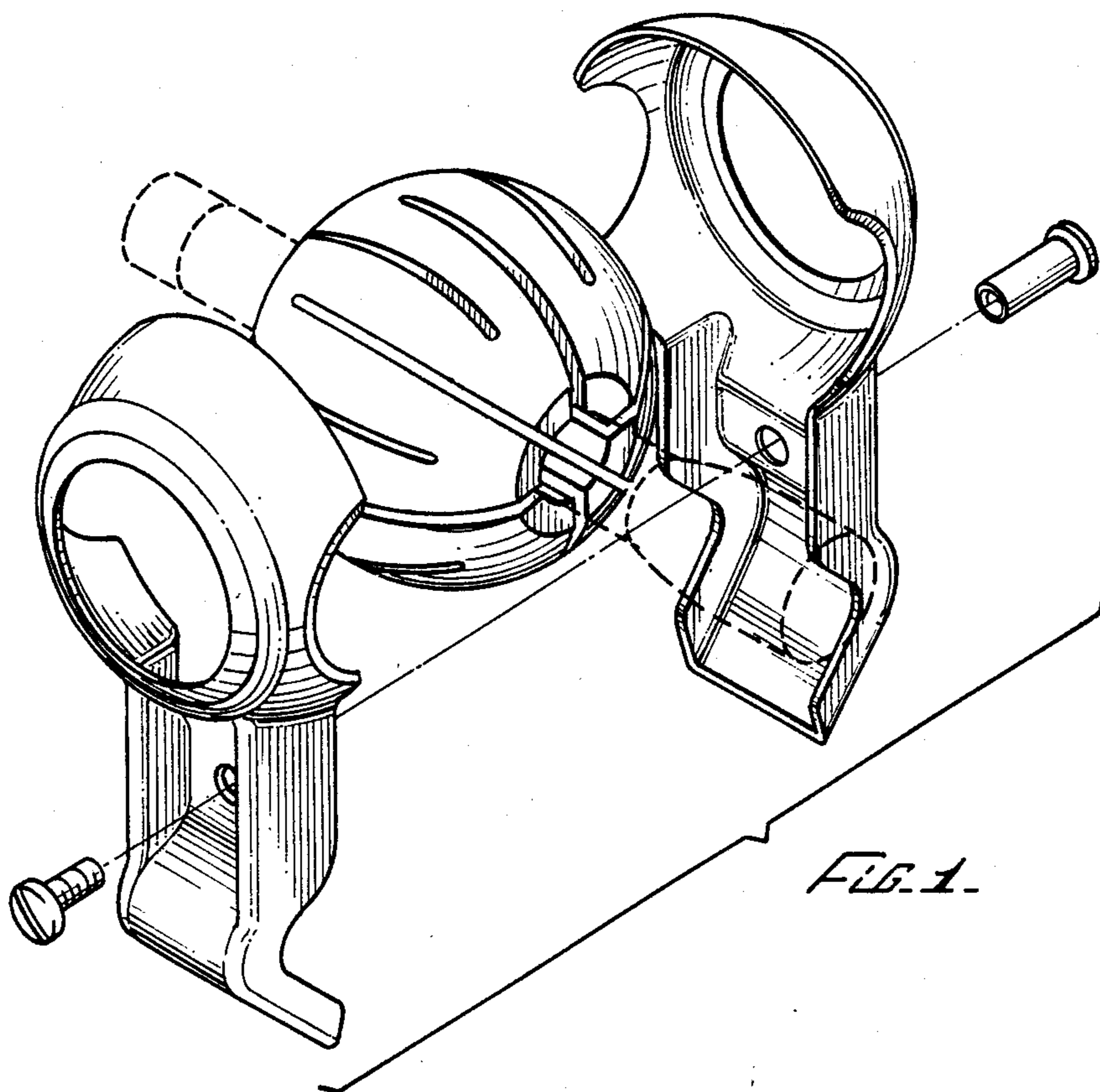

FIG. 1.

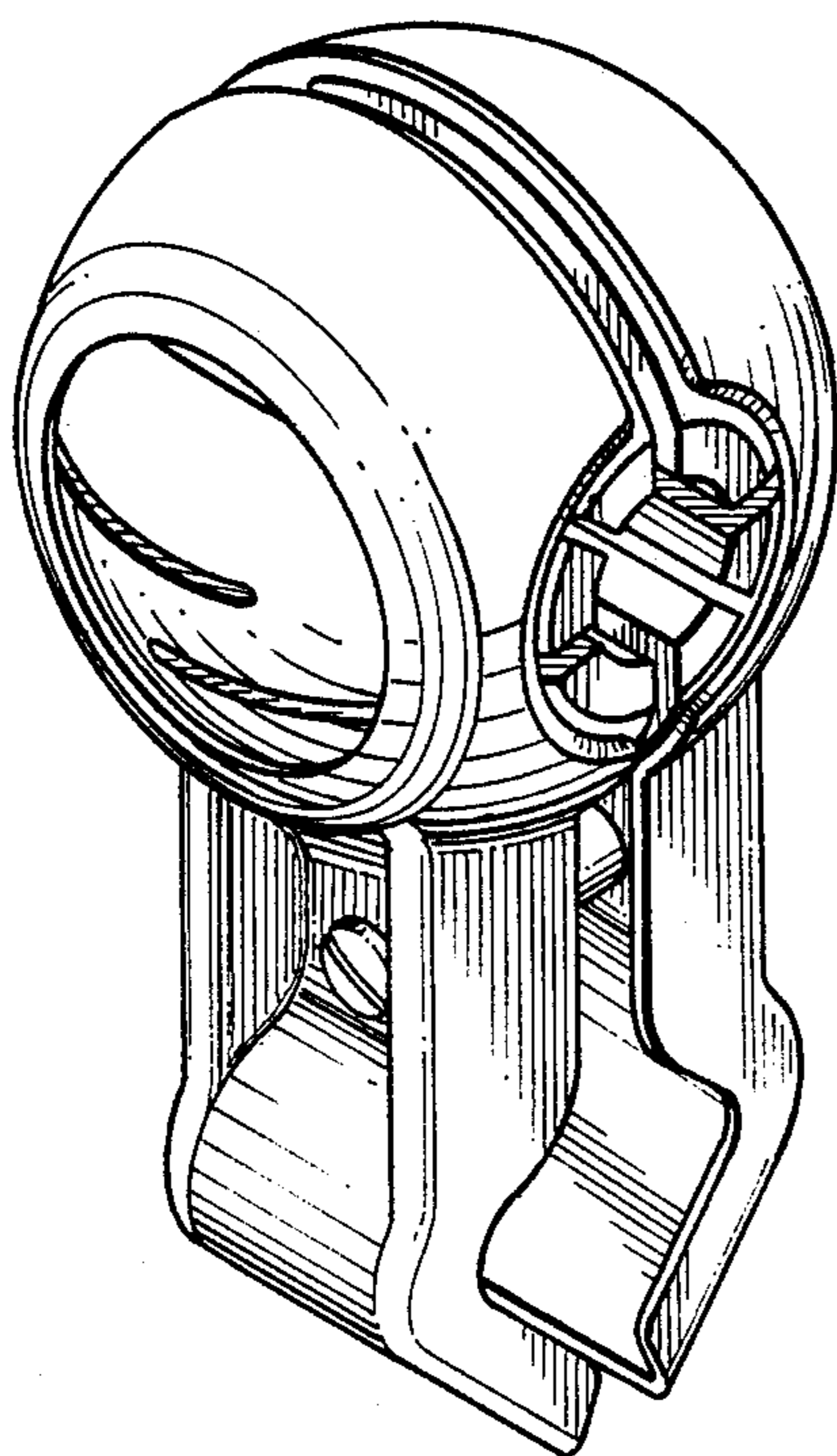

FIG. 2.

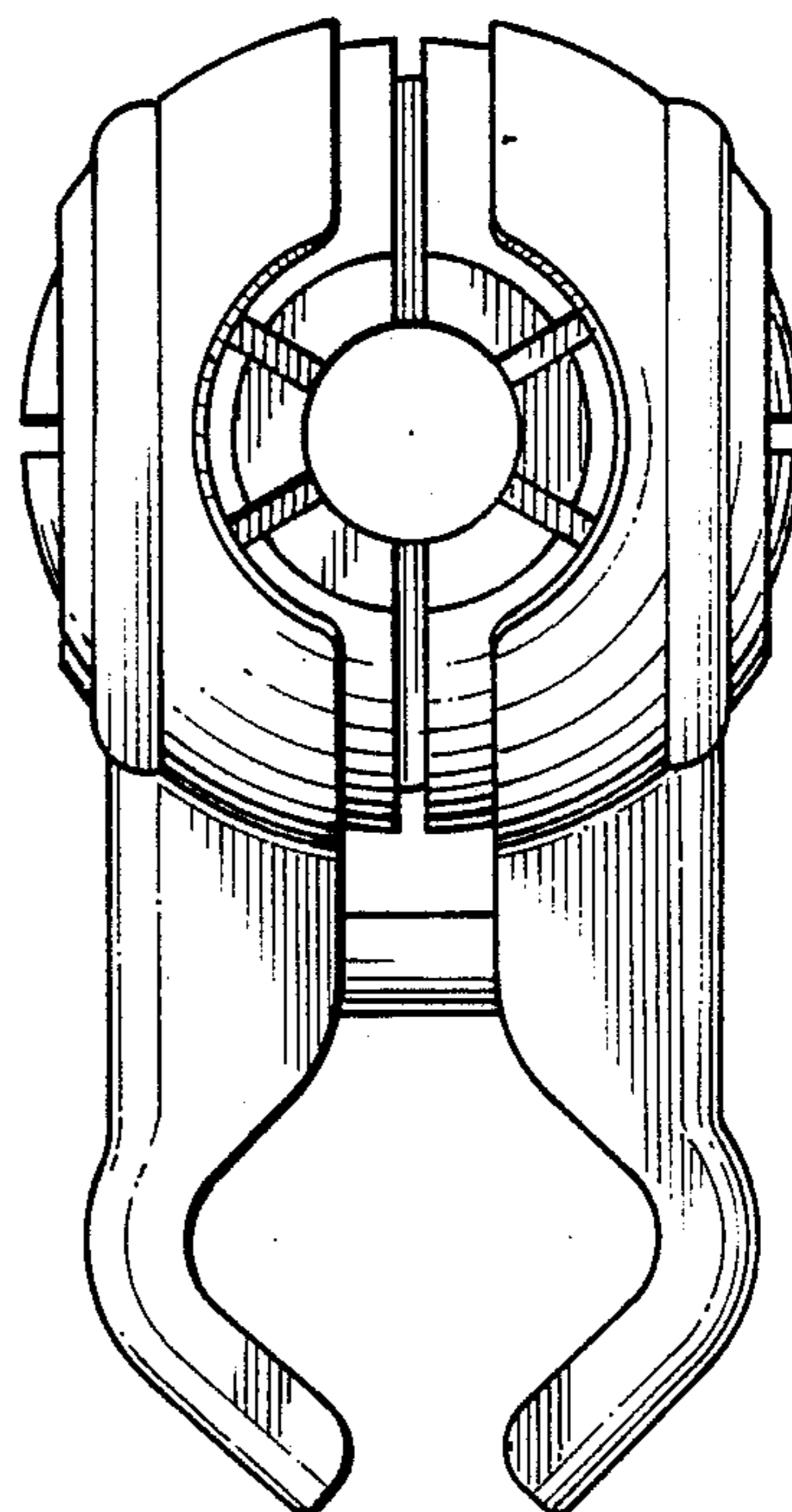

FIG. 3.

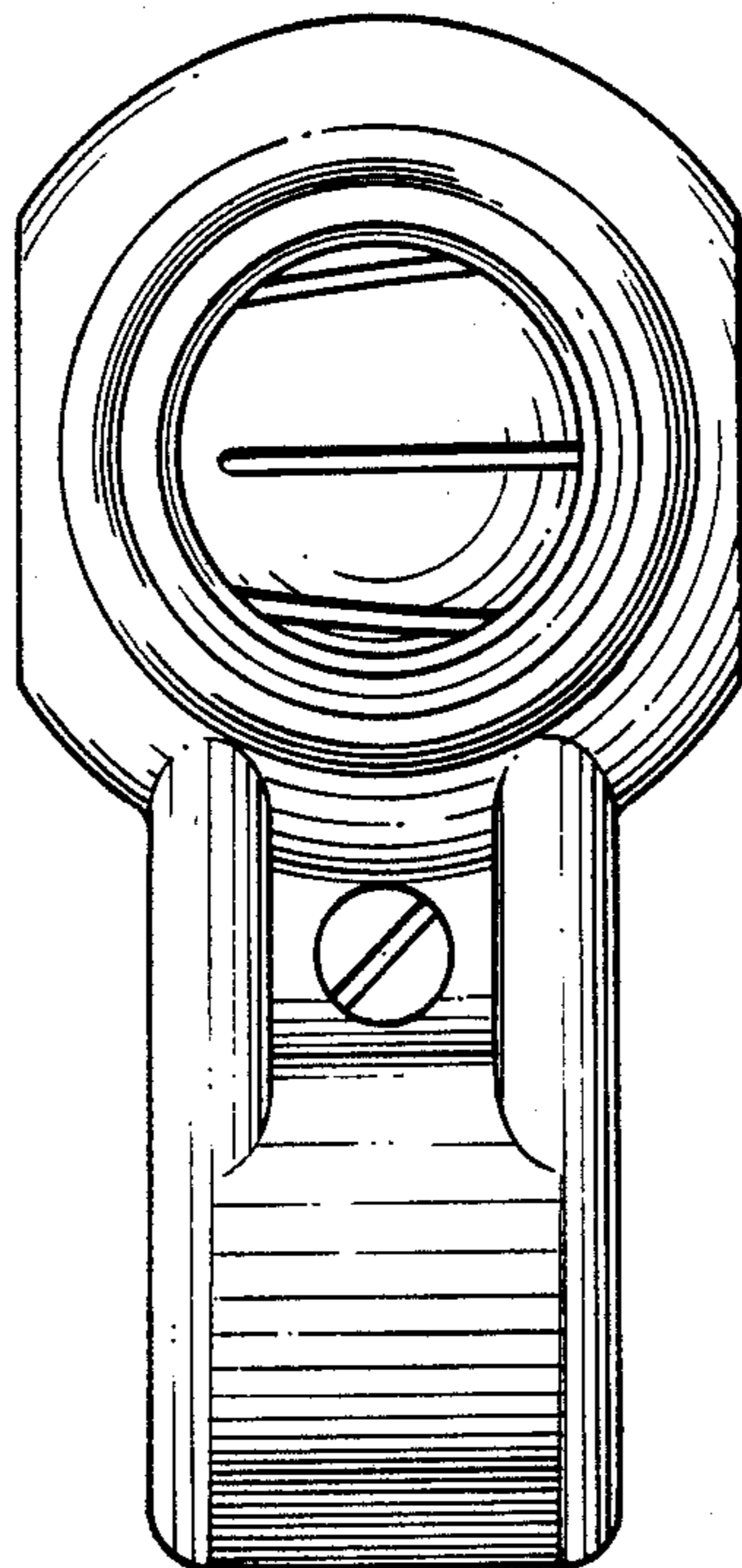

FIG. 4.

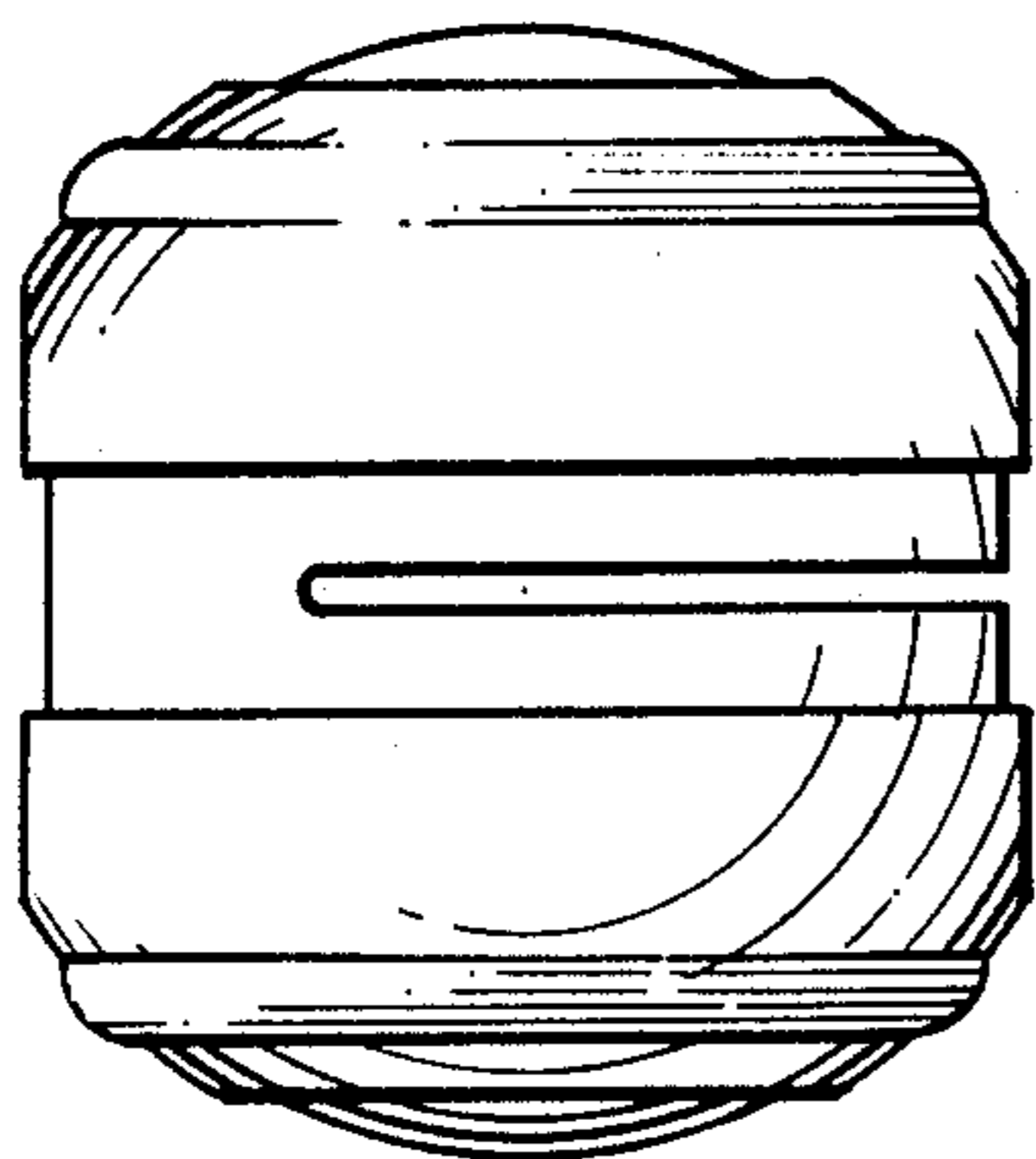

FIG. 5.

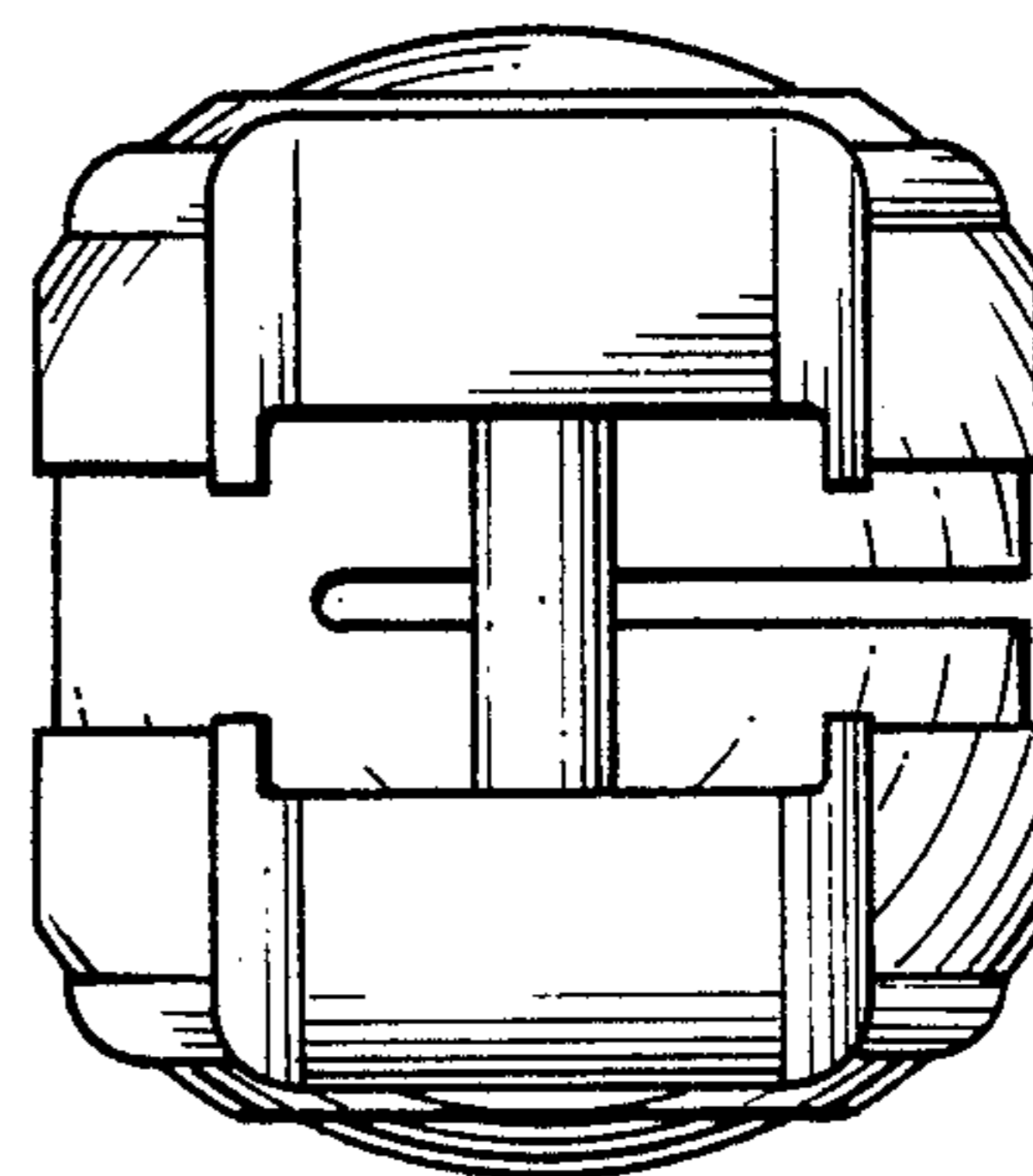

FIG. 6.