

[54] FLAIL APPARATUS FOR DELIMBING AND DEBARKING

[56] References Cited

U.S. PATENT DOCUMENTS

2,901,011	8/1959	Eaton	144/208 J
4,061,166	12/1977	Larson	144/208 J
4,690,187	9/1987	Schmidt	144/208
4,729,415	3/1988	Peterson et al.	144/208

[76] Inventor: Ronald D. Demlow, 6600 S. Shore Dr., Weidman, Mich. 48893

Primary Examiner—B. J. Bullock
Assistant Examiner—Sandra Morris
Attorney, Agent, or Firm—Ian C. McLeod

[**] Term: 14 Years

[57] CLAIM

[21] Appl. No.: 260,372

The ornamental design for a flail apparatus for delimiting and debarking, as shown.

[22] Filed: Oct. 20, 1988

DESCRIPTION

Related U.S. Application Data

FIG. 1 is a front elevational view of a flail apparatus for delimiting and debarking, showing my new design; FIG. 2 is a right side elevational view thereof; FIG. 3 is a left side elevational view thereof; FIG. 4 is a rear elevational view thereof, the broken lines showing an engine are for illustrative purposes only and form no part of the claimed design; FIG. 5 is a top plan view thereof.

[63] Continuation-in-part of Ser. No. 212,296, Jun. 27, 1988, Pat. No. 4,787,431.

[52] U.S. Cl. D15/124

[58] Field of Search D15/27, 122, 124; 144/208, 340, 341, 343

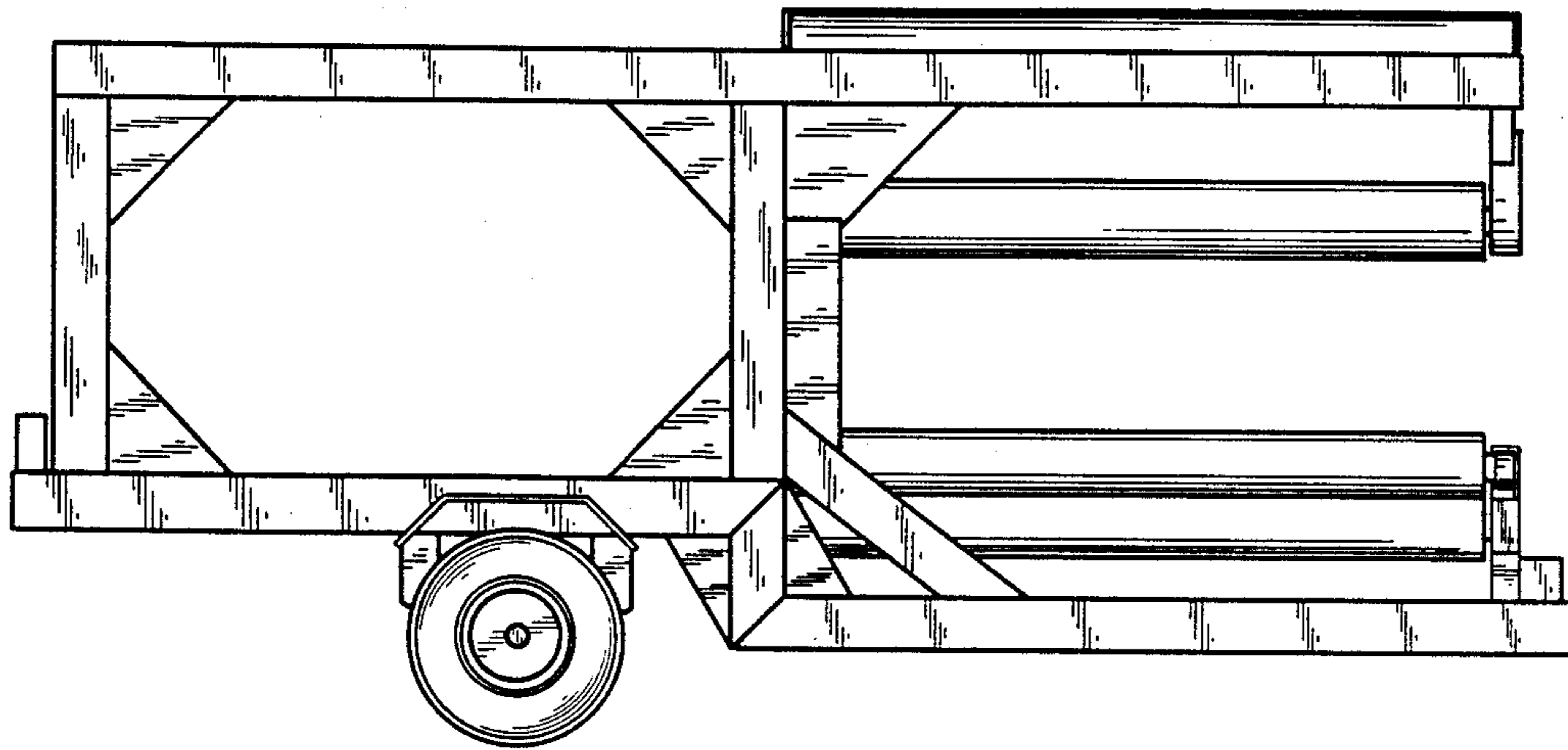

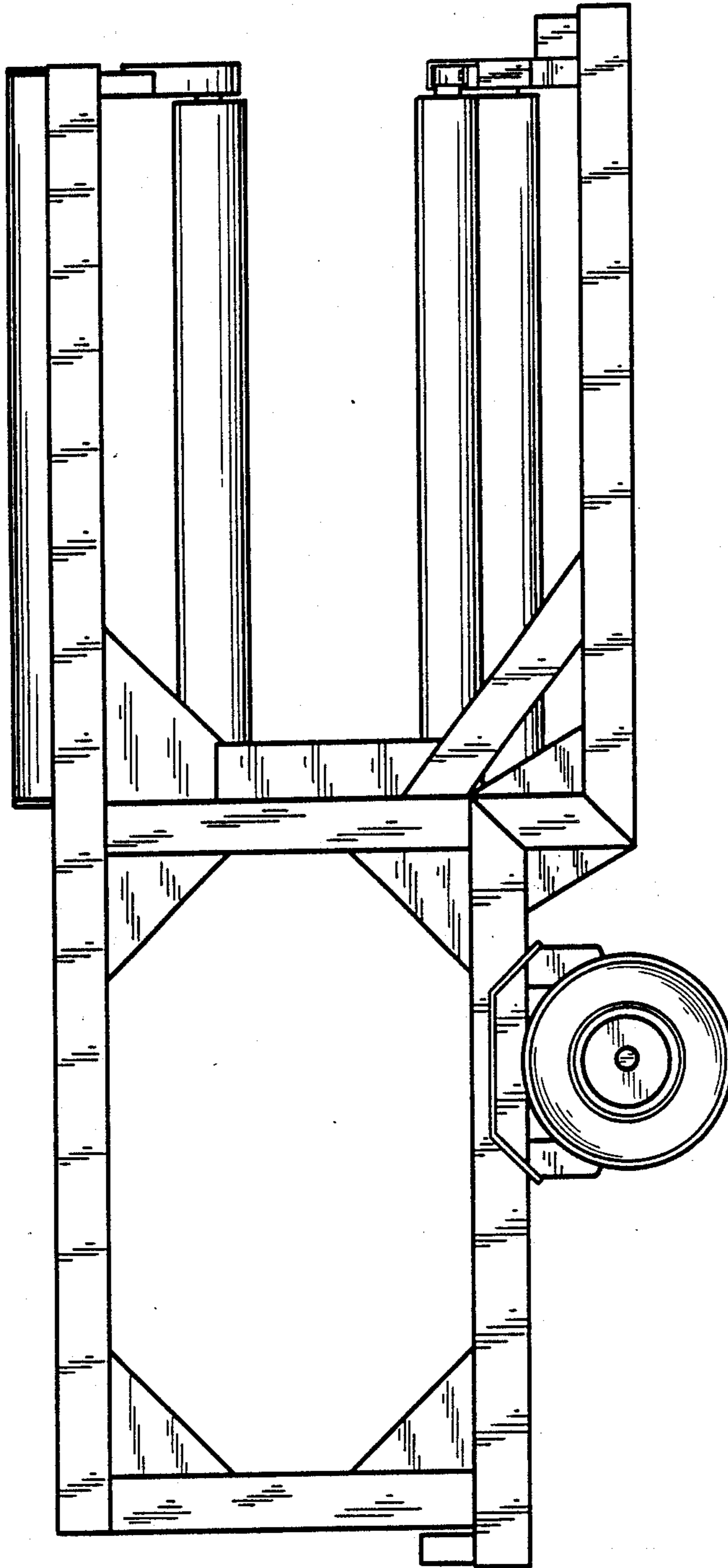

FIG. 1

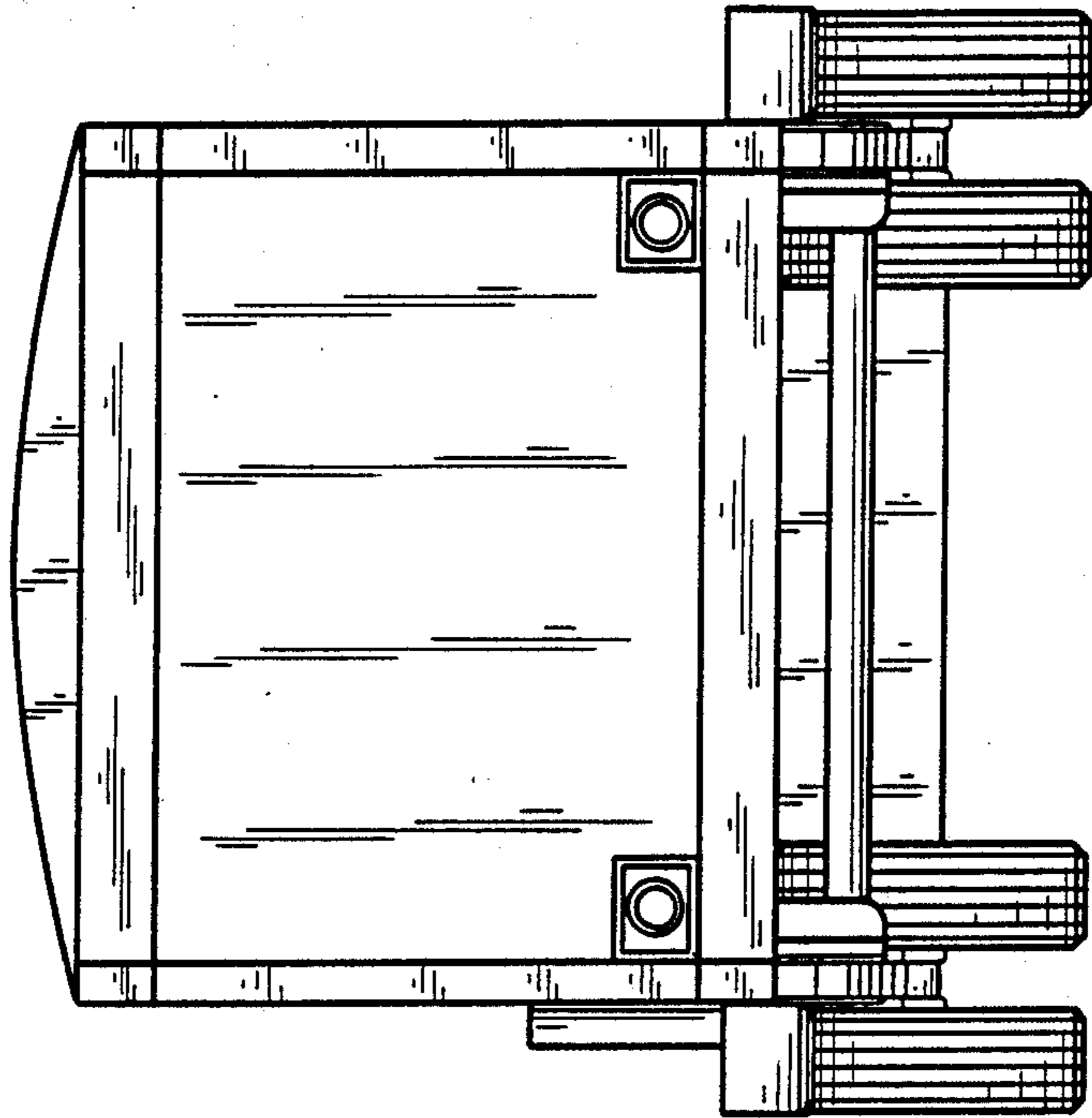

FIG. 3

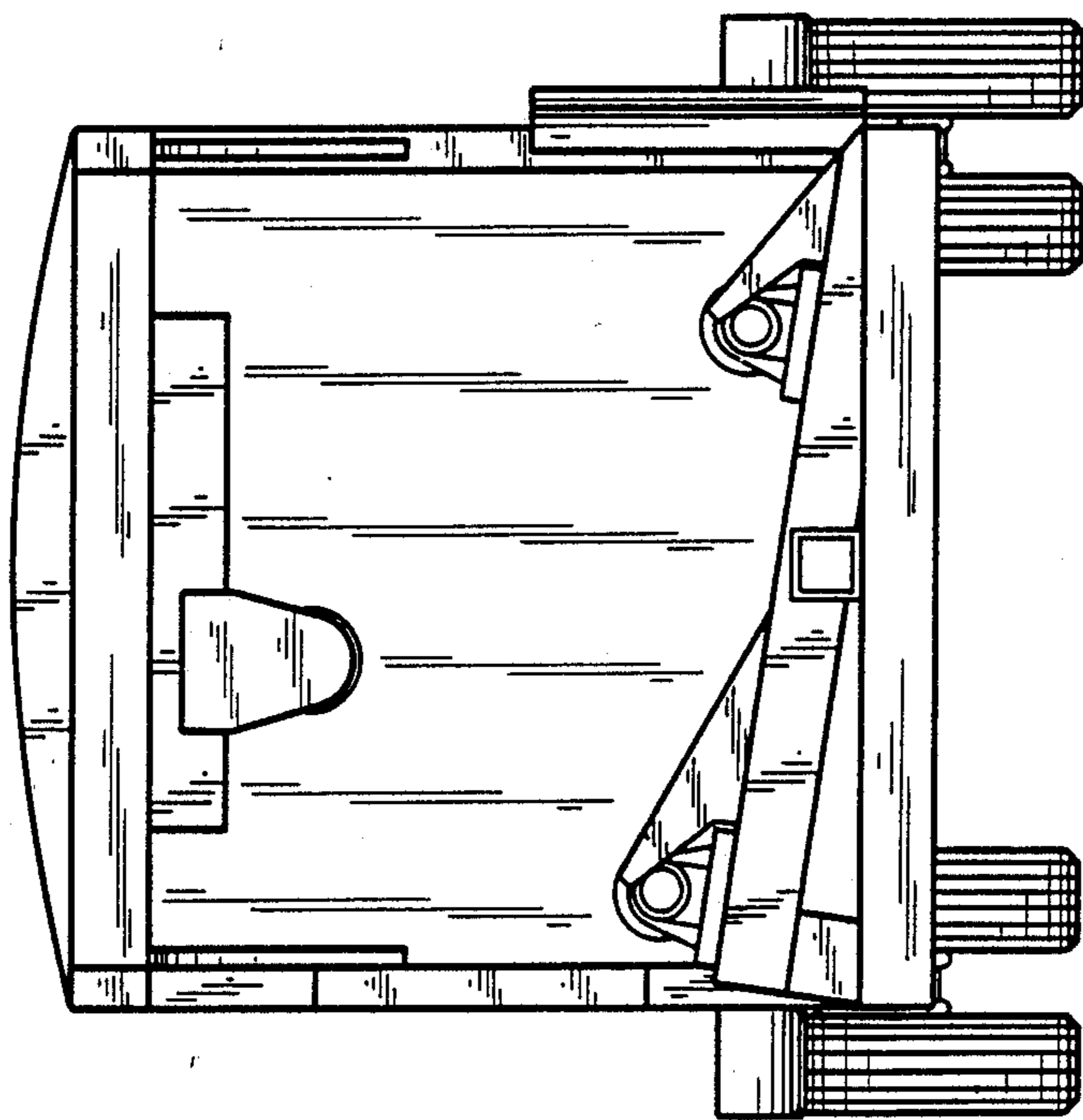
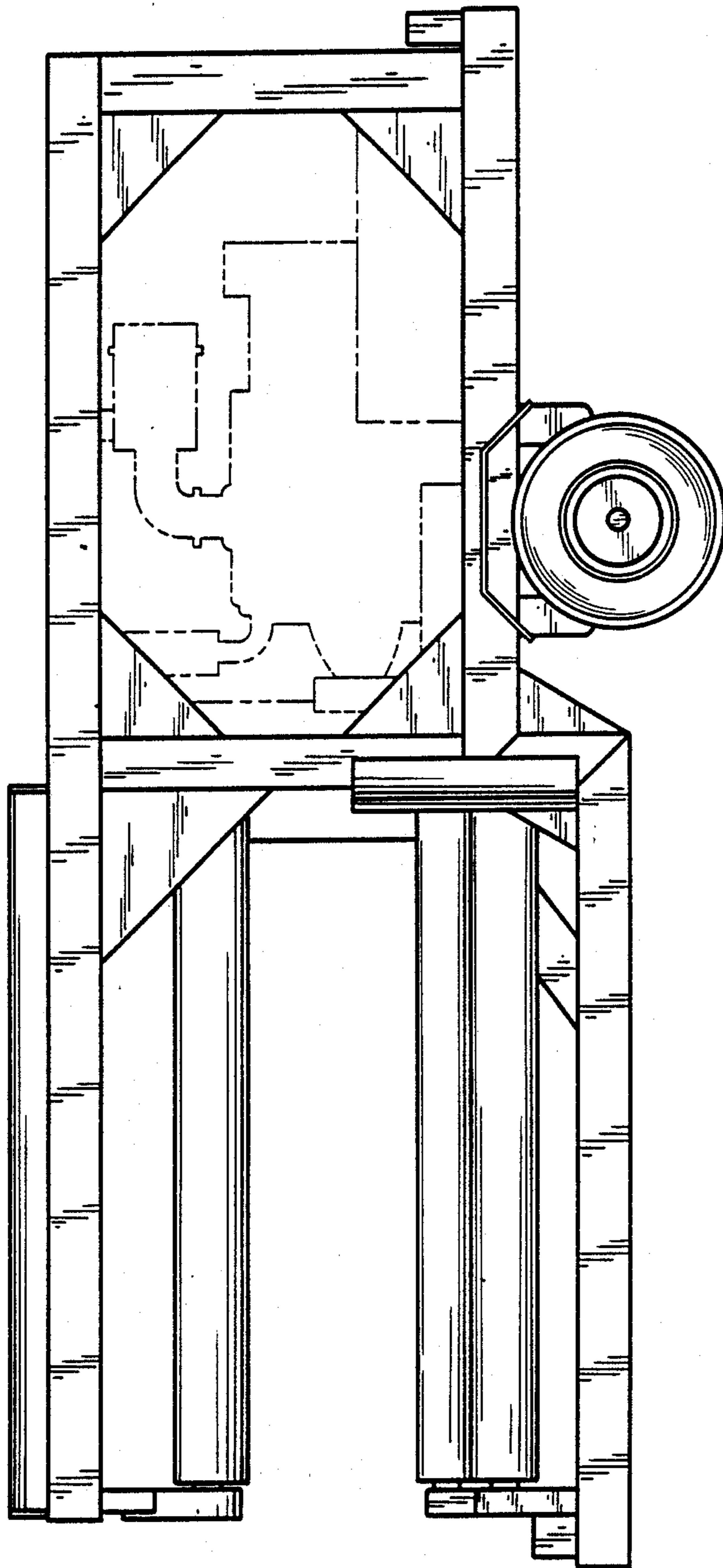

FIG. 2



—FIG. 4

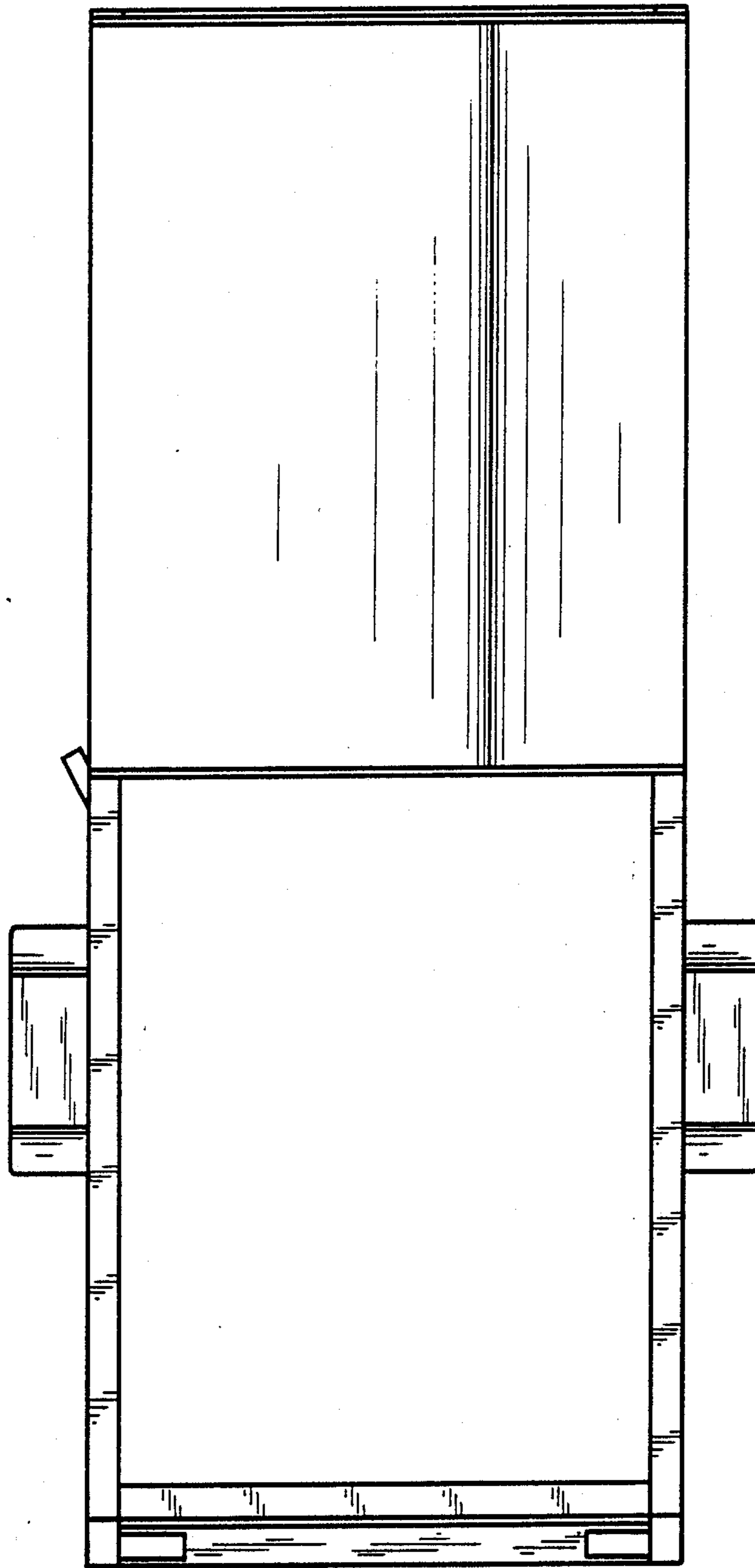

FIG. 5