

[54] TROLLING MOTOR HOUSING

[75] Inventor: Richard J. Robbins, Derby, Kans.

[73] Assignee: Zebco Corporation, Tulsa, Okla.

[**] Term: 14 Years

[21] Appl. No.: 224,585

[22] Filed: Jul. 26, 1988

[52] U.S. Cl. D15/4

[58] Field of Search D15/4; 440/900, 3, 6; 290/43, 46, 54

[56] References Cited

U.S. PATENT DOCUMENTS

- D. 219,558 12/1970 Fetty D15/4
- D. 276,811 12/1984 Wolfe D15/4
- 3,812,379 5/1974 Kaufman et al. D15/4 X
- 4,008,680 2/1977 Alexander, Jr. 440/6
- 4,311,470 1/1982 Blanchard 440/6

OTHER PUBLICATIONS

Minn Kota 1989 Catalog, pp. 10 and 11.

Shakespeare 1987 Catalog, pp. 52 and 53.
MotorGuide 1988 Catalog, pp. 4 and 5.

Primary Examiner—A. Hugo Word
Assistant Examiner—Doris V. Coles
Attorney, Agent, or Firm—Wood, Phillips, Mason,
Recktenwald & Van Santen

[57] CLAIM

The ornamental design for a trolling motor housing, as shown and described.

DESCRIPTION

FIG. 1 is a right side and front perspective view of a trolling motor housing, showing my new design;
FIG. 2 is a top plan view thereof;
FIG. 3 is a left side elevational view thereof;
FIG. 4 is a front elevational view thereof;
FIG. 5 is a rear elevational view thereof;
FIG. 6 is a right side elevational view thereof; and
FIG. 7 is a bottom plan view thereof.

The broken lines shown in phantom in FIG. 1 are for illustrative purposes only and form no part of the claimed design.

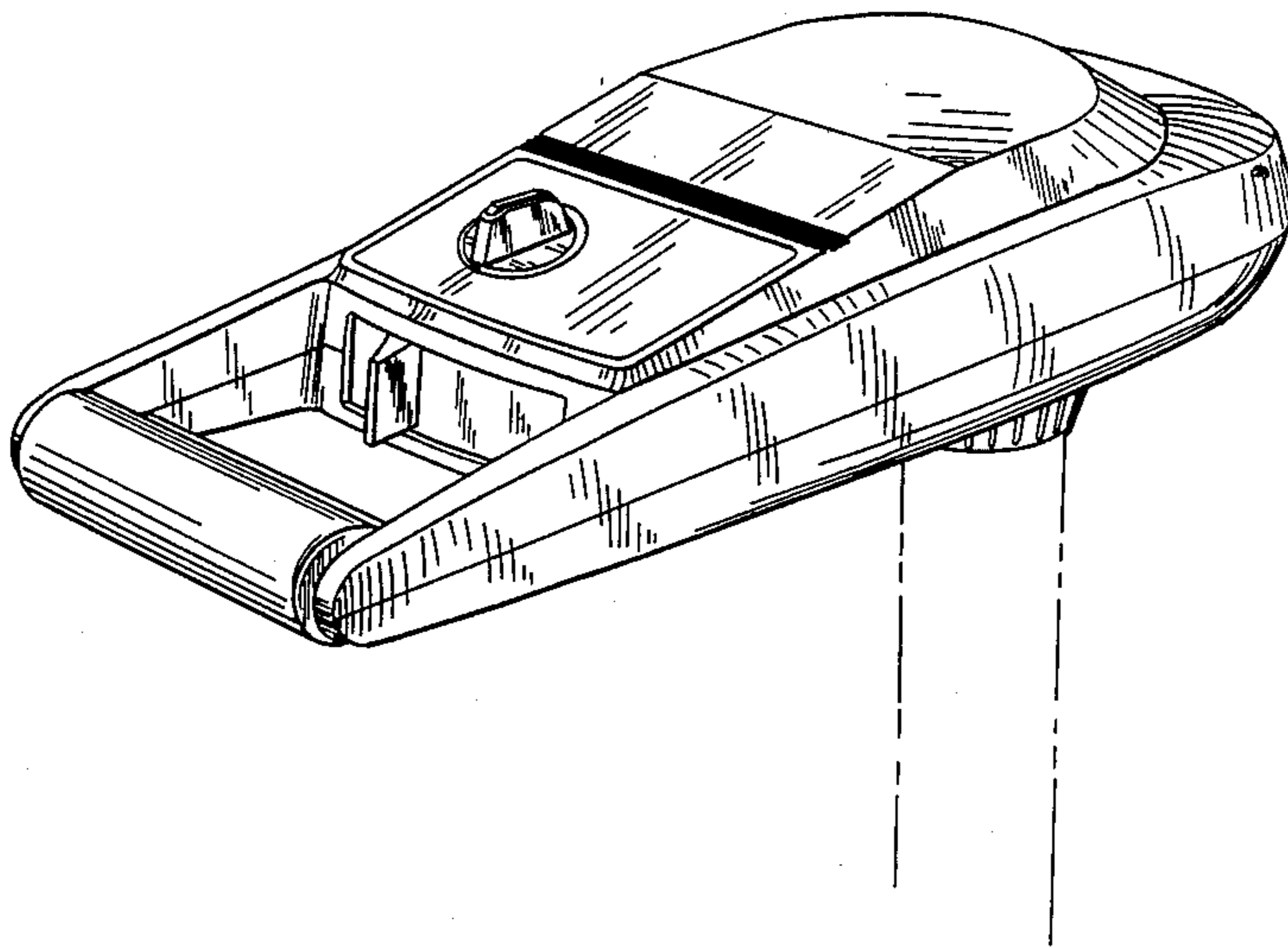

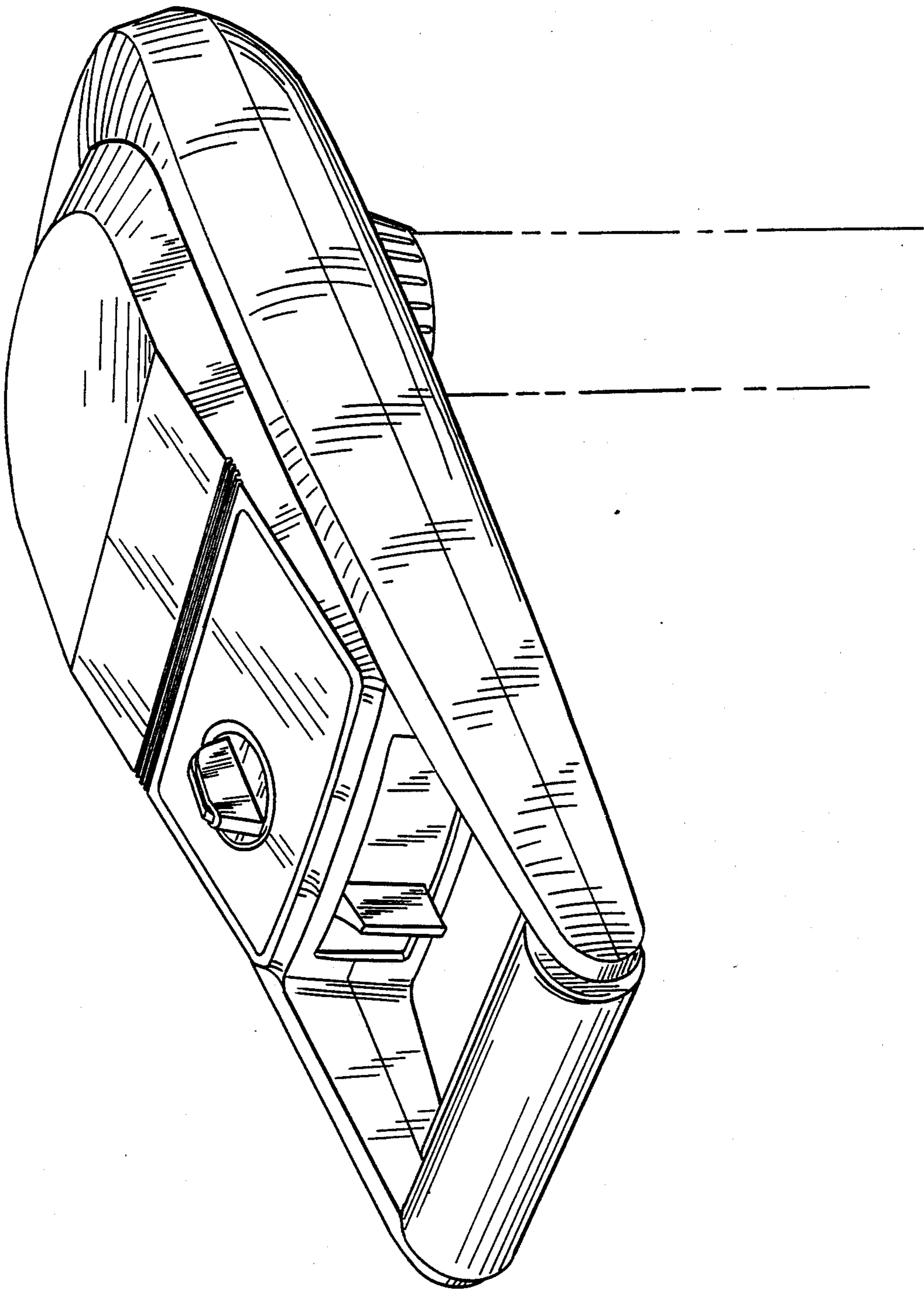

FIG. 1

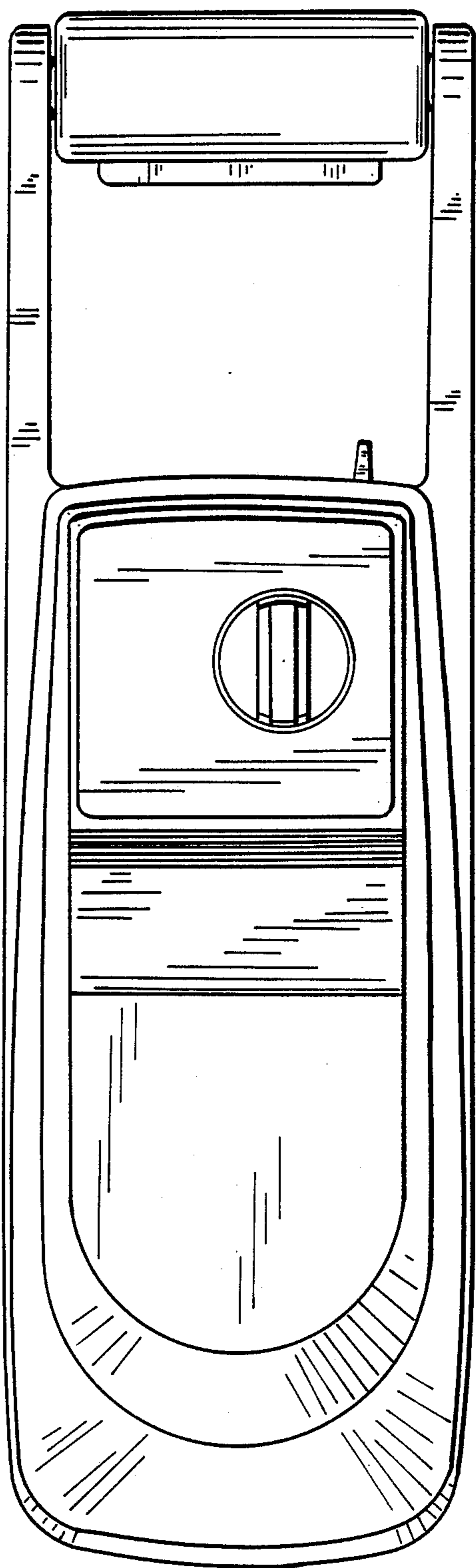

FIG. 2

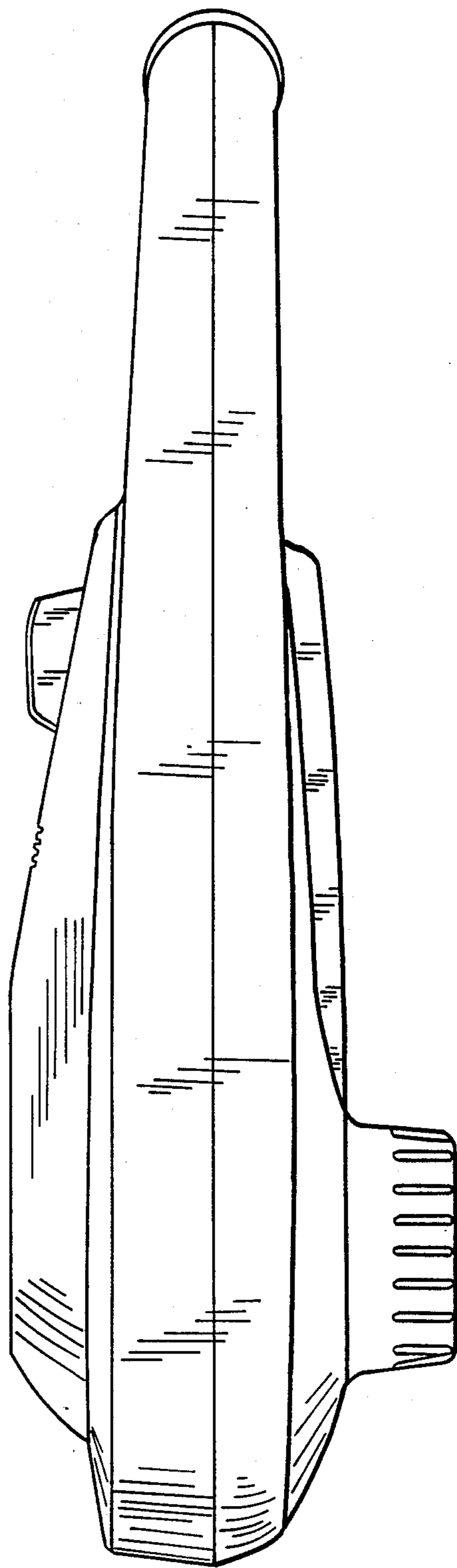

FIG. 3

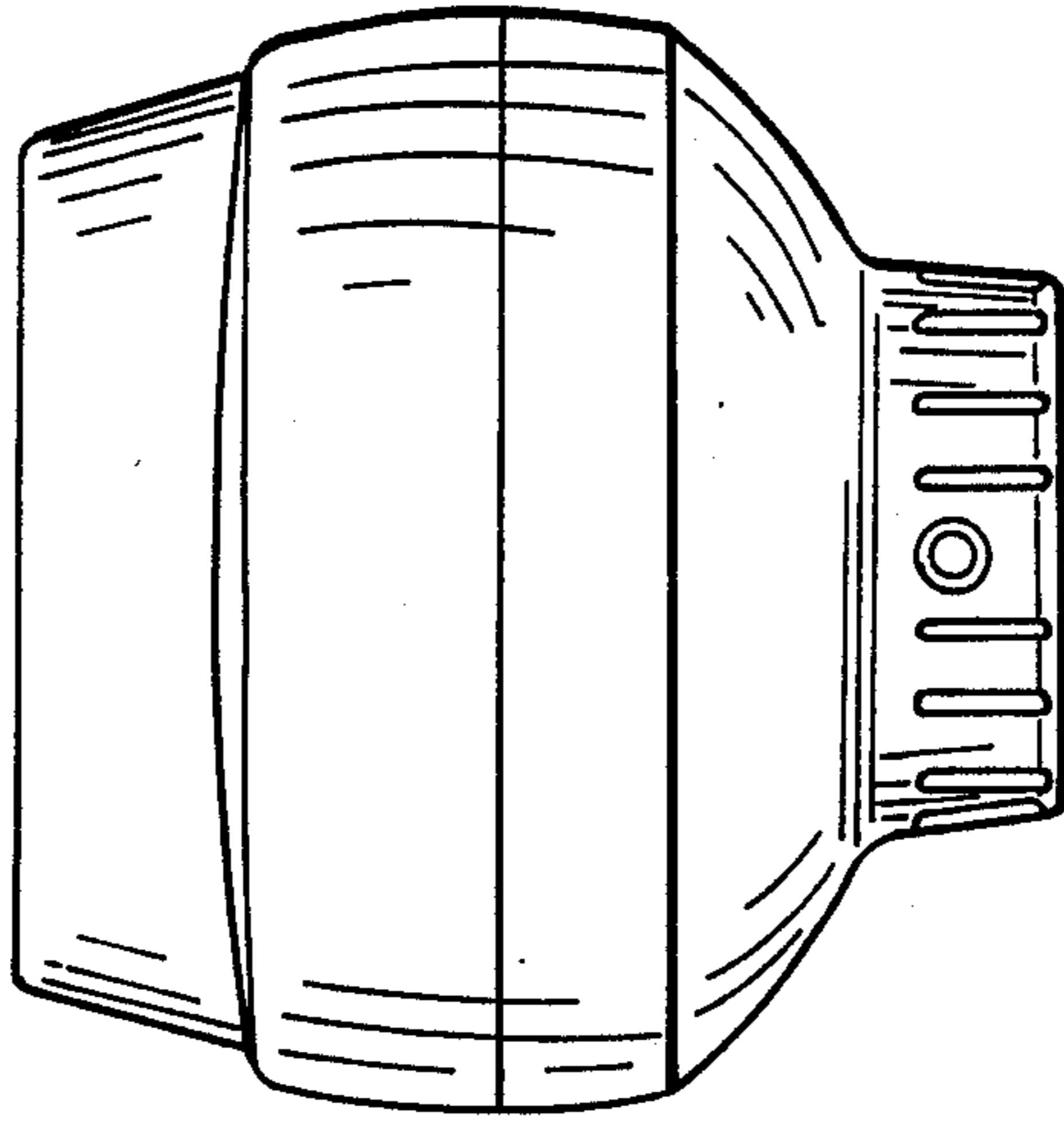

FIG. 5

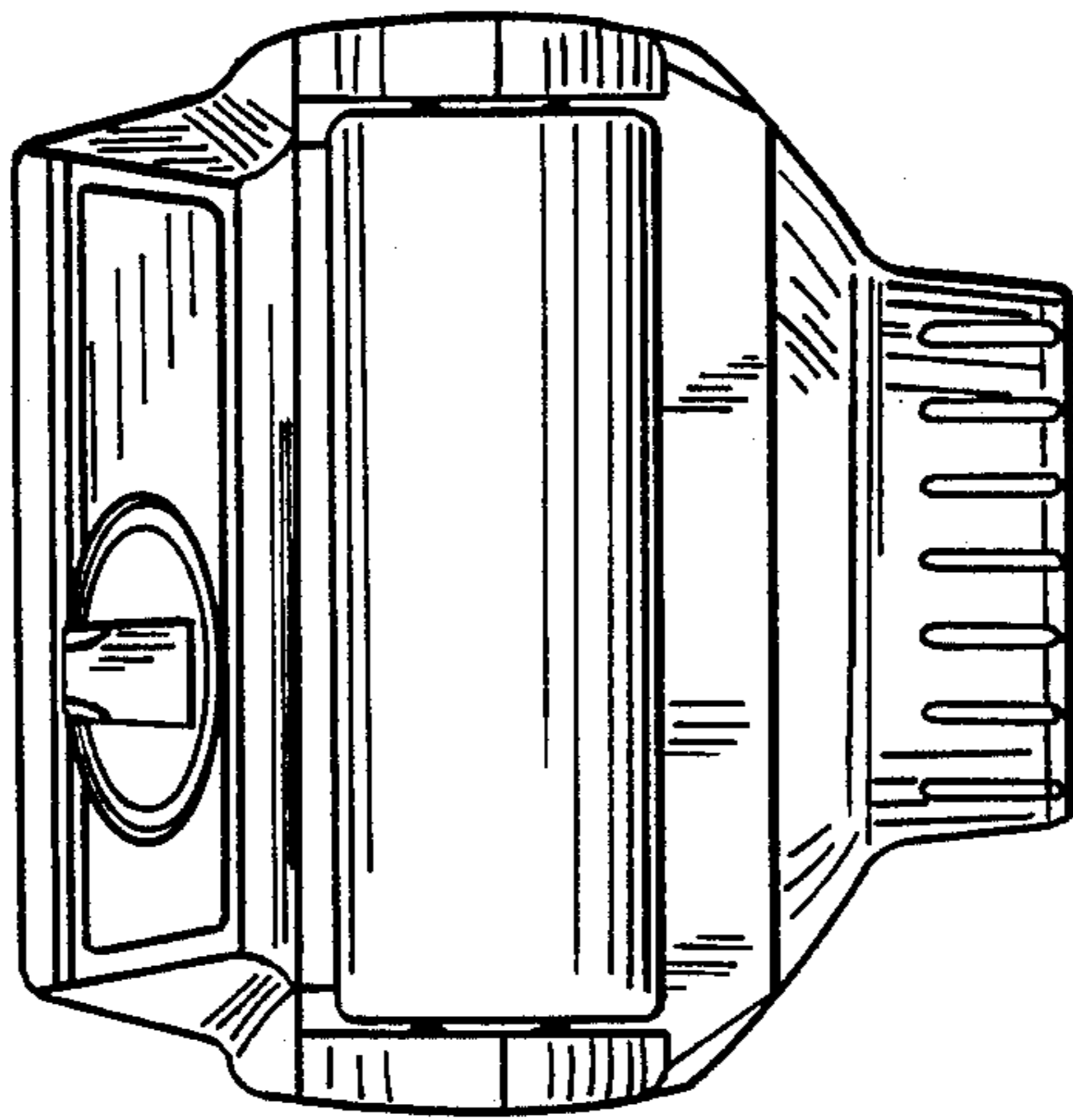

FIG. 4

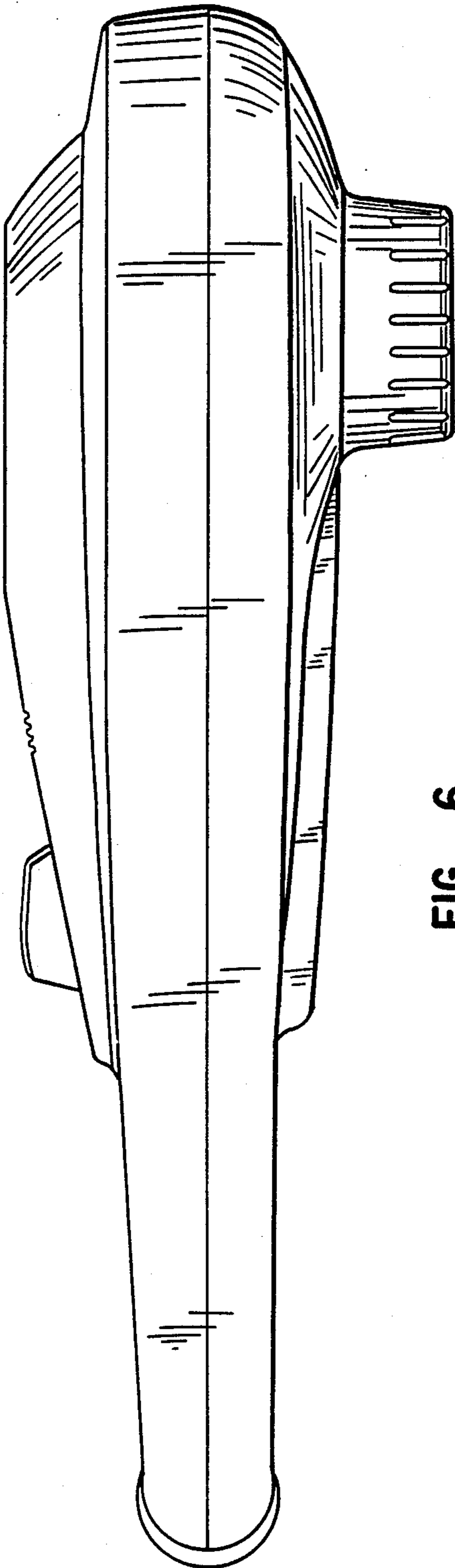

FIG. 6

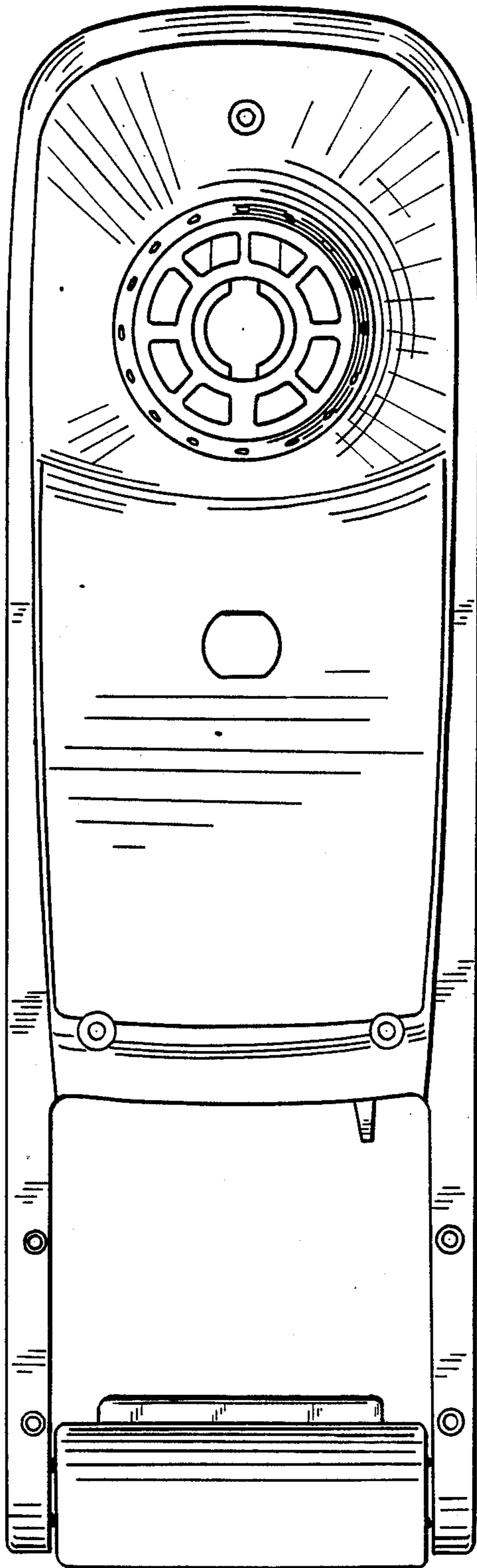

FIG. 7