

[54] EXTENSIBLE CRADLE SUPPORT FOR RECREATIONAL VEHICLE DRAIN HOSE OR SIMILAR ARTICLE

[76] Inventor: John E. Cassity, 12575 S. 1450 West, Riverton, Utah 84065

[\*\*] Term: 14 Years

[21] Appl. No.: 11,496

[22] Filed: Feb. 5, 1987

[52] U.S. Cl. .... D8/380; D12/106; 248/49

[58] Field of Search ..... D8/356, 380; D12/106

[56] References Cited

U.S. PATENT DOCUMENTS

D. 260,600	9/1981	Taylor	.....	D8/356
4,125,237	11/1978	Hagins	.....	248/49
4,169,571	10/1979	Duggan	.....	248/49
4,228,978	10/1980	Rand	.....	248/49
4,363,931	12/1982	Simons	.....	248/49 X
4,406,434	9/1983	Schneckloth	.....	248/49 X
4,526,090	7/1985	Maier	.....	248/49 X
4,582,281	4/1986	Von Camp	.....	248/49 X
4,620,339	11/1986	Shepherd	.....	248/49 X

Primary Examiner—Horace B. Fay, Jr.

Attorney, Agent, or Firm—M. Ralph Shaffer

[57] CLAIM

The ornamental design for extensible cradle support for a recreational vehicle drain hose or similar article.

DESCRIPTION

FIG. 1 is a side elevational view of an extensible cradle support for a recreational vehicle drain hose or similar article showing my new design, with a fragmentary side view of a vehicle and a drain hose in broken lines cradled upon the supports;

FIG. 2 is a perspective view of the cradle support in extended length and height when in use;

FIG. 3 is a side elevational view thereof in non-extended horizontal position, and with the extensible legs in uniform length for storage convenience;

FIG. 4 is a top plan view of the design form condition of FIG. 3;

FIG. 5 is a side elevational view opposite to that of FIG. 3;

FIG. 6 is a bottom plan view thereof;

FIGS. 7 and 8 are respectively front and rear elevational views of FIG. 2.

The broken line showing of a fragmentary side elevational view of a recreational vehicle and a drain hose in FIG. 1 is for illustrative purposes only and forms no part of the claimed design.

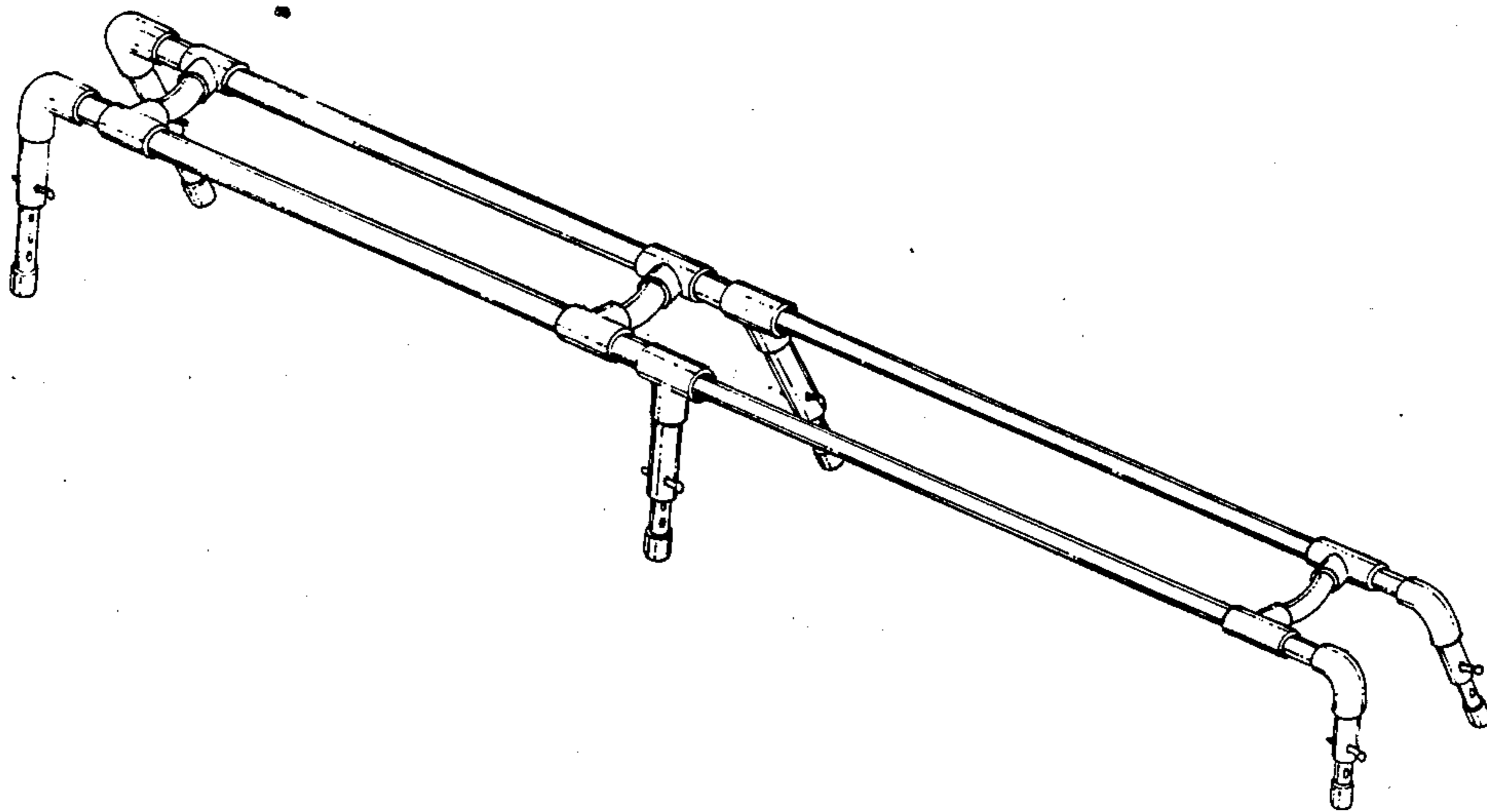

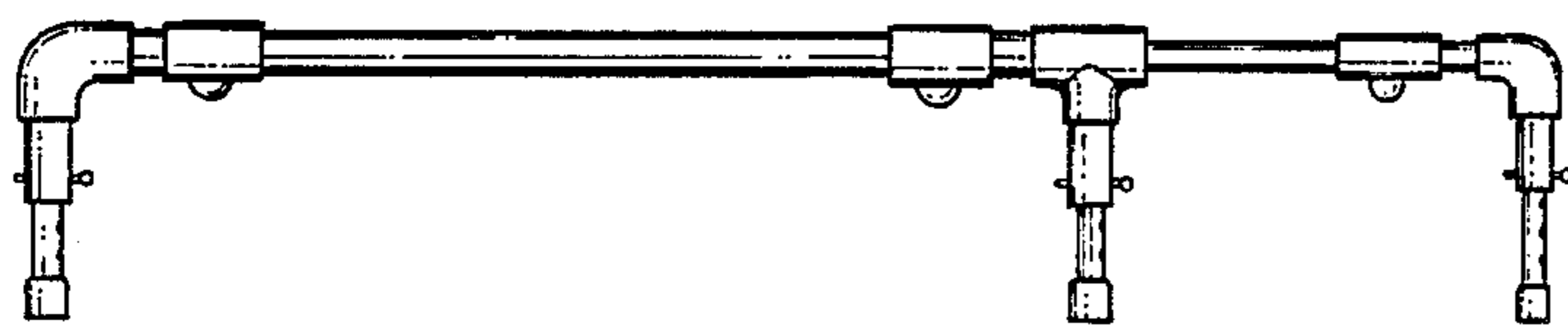
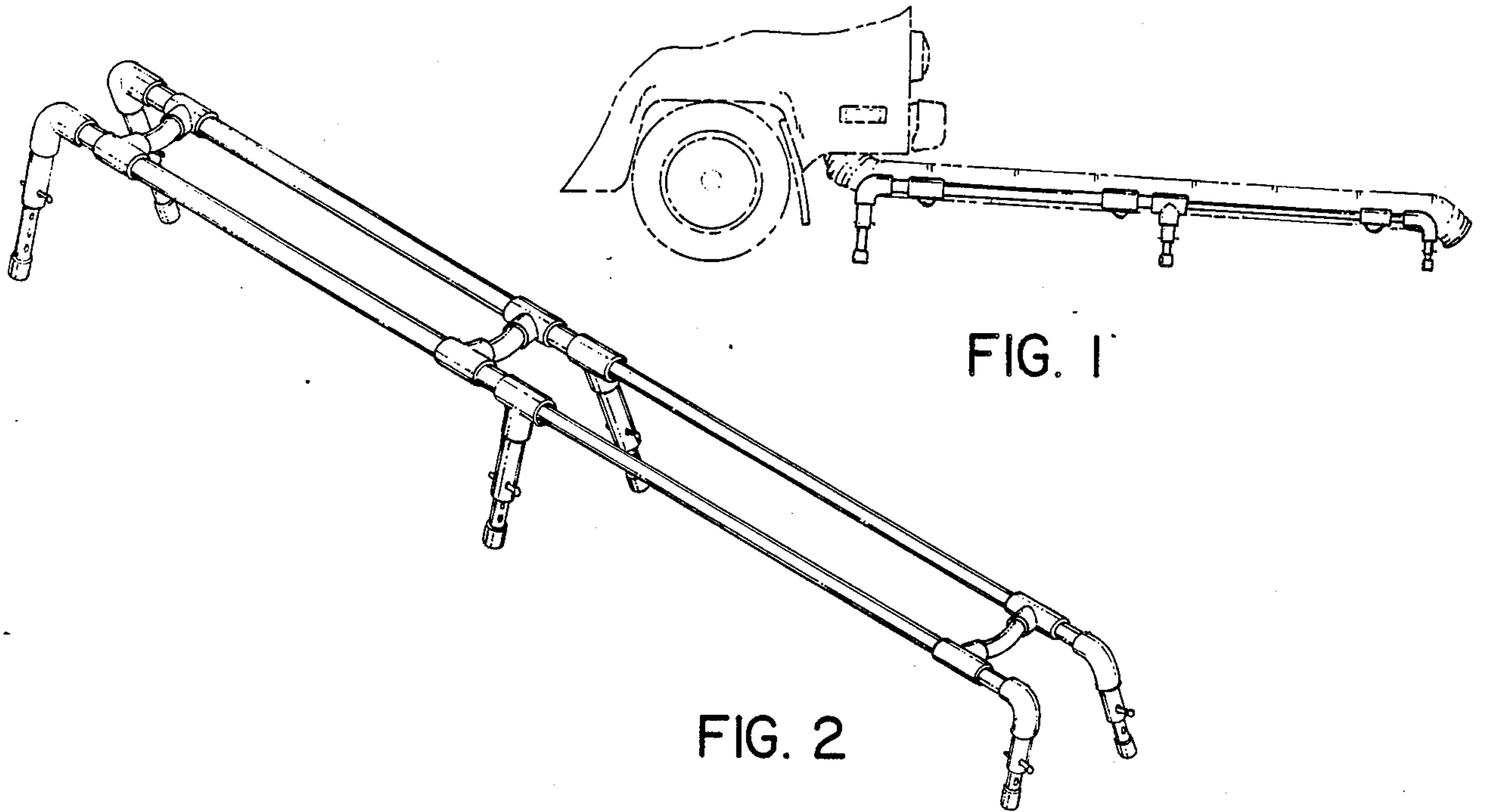

FIG. 3

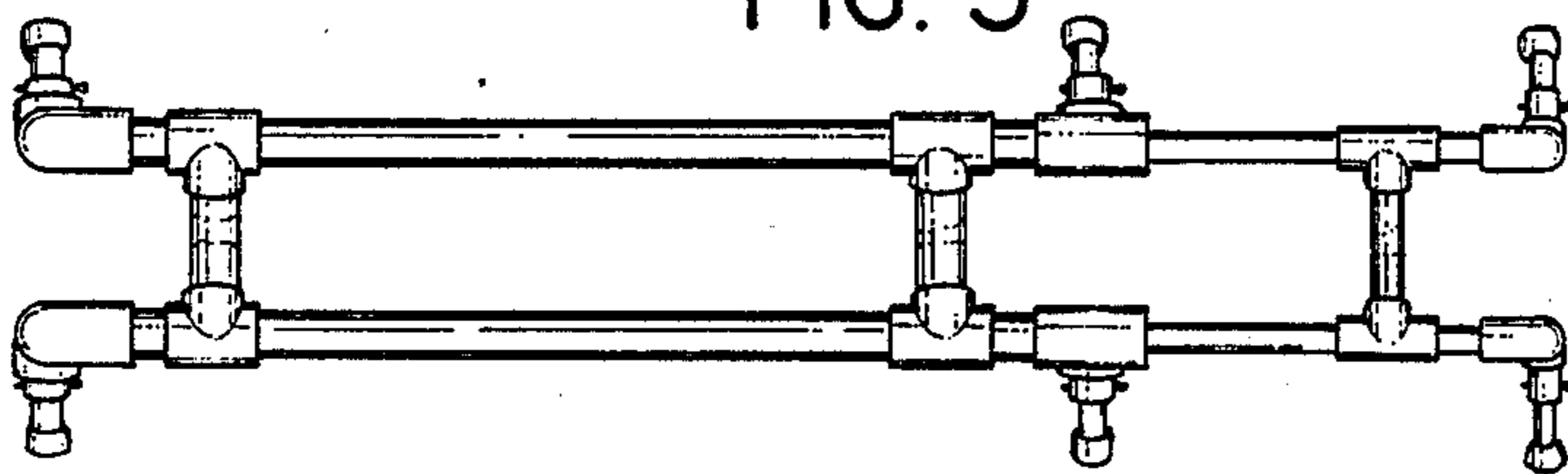

FIG. 4

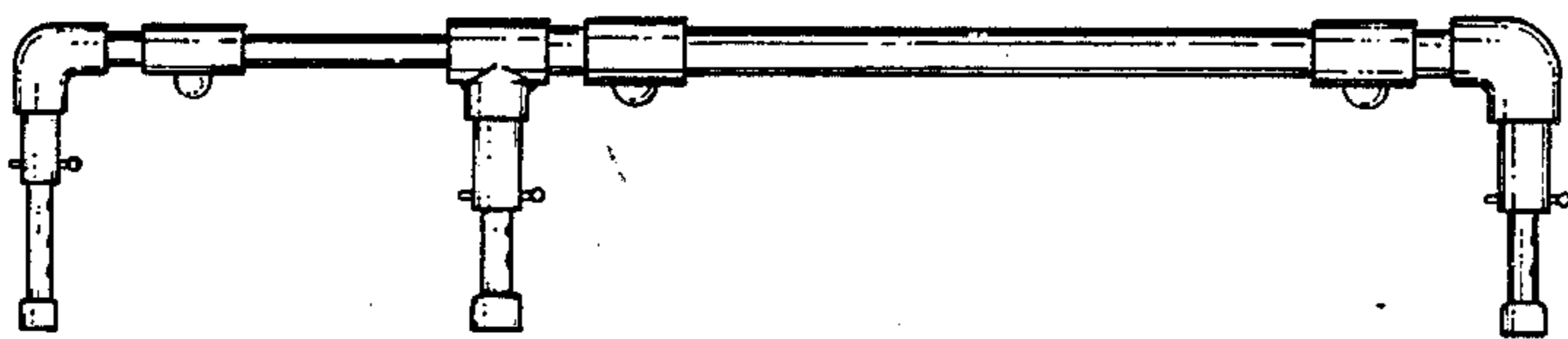

FIG. 5

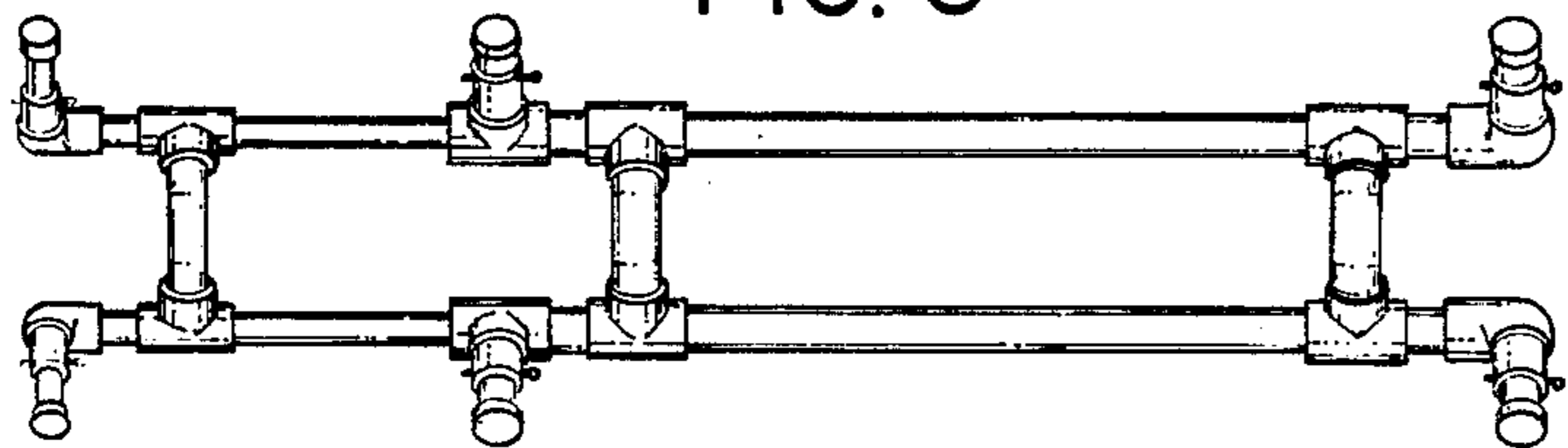

FIG. 6

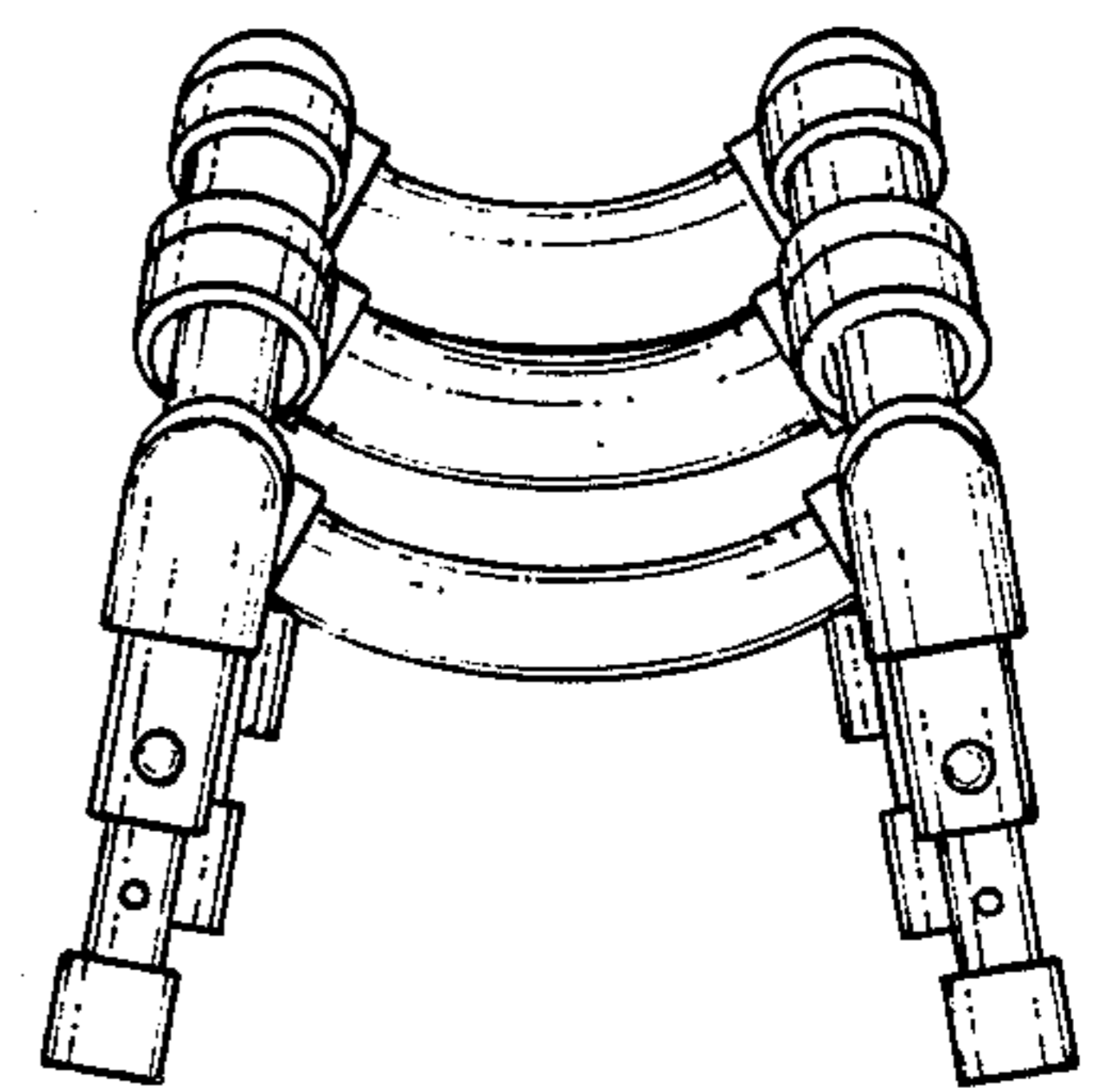

FIG. 7

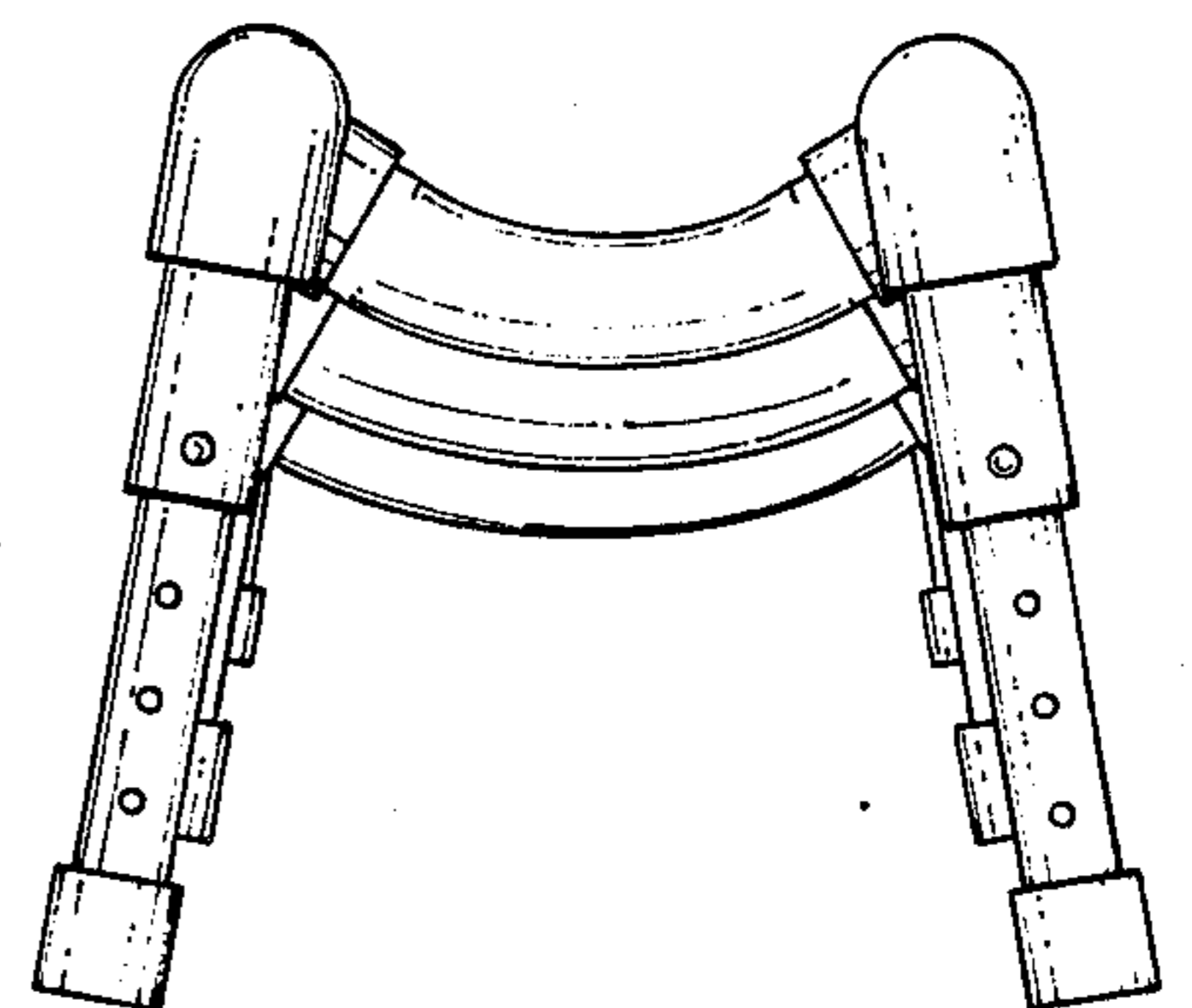

FIG. 8