

[54] UMBRELLA HOLDER FOR A MOTOR VEHICLE

[76] Inventor: Stanley Moll, 14-6 Granada Crescent, White Plains, N.Y. 10603

[\*\*] Term: 14 Years

[21] Appl. No.: 22,423

[22] Filed: Mar. 6, 1987

[52] U.S. Cl. .... D3/40; D3/10

[58] Field of Search ..... D3/5-17, D3/40; D6/416, 512, 513; 248/155-155.2; 135/20 R; 224/915, 42.11, 42.42 R, 273, 275

[56] References Cited

U.S. PATENT DOCUMENTS

D. 27,777	10/1897	Sperry	.....	D3/10
D. 196,024	8/1963	McManus	.....	D3/10
D. 201,246	6/1965	Spangle	.....	D3/10 X
D. 283,381	4/1986	Bakker et al.	.....	D3/10 X
2,926,826	3/1960	Conrad	.....	224/915 X
3,554,203	1/1971	Hall, Sr.	.....	135/20 R

FOREIGN PATENT DOCUMENTS

613456 1/1961 Canada ..... 224/915 X

Primary Examiner—Louis S. Zarfes  
Attorney, Agent, or Firm—Anthony J. Casella; Gerald E. Hespos

[57] CLAIM

The ornamental design for an umbrella holder for a motor vehicle, as shown and described.

DESCRIPTION

FIG. 1 is a perspective view of an umbrella holder for a motor vehicle showing my new design; FIG. 2 is a bottom plan view; FIG. 3 is a top plan view; FIG. 4 is a front elevational view; FIG. 5 is a rear elevational view; and FIG. 6 is a left side elevational view, the right side being a mirror image.

The broken line showing of a motor vehicle seat in FIG. 1 is for illustrative purposes only and forms no part of the claimed design.

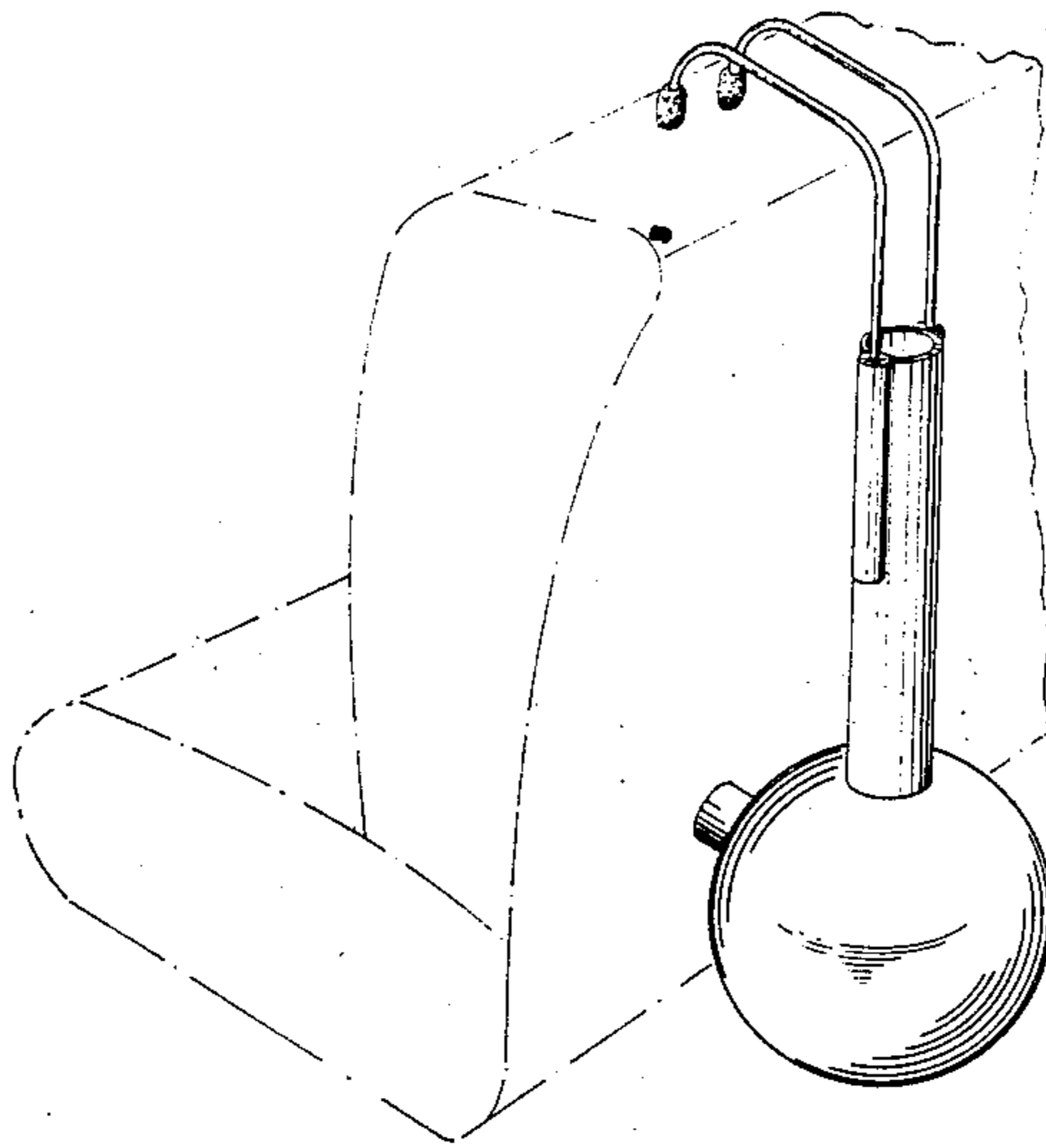

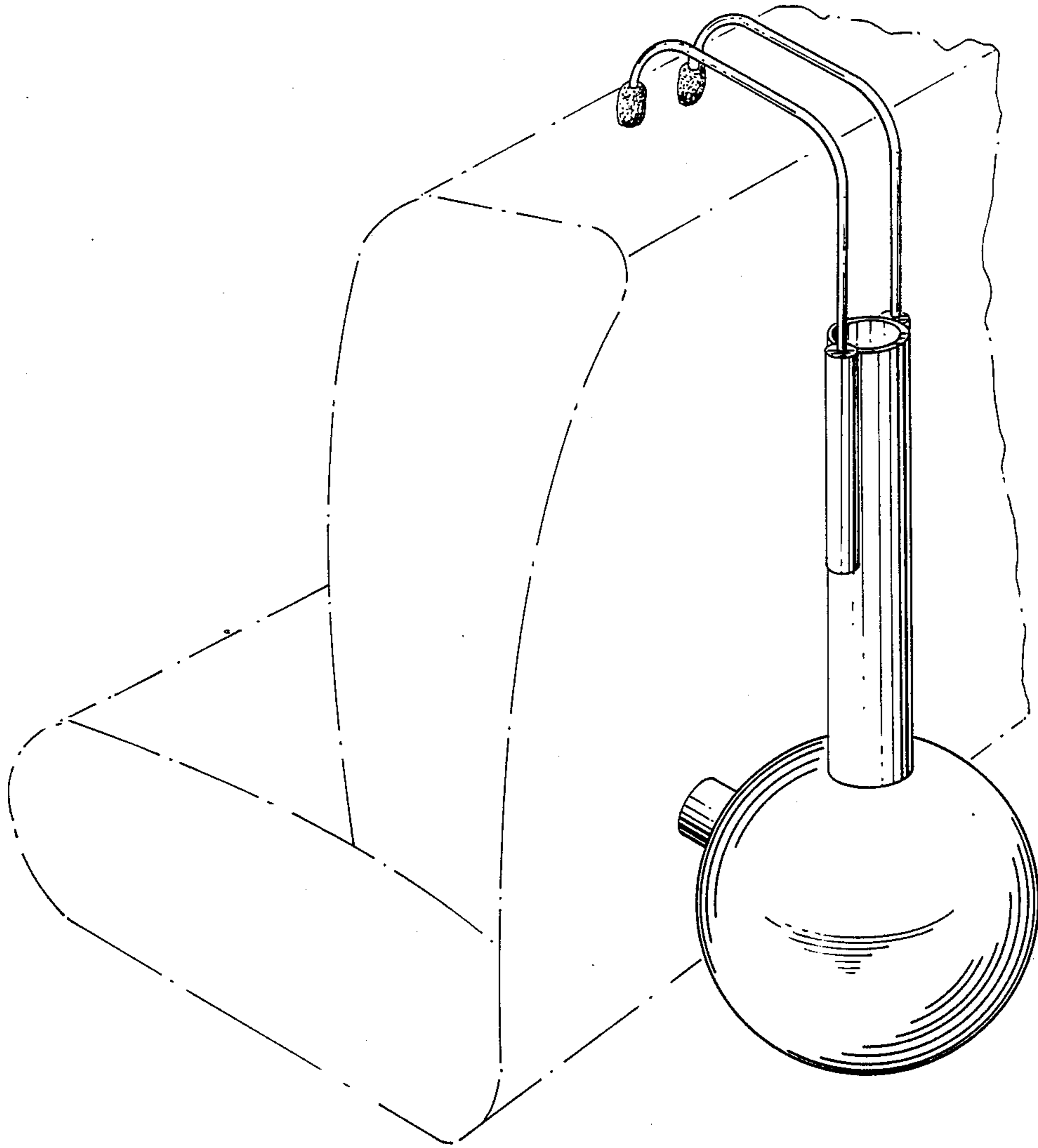

FIG. 1

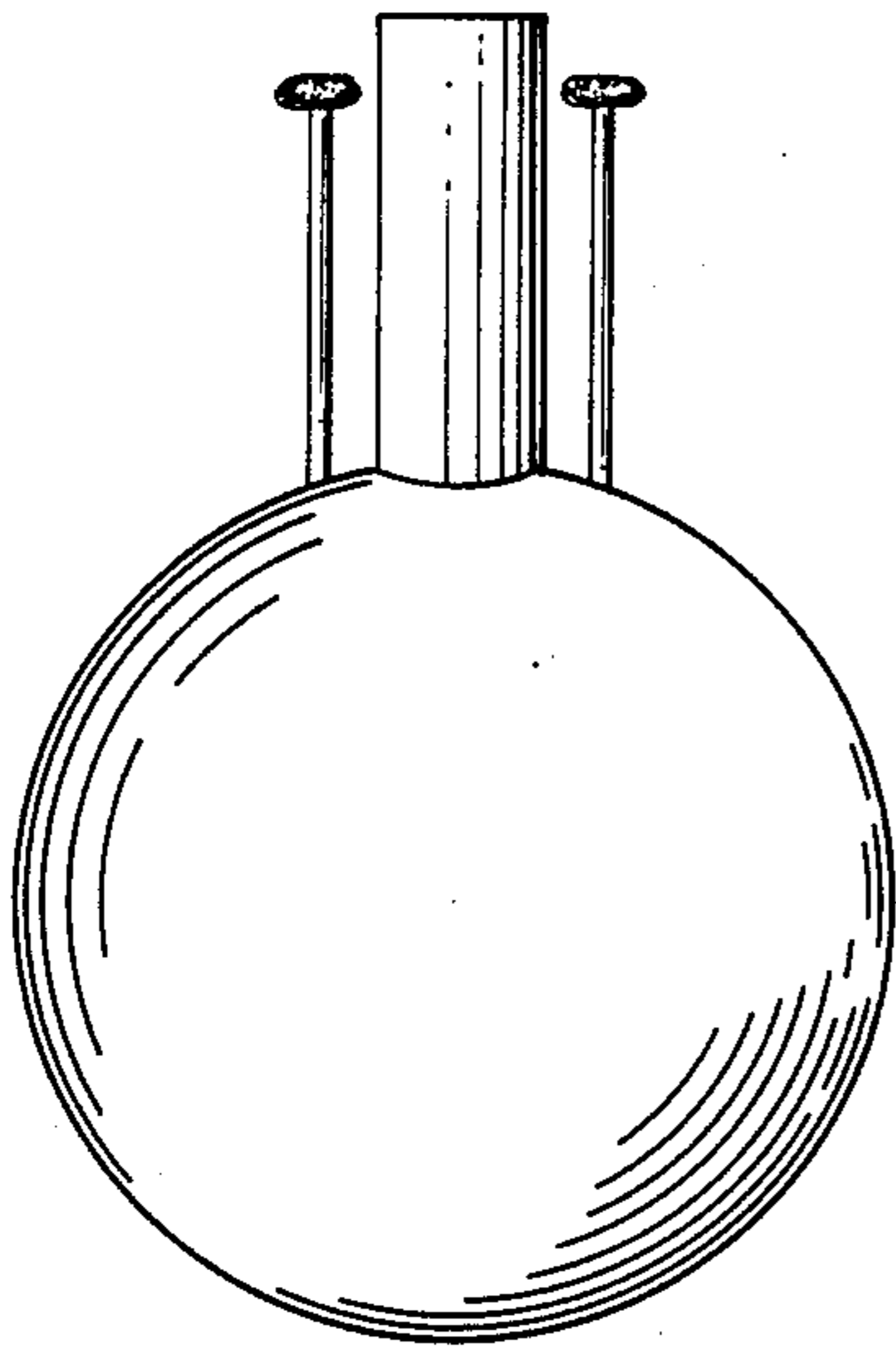

FIG. 2

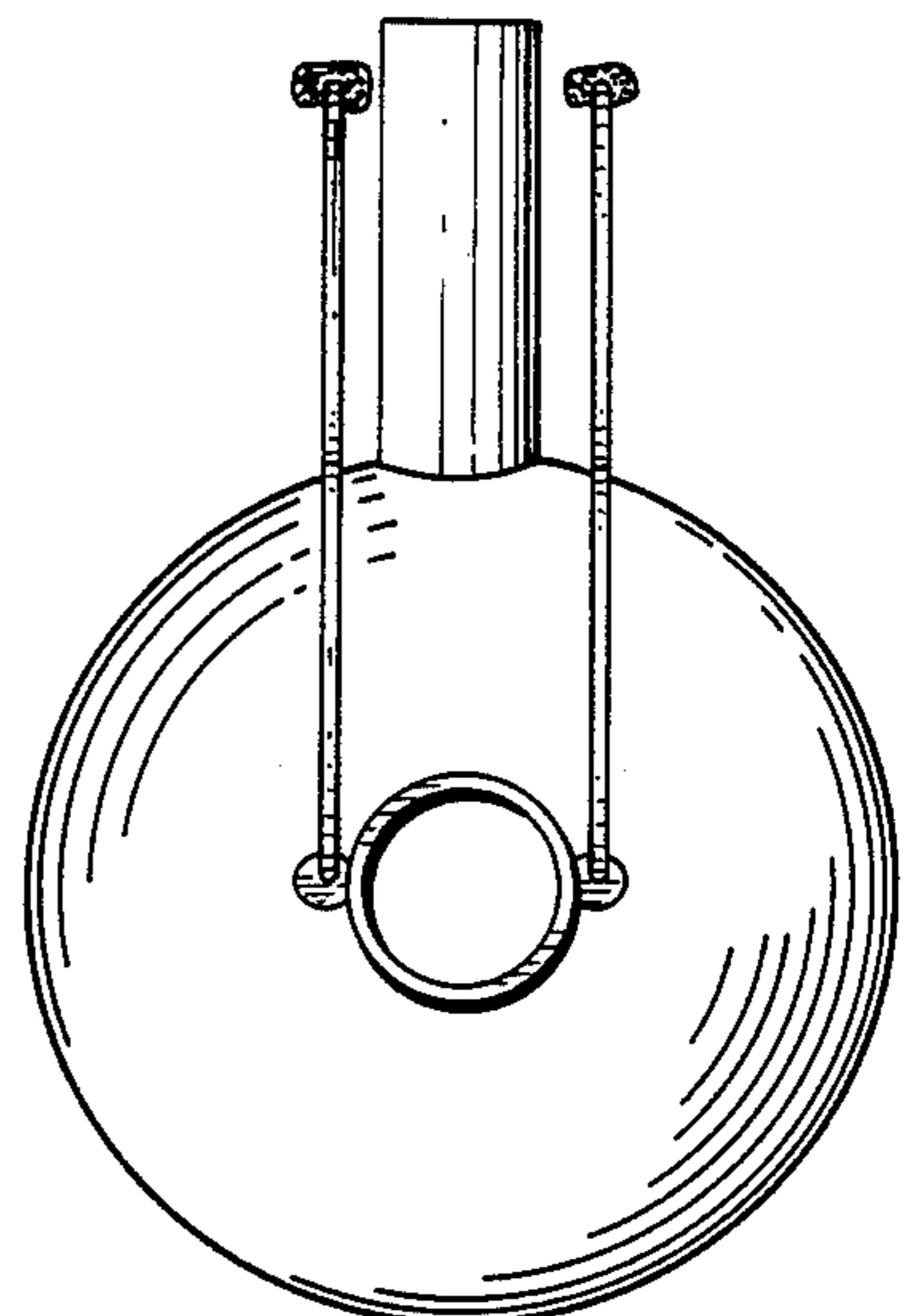

FIG. 3

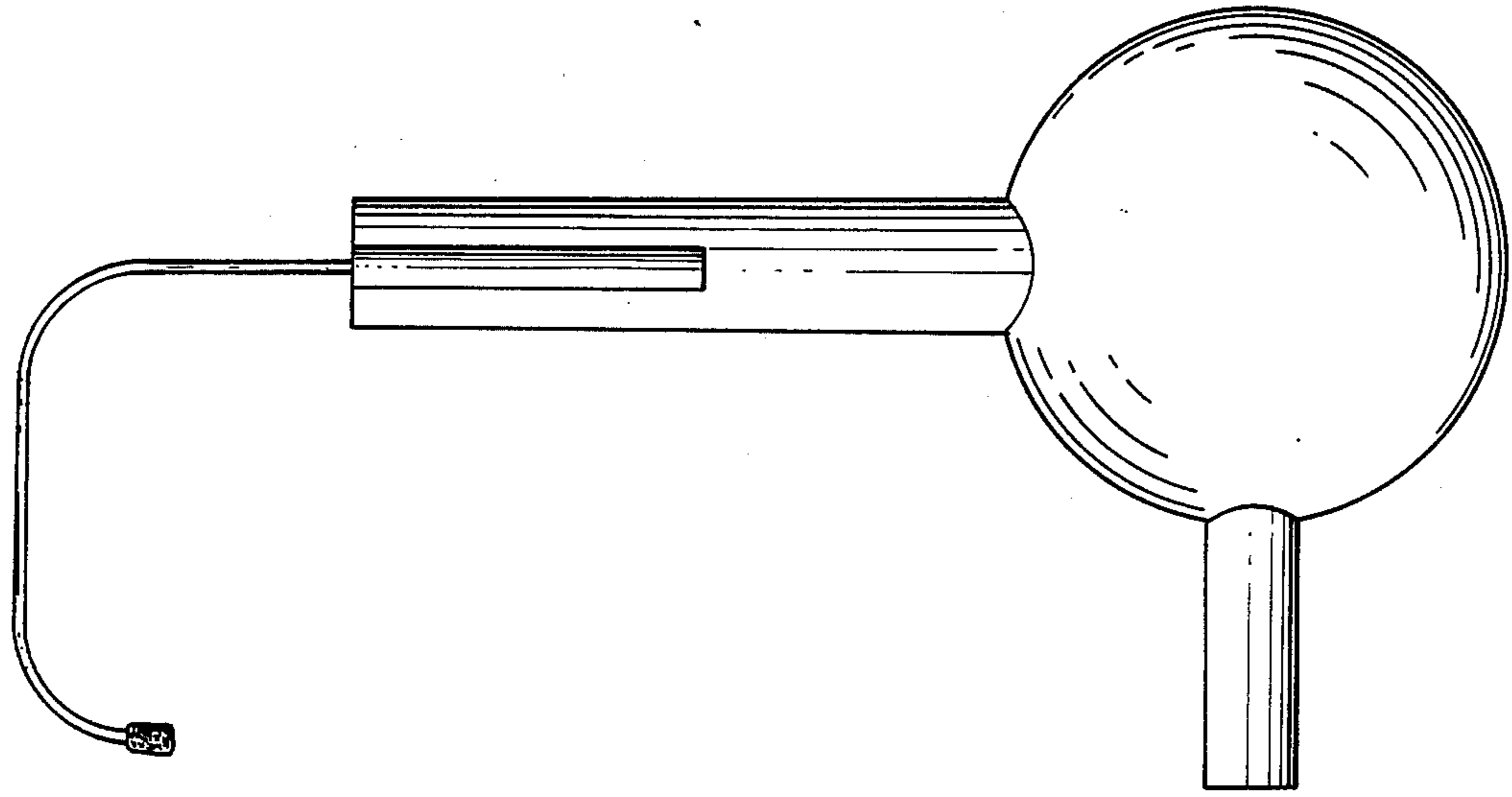

FIG. 6

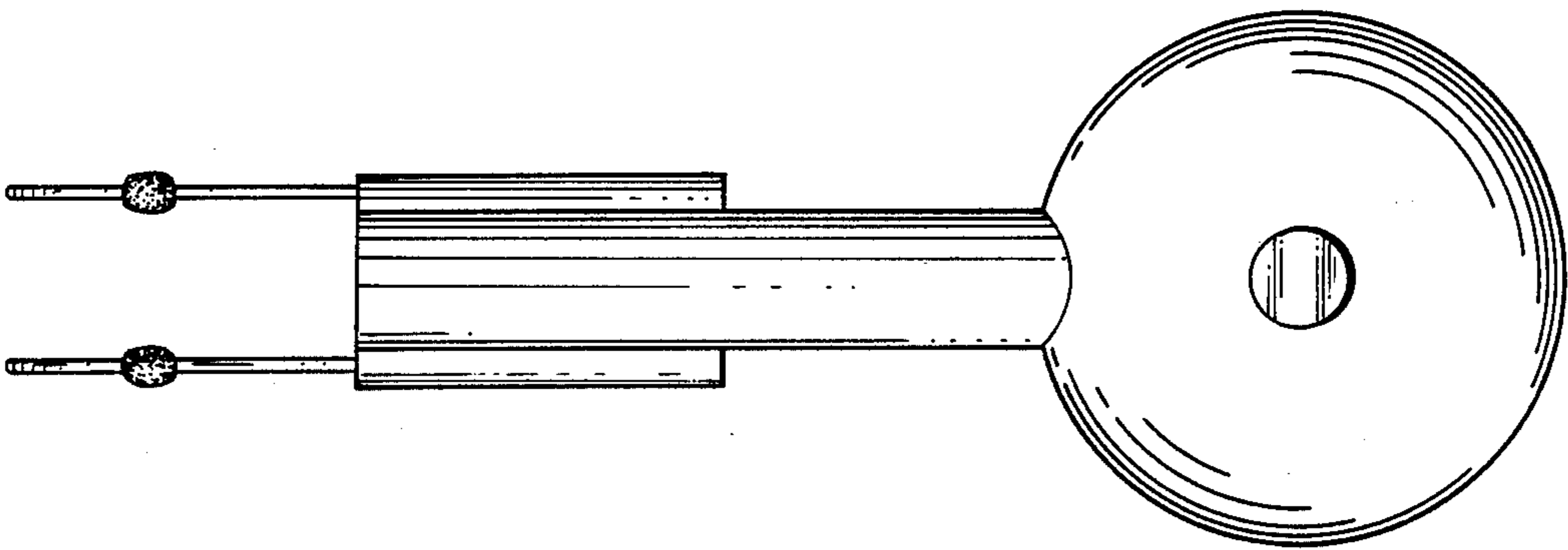

FIG. 5

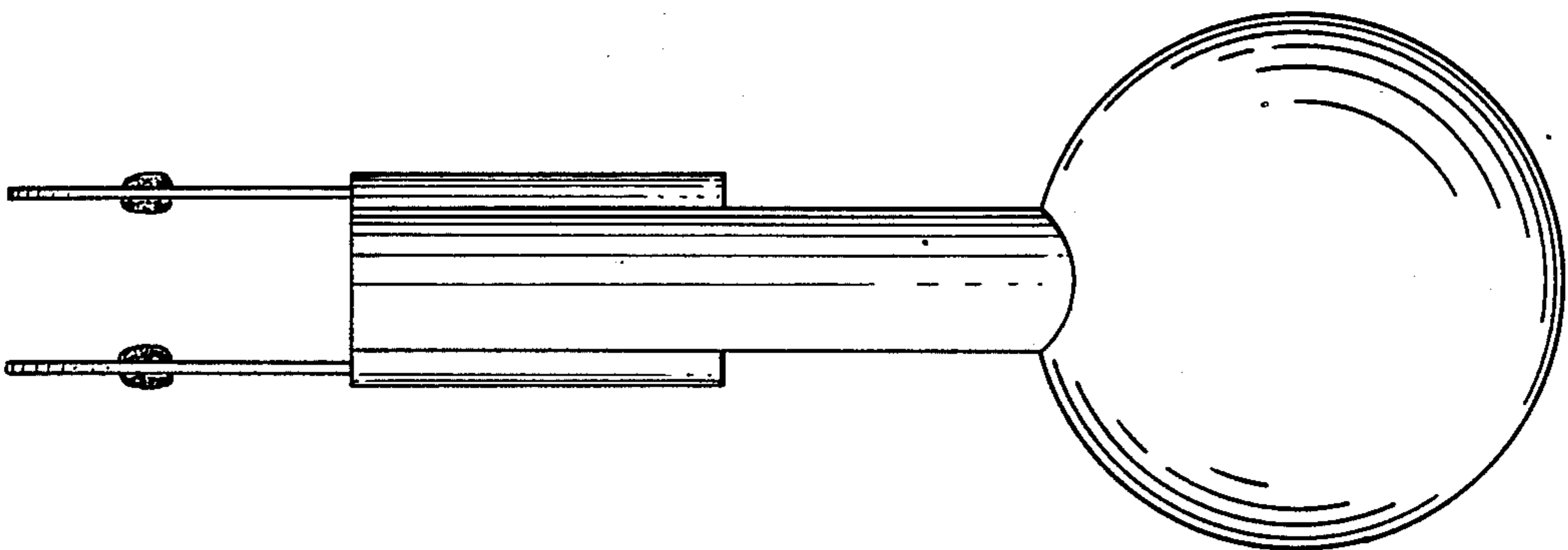

FIG. 4