

- [54] **CUTTING TOOL INSERT**
- [75] **Inventor:** Eugen Valerius, Alter Anspacher, Fed. Rep. of Germany
- [73] **Assignee:** Kennametal Inc., Latrobe, Pa.
- [**] **Term:** 14 Years
- [21] **Appl. No.:** 147,008
- [22] **Filed:** Jan. 22, 1988
- [52] **U.S. Cl.** D15/130; D15/139
- [58] **Field of Search** D15/138, 139, 140; 407/113, 114, 115, 116, 117, 42

[56] **References Cited**

U.S. PATENT DOCUMENTS

D. 280,514	9/1985	Porat et al.	D15/139
275,396	9/1884	Porat et al. .	
291,889	9/1887	Petterson et al. .	
3,636,602	1/1972	Owen	407/113
3,733,664	5/1973	McKelvey .	
3,792,514	2/1974	Ushijima	407/115 X
3,968,550	7/1976	Gehri	407/114
4,318,644	3/1982	Seidel	D15/139 X
4,318,645	3/1982	McCreery .	
4,340,324	7/1982	McCreery .	
4,359,300	11/1982	Hazra et al.	407/114
4,411,565	10/1983	Hazra et al.	407/114
4,507,024	3/1985	Stasko	407/114
4,685,844	8/1987	McCreery et al. .	
4,741,649	5/1988	Mori	407/114
4,787,784	11/1988	Bernadi et al.	407/114

FOREIGN PATENT DOCUMENTS

0046511	2/1982	European Pat. Off. .
2252350	5/1973	Fed. Rep. of Germany .
52-35380	3/1977	Japan .

OTHER PUBLICATIONS

"Sandvik Coromant's New Turning Generation," an advertisement, dated 1987.

"Chip Control Inserts," an advertisement of Kennametal Inc., published Feb. 1987.

Primary Examiner—Bruce W. Dunkins
Assistant Examiner—Jeffrey Asch
Attorney, Agent, or Firm—Thomas R. Trempus

[57] **CLAIM**

The ornamental design for a cutting tool insert, as shown and described.

DESCRIPTION

FIG. 1 is a top and left side perspective view of a cutting tool insert showing my new design;
 FIG. 2 is a top plan view;
 FIG. 3 is a right side elevational view;
 FIG. 4 is a bottom plan view;
 FIG. 5 is a cross sectional view taken along line 5—5 in FIG. 2;
 FIG. 6 is a top and left side perspective view showing a second embodiment of that shown in FIGS. 1-5;
 FIG. 7 is a top plan view;
 FIG. 8 is a right side elevational view;
 FIG. 9 is a bottom plan view;
 FIG. 10 is a cross sectional view taken along line 10—10 in FIG. 7;
 FIG. 11 is a top and left side perspective view showing a third embodiment of that shown in FIGS. 1-5;
 FIG. 12 is a top plan view;
 FIG. 13 is a right side elevational view;
 FIG. 14 is a bottom plan view;
 FIG. 15 is a cross sectional view taken along line 15—15 in FIG. 12;
 FIG. 16 is a top and left side perspective view showing a fourth embodiment of that shown in FIGS. 1-5;
 FIG. 17 is a top plan view;
 FIG. 18 is a right side elevational view;
 FIG. 19 is a bottom plan view; and
 FIG. 20 is a cross-sectional view, taken along line 20—20 in FIG. 17, thereof.

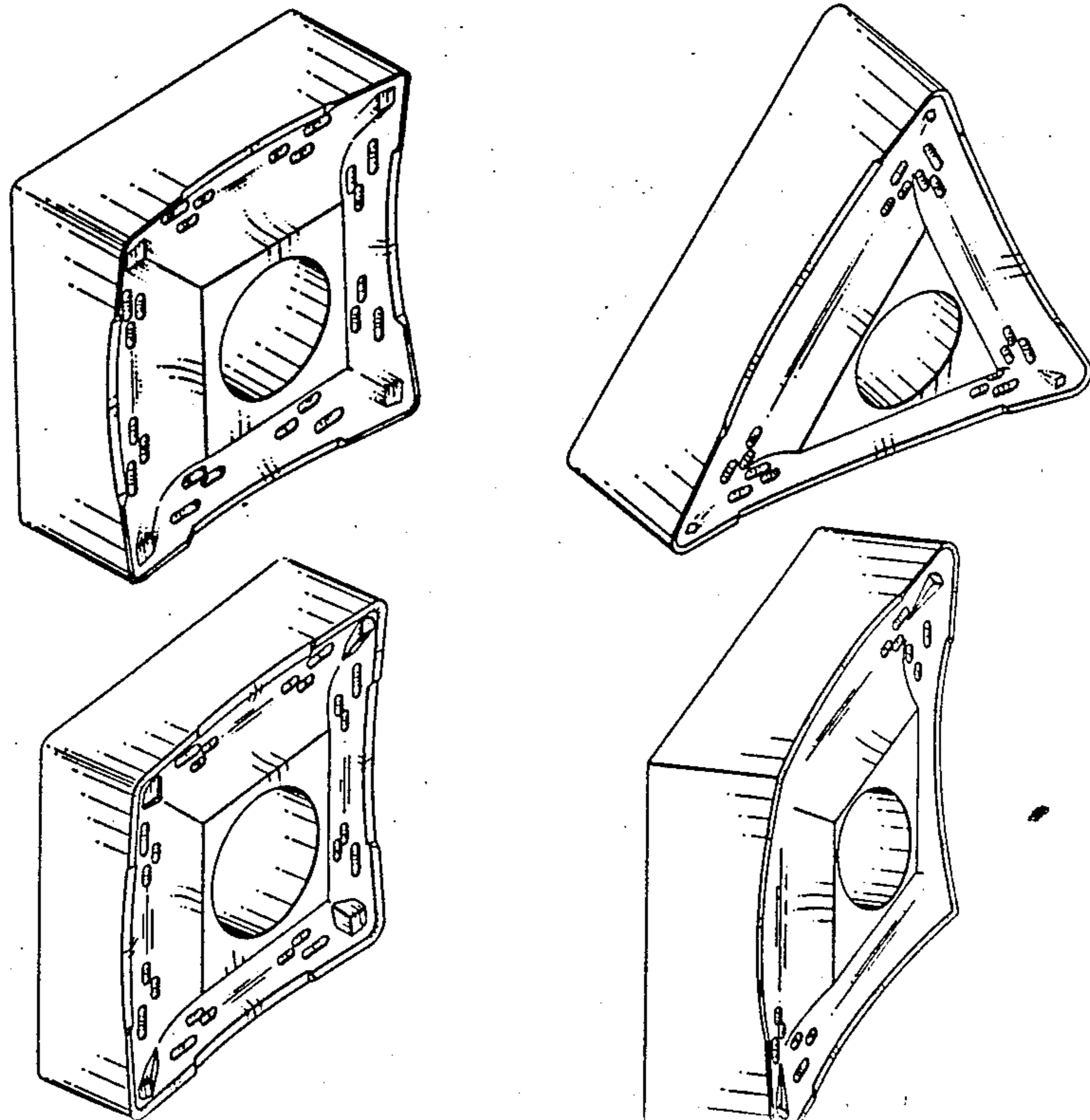

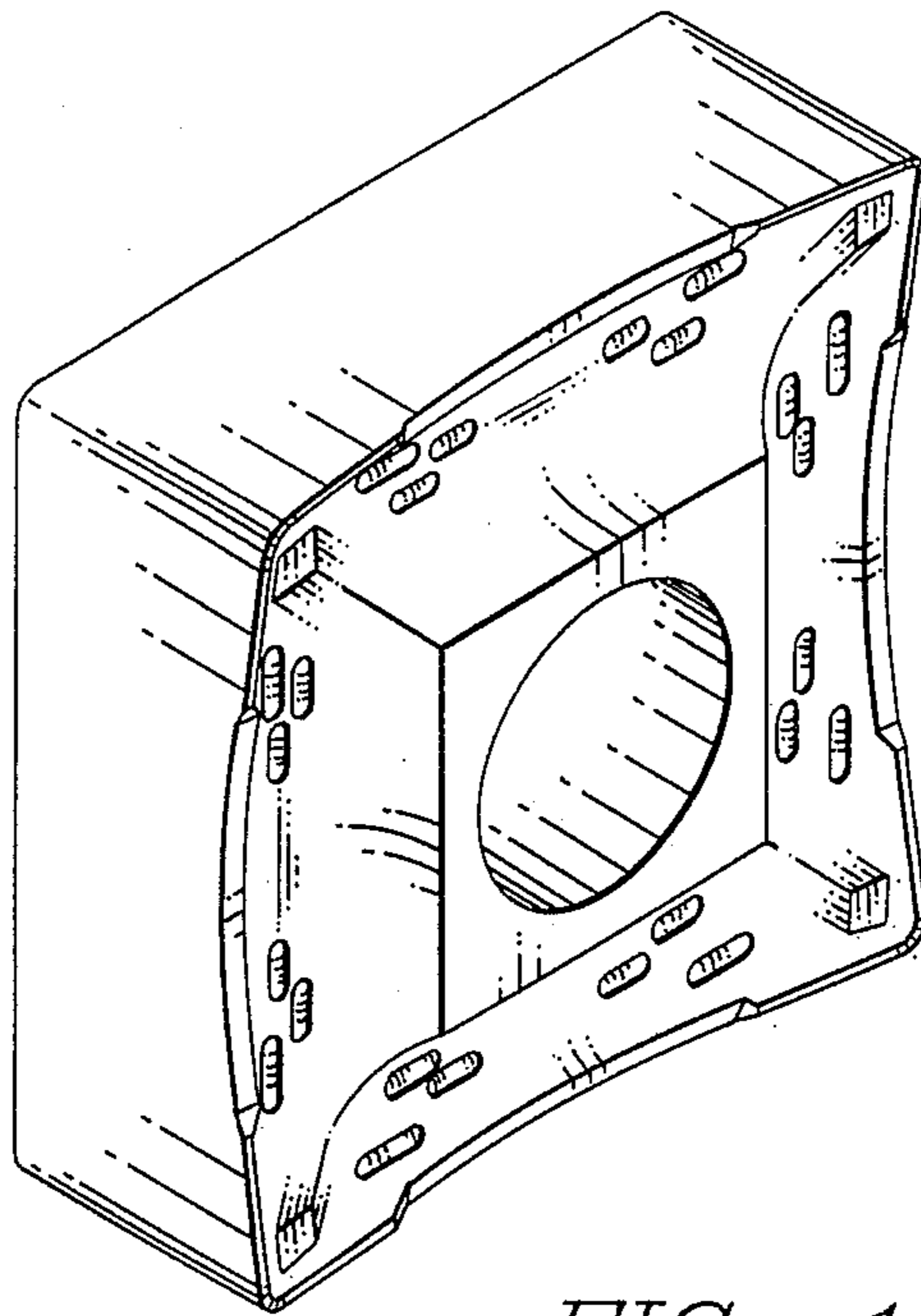

FIG. 1

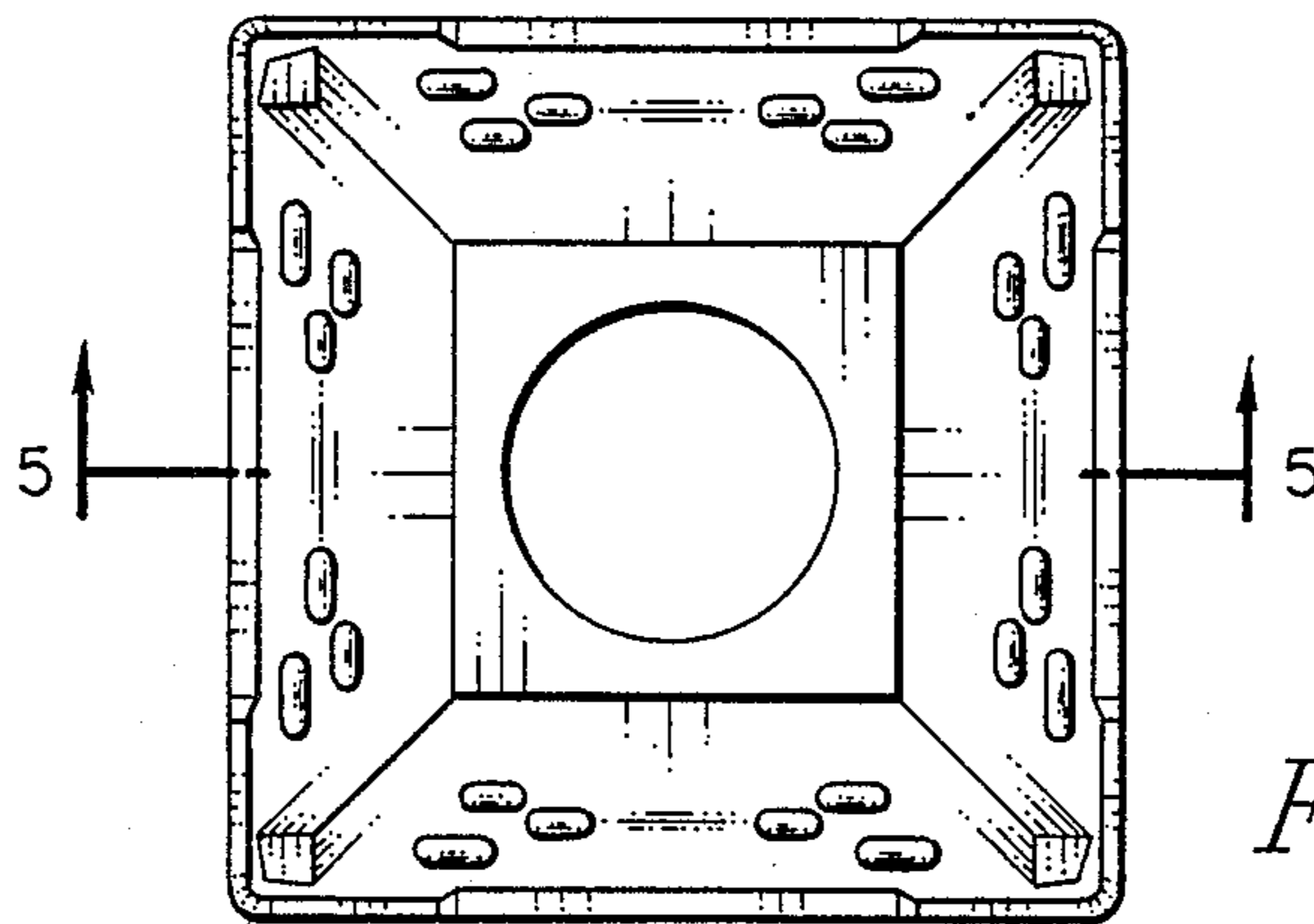

FIG. 2

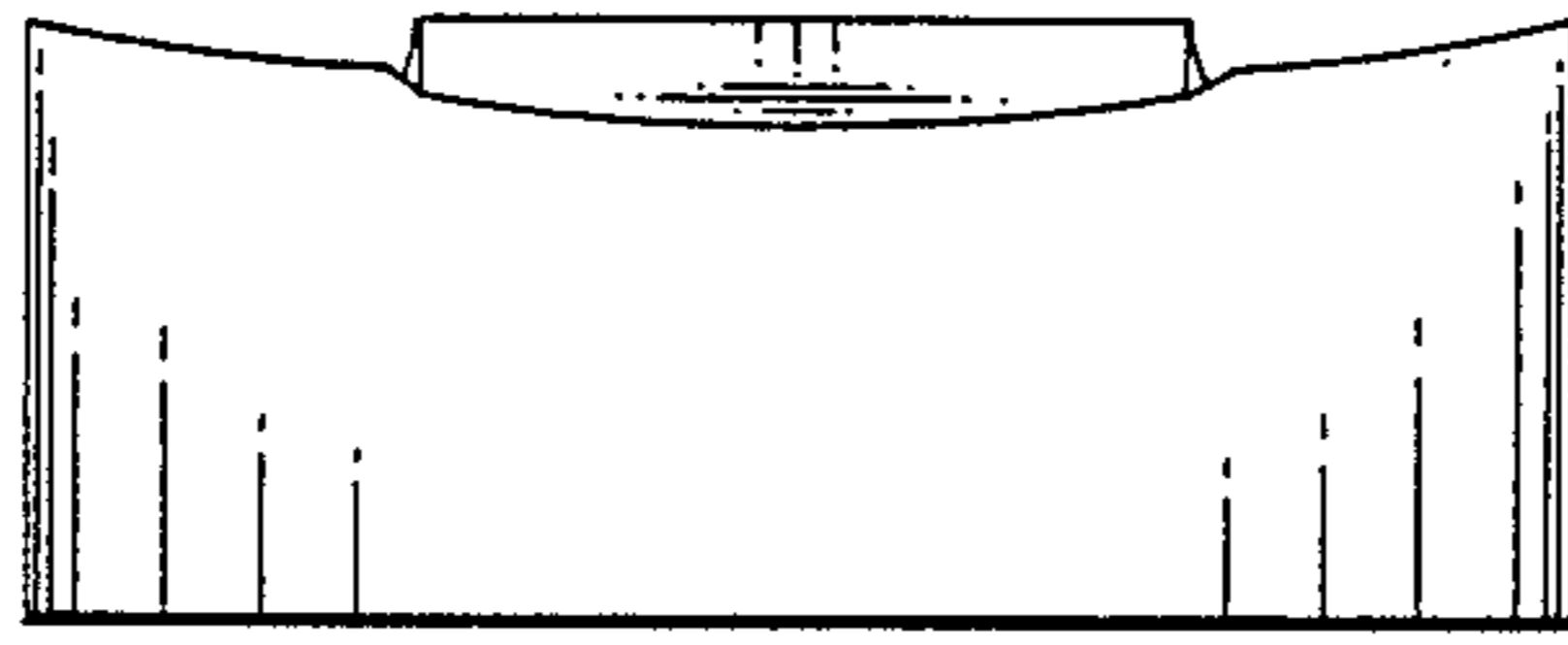

FIG. 3

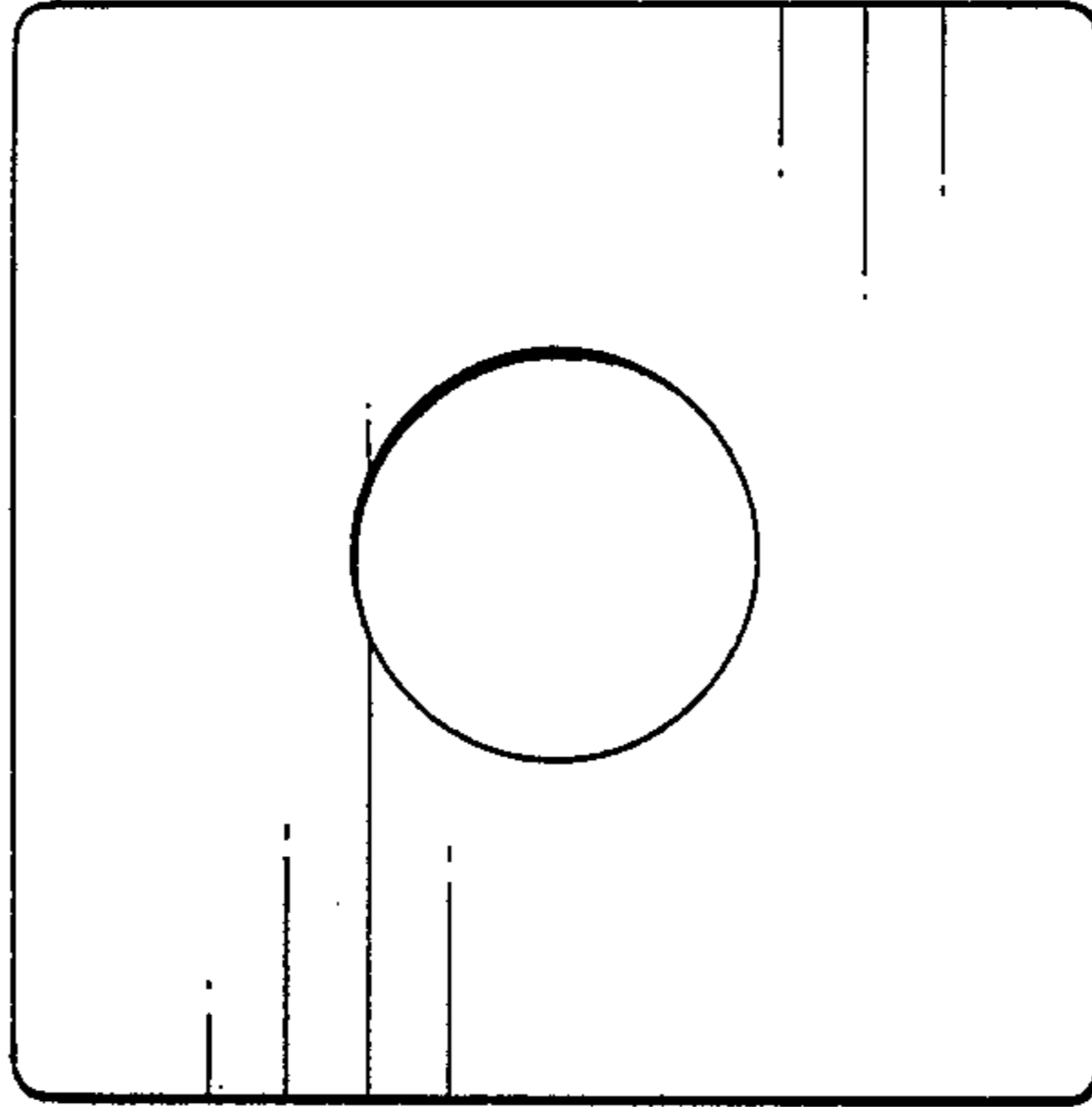

FIG. 4

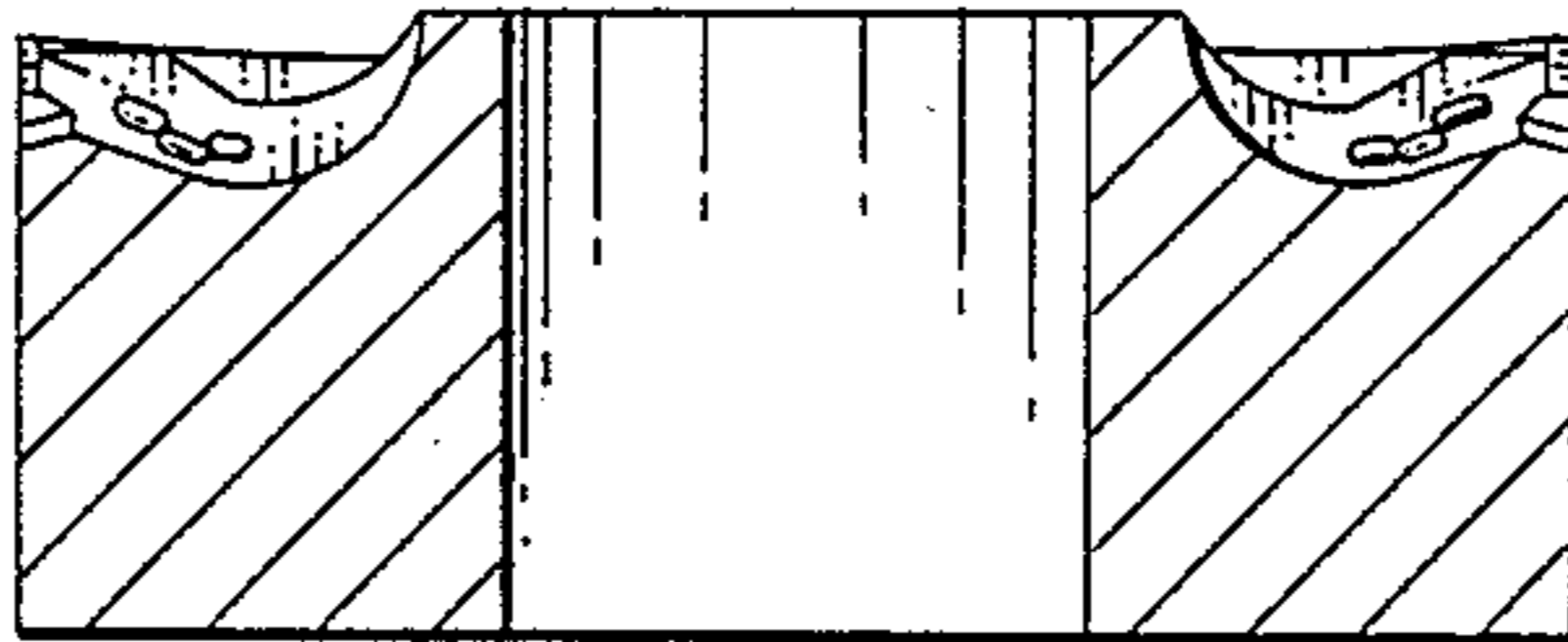

FIG. 5

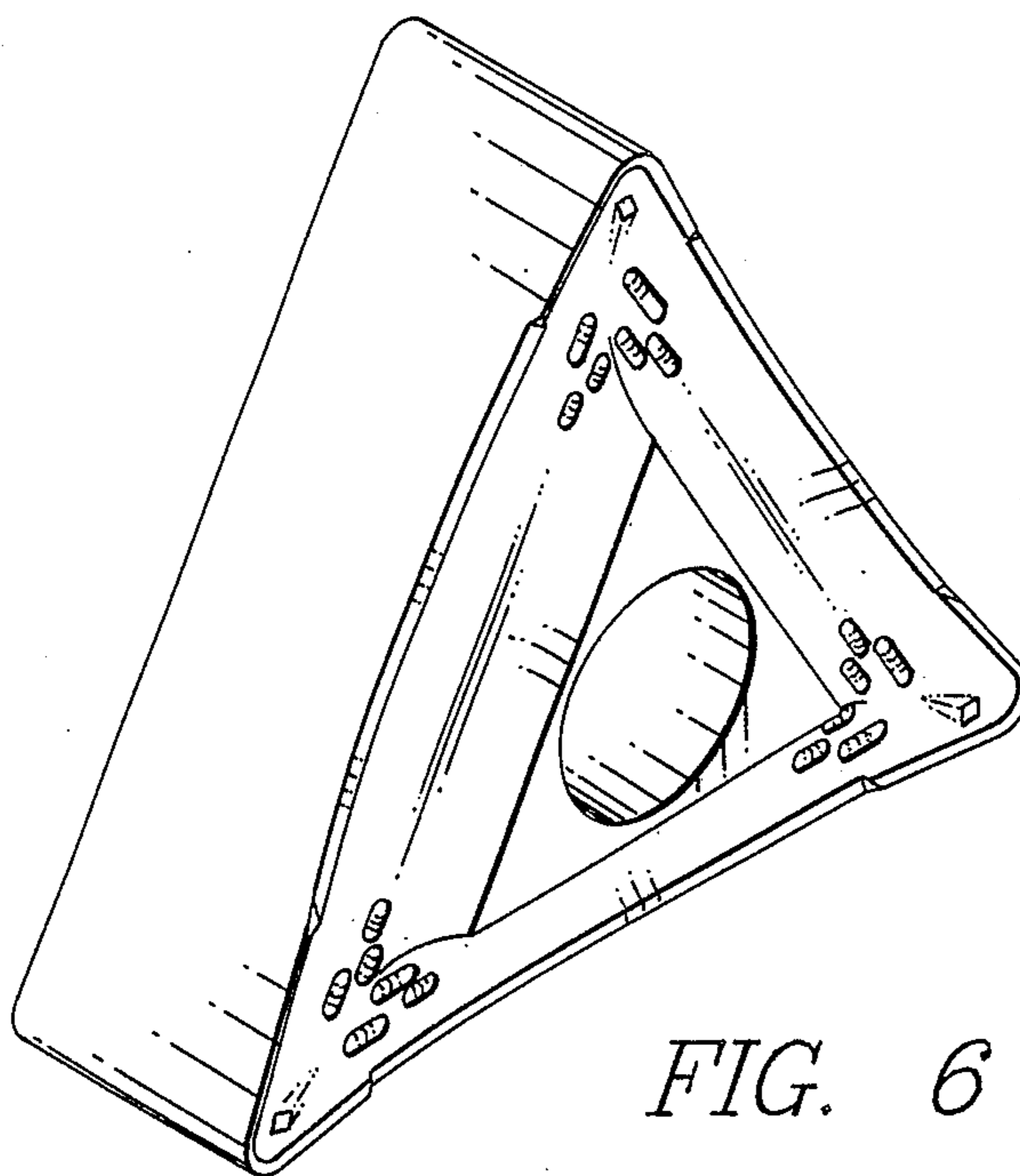

FIG. 6

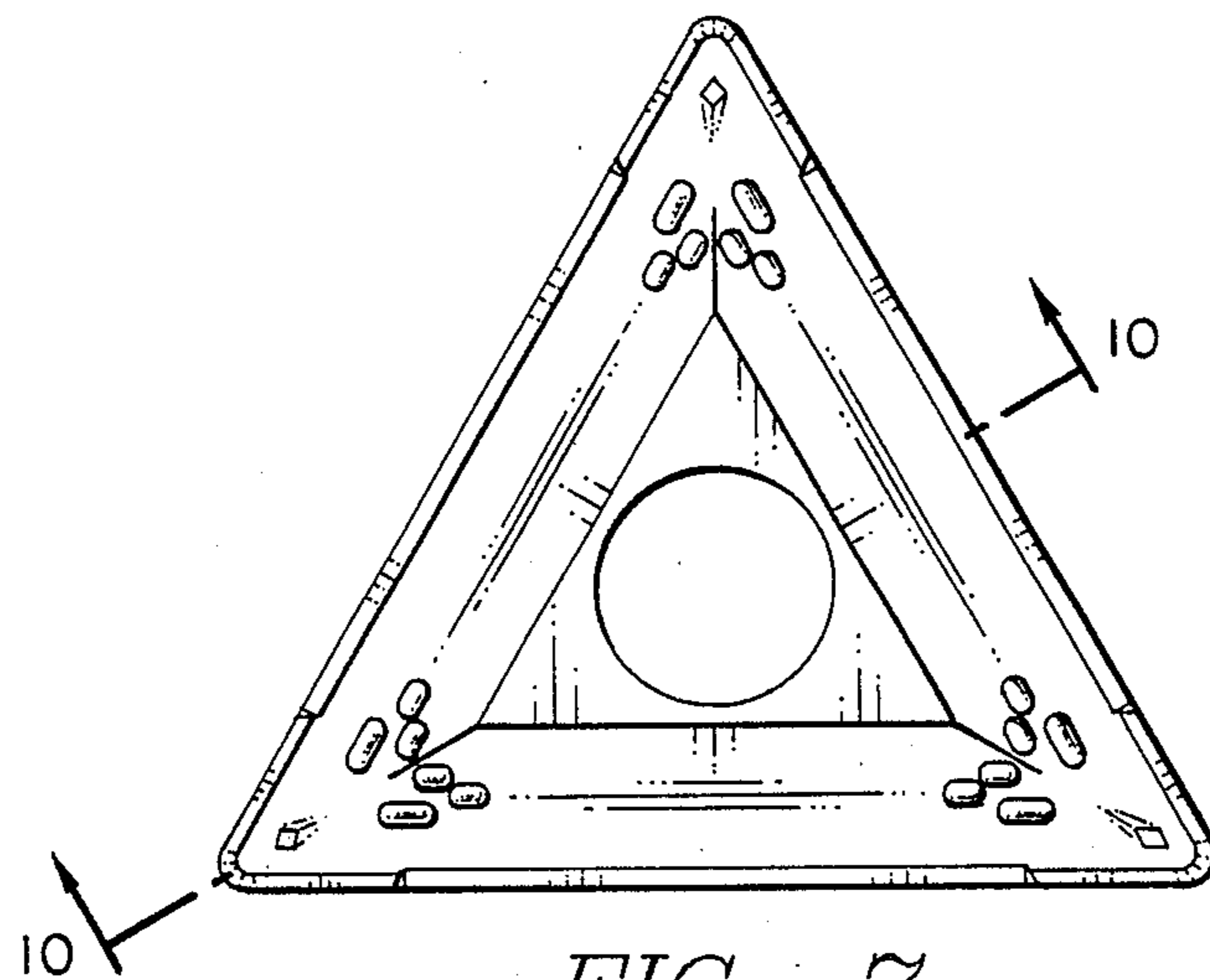

FIG. 7

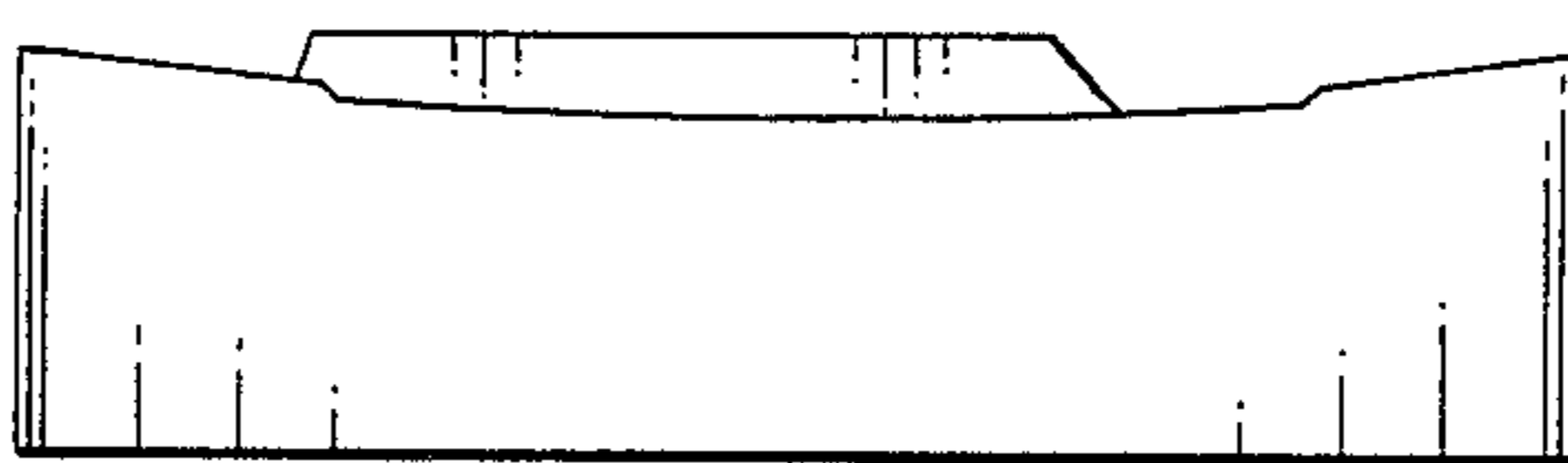

FIG. 8

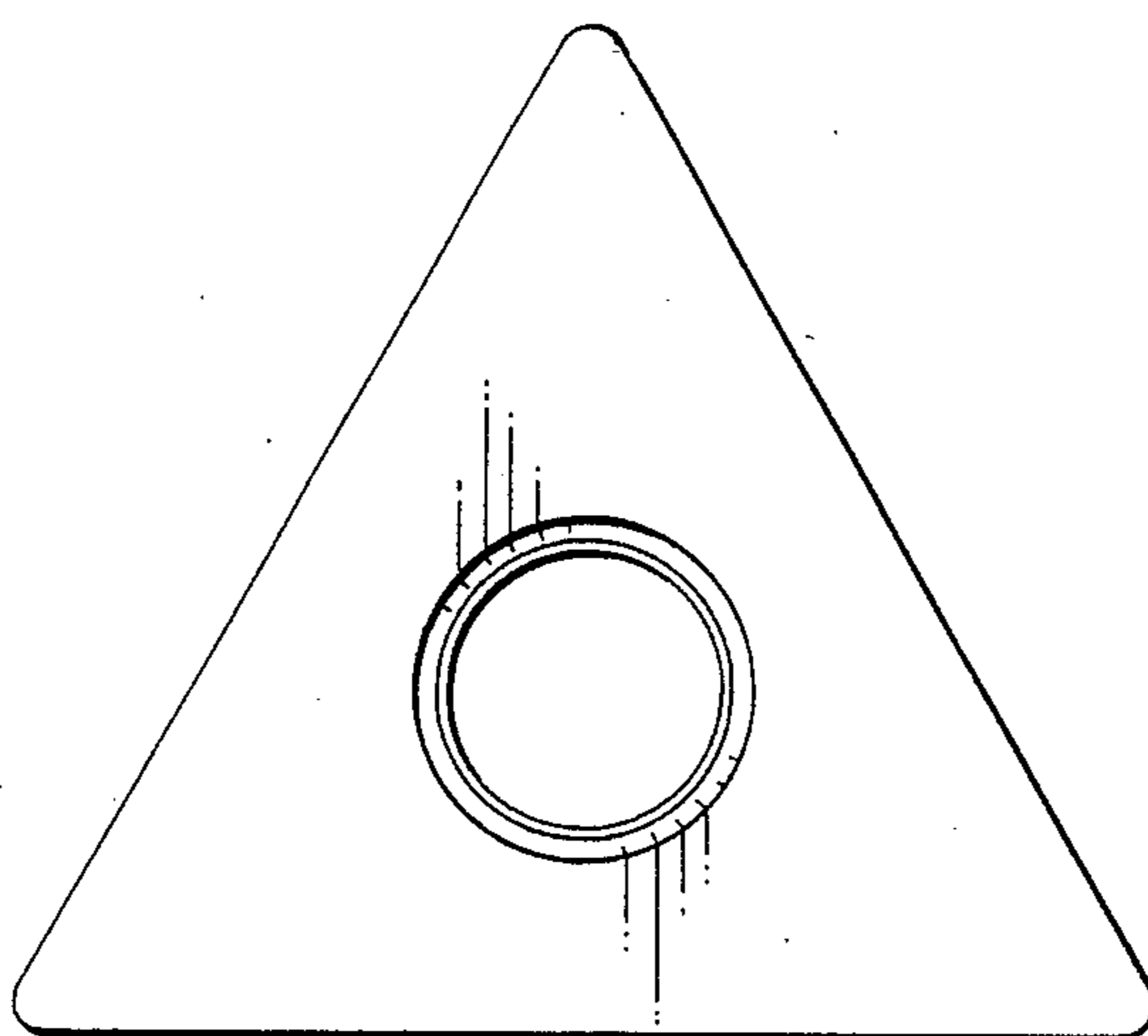

FIG. 9

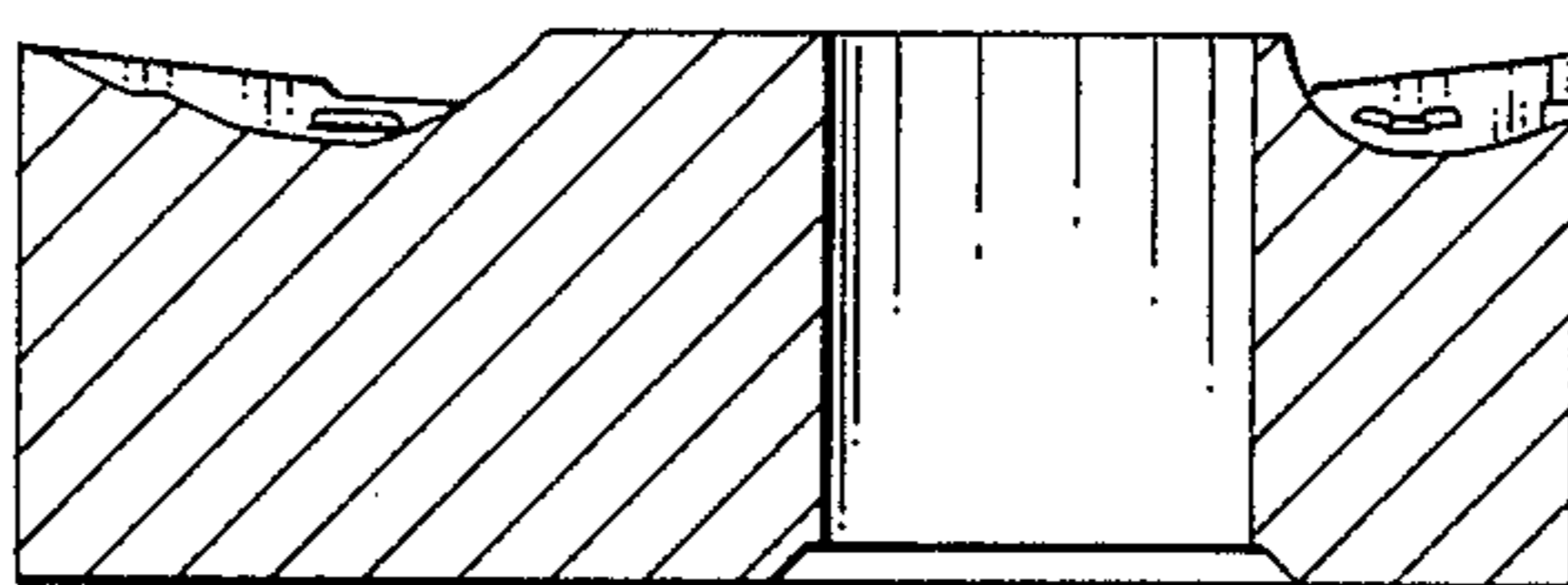

FIG. 10

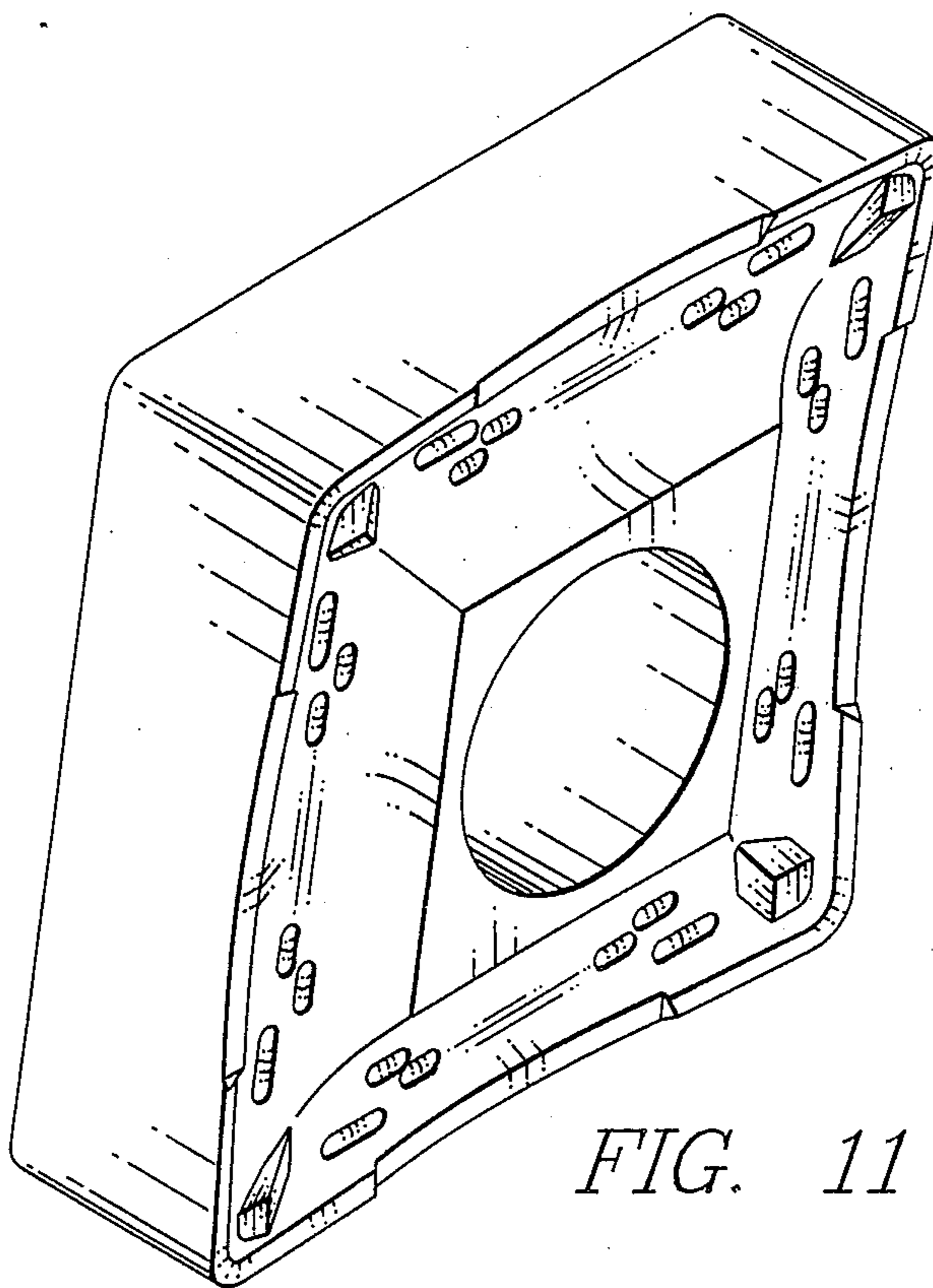

FIG. 11

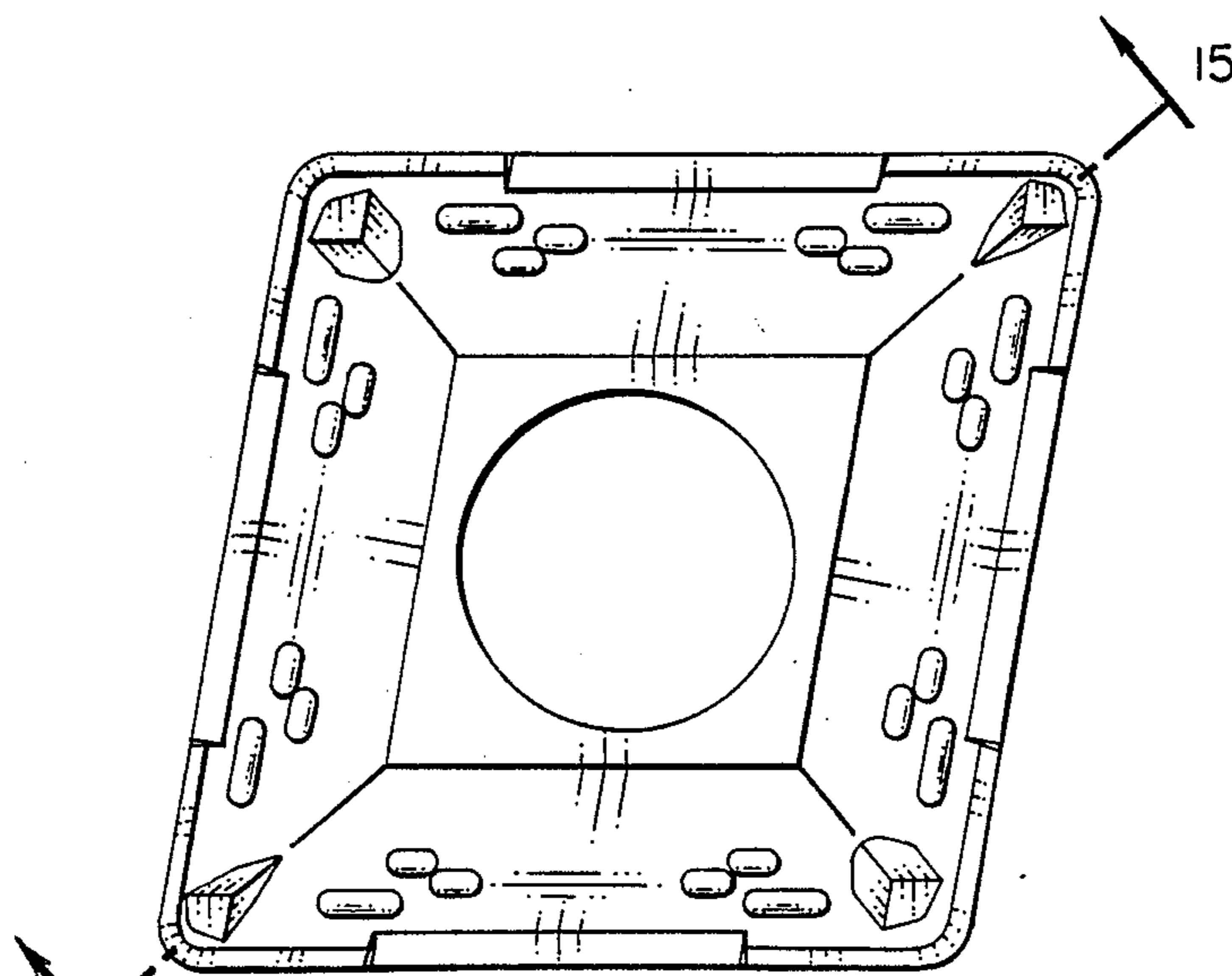

FIG. 12

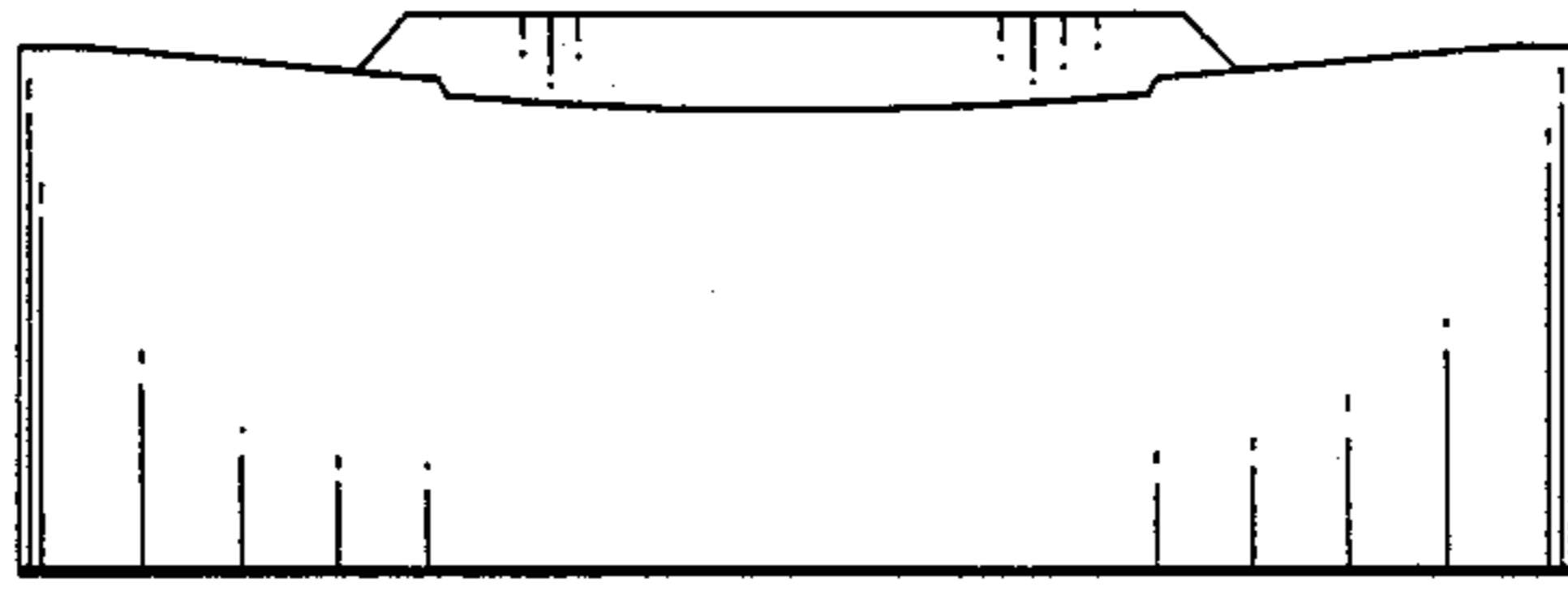

FIG. 13

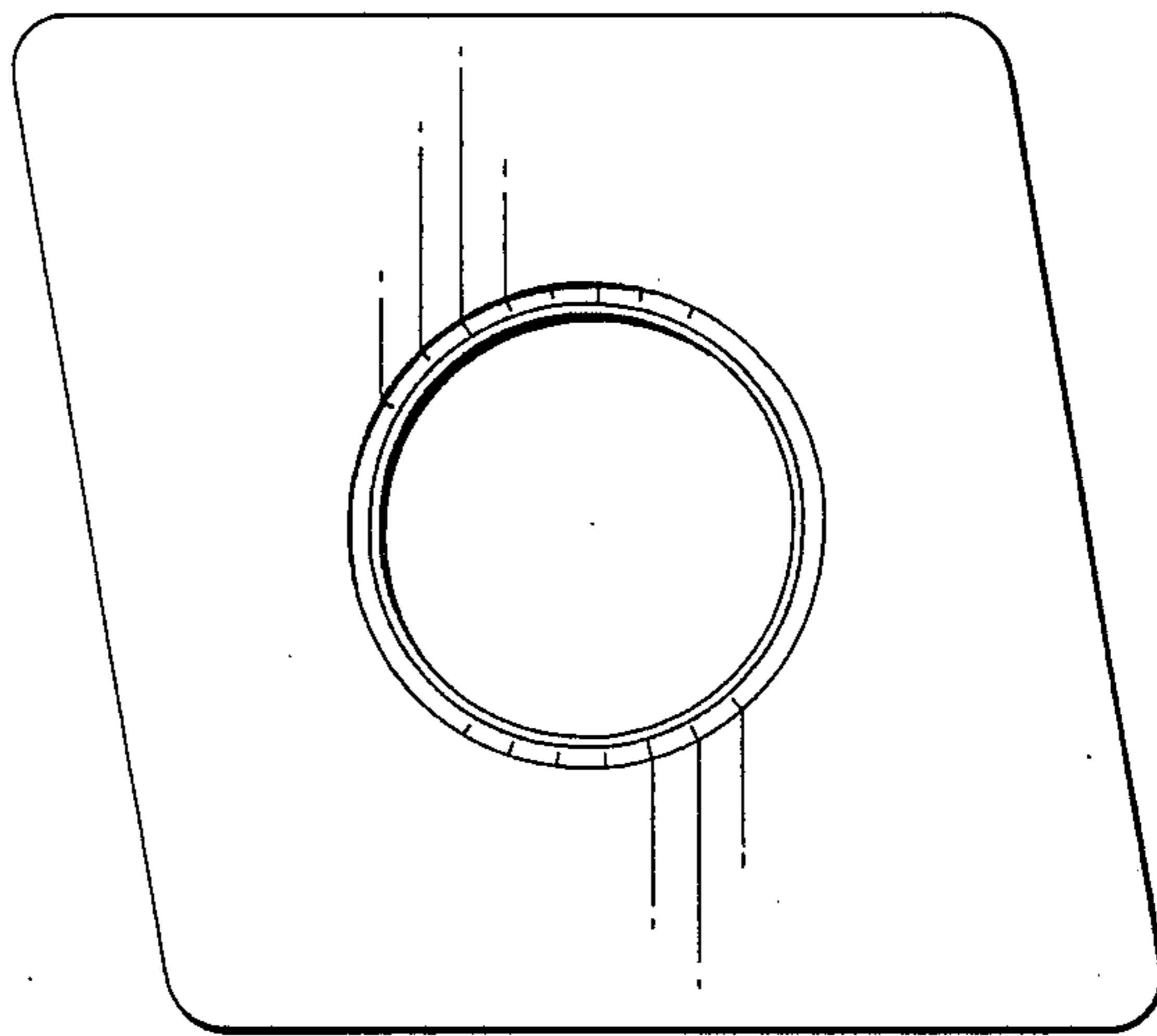

FIG. 14

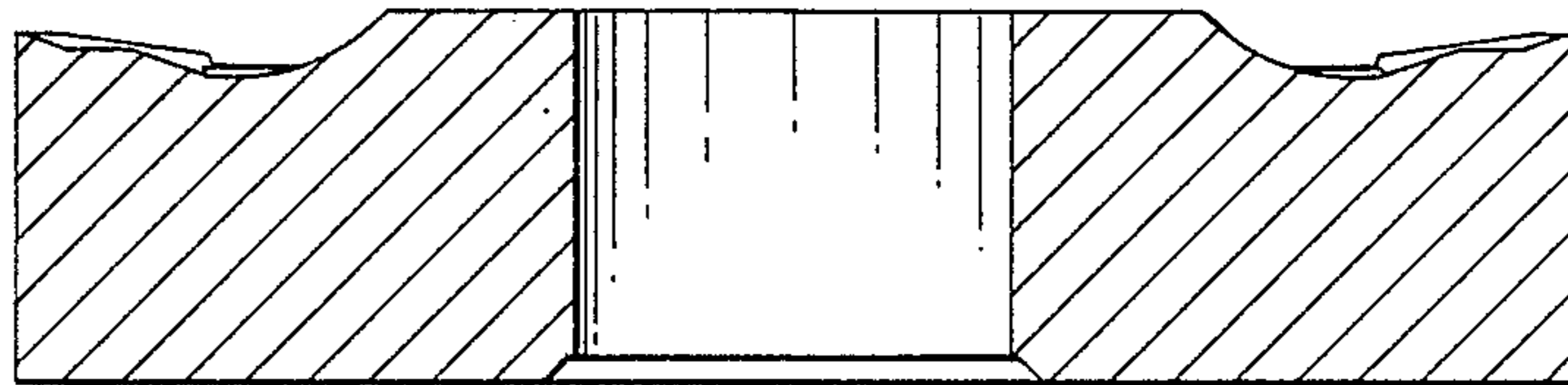

FIG. 15

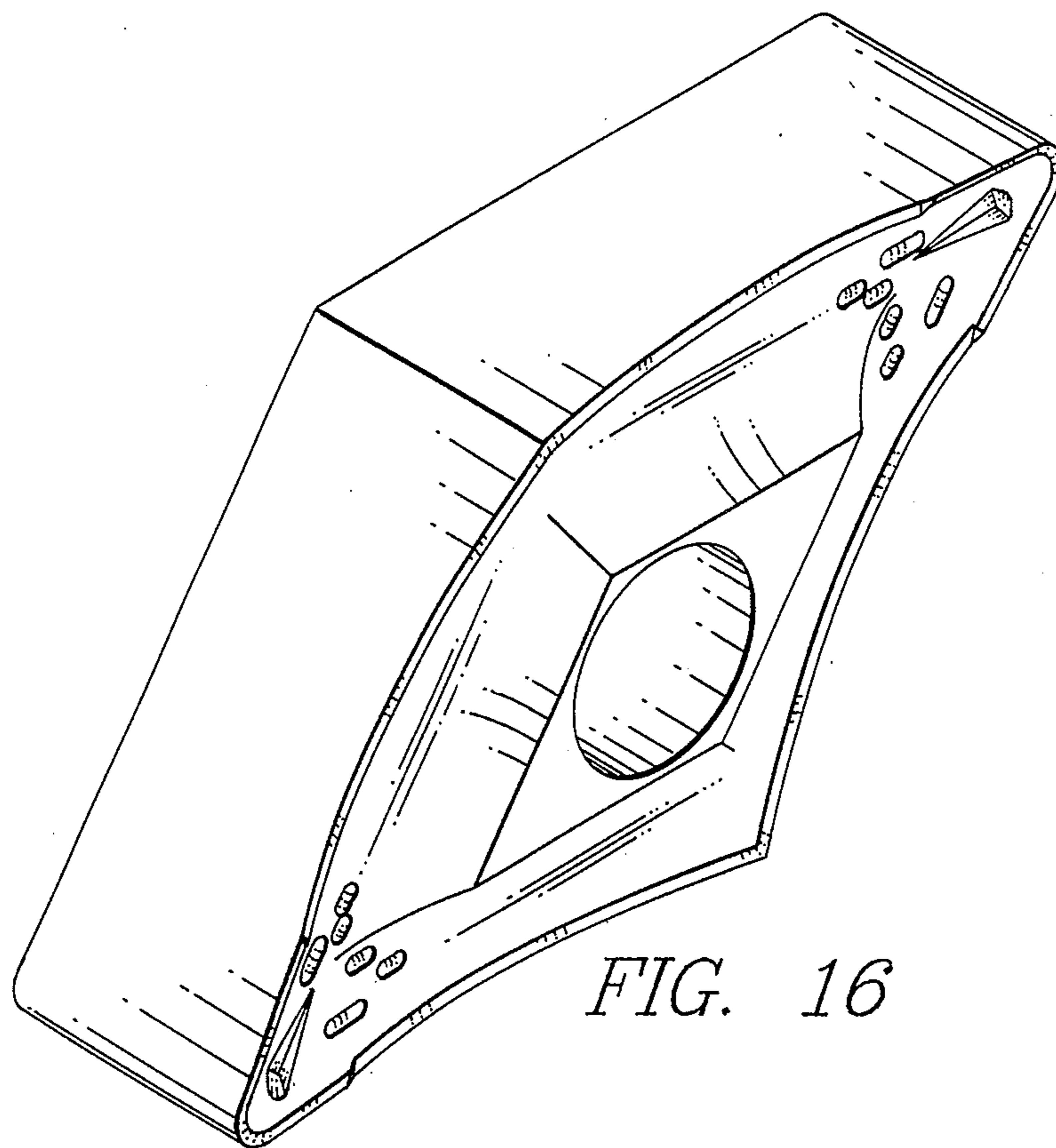

FIG. 16

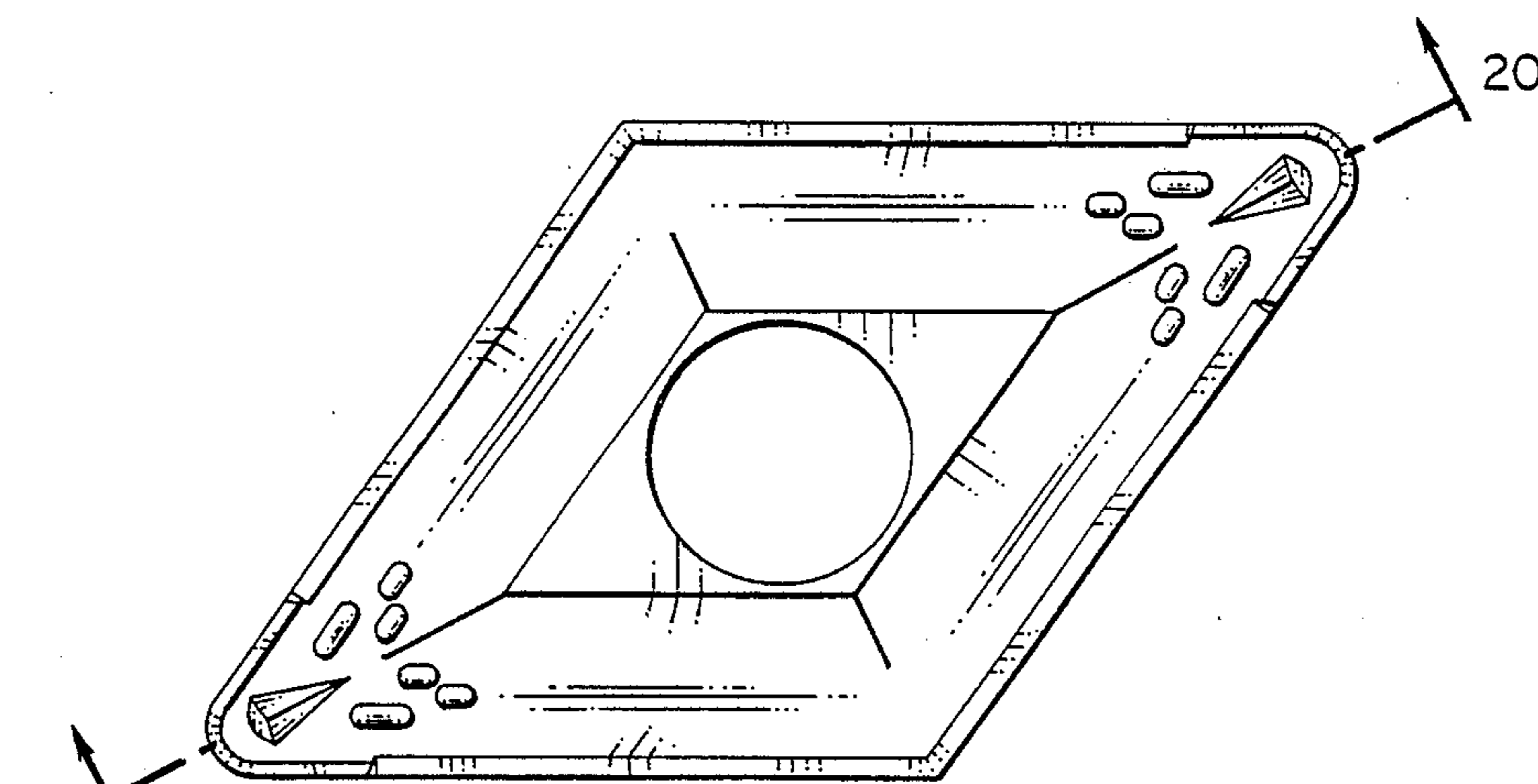

FIG. 17

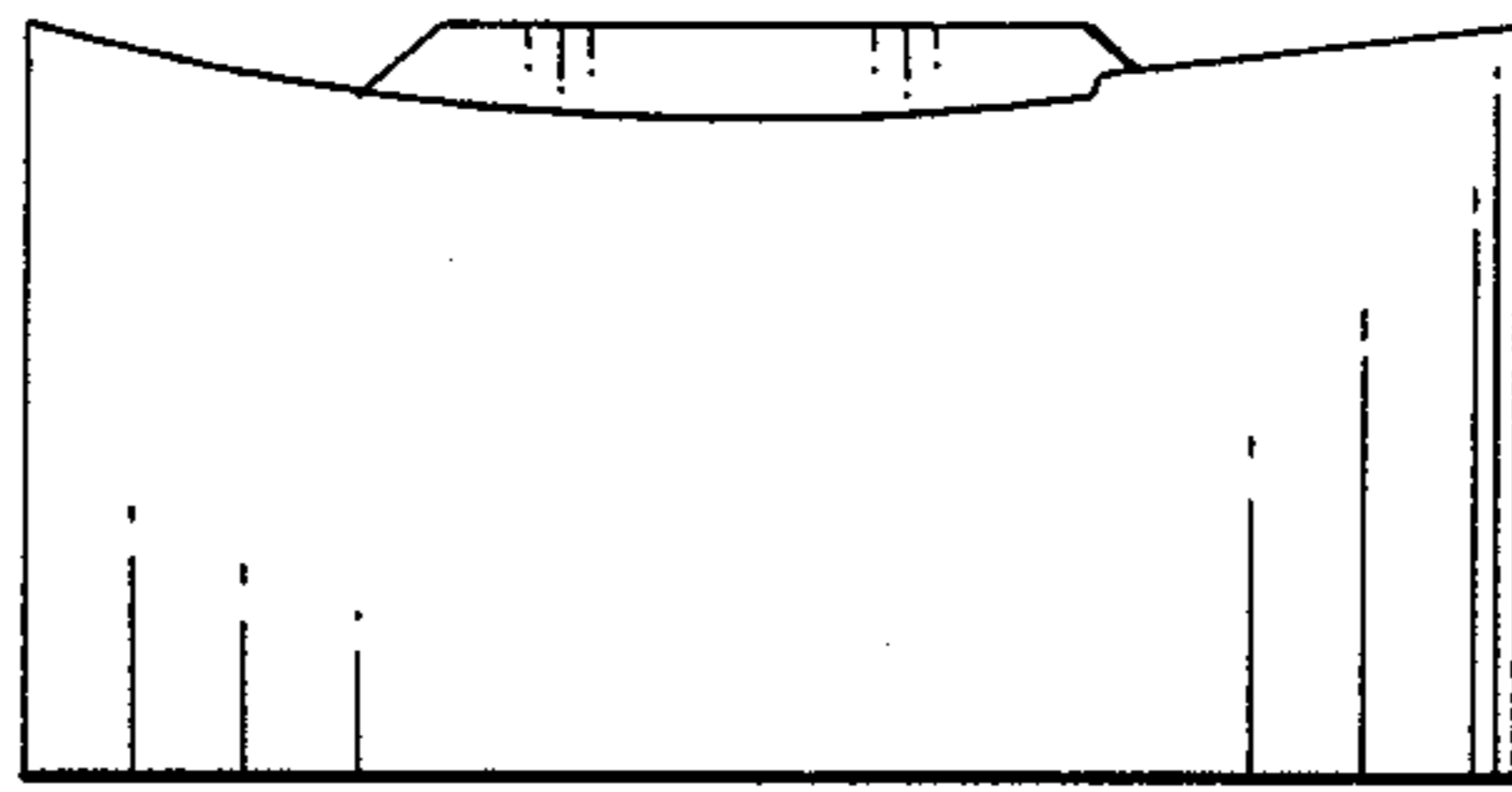

FIG. 18

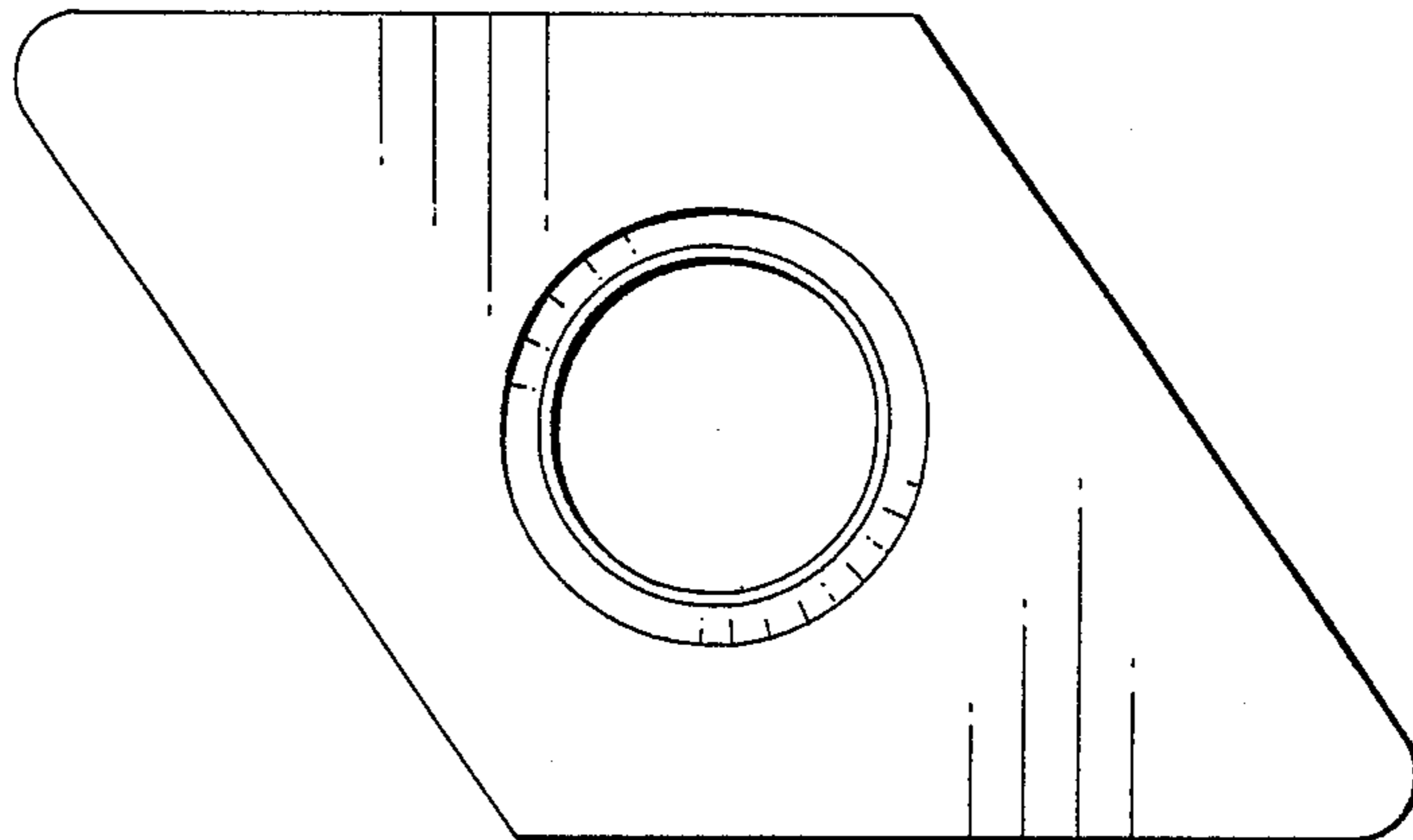

FIG. 19

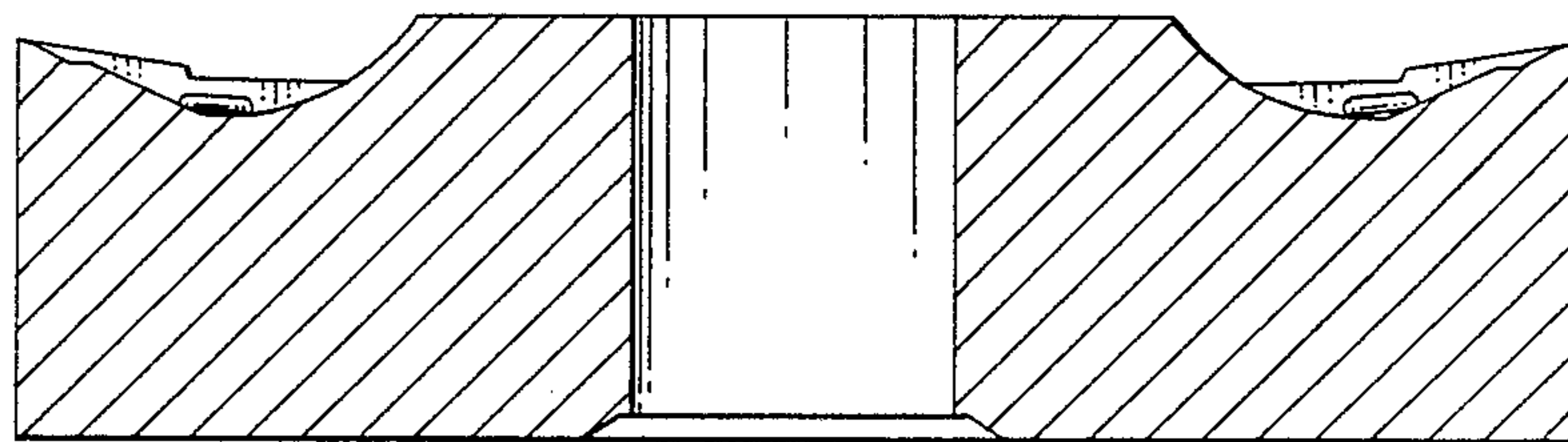

FIG. 20