

[54] ELECTRIC ROBOT

[56] References Cited

U.S. PATENT DOCUMENTS

[75] Inventors: Gary L. Jones, Madison Heights; Robert J. Todd, Milford Township, Oakland County; Norman N. Fender, Hudson; Dale A. Wood, Canton, all of Mich.; Alexander Bally, Carnegie, Pa.

D. 268,033	2/1983	Stackhouse .....	D15/199
D. 279,571	7/1985	Arai et al. ....	D15/199
D. 280,102	8/1985	Hicks .....	D15/199
D. 280,203	8/1985	Shibayama et al. ....	D15/199
D. 287,368	12/1986	Shibayama et al. ....	D15/199
D. 300,935	5/1989	Maddock et al. ....	D15/199

Primary Examiner—Carmen H. Vales-Lado  
Assistant Examiner—Jeffrey Asch

[73] Assignee: Graco Inc., Minneapolis, Minn.

[57] CLAIM

[\*\*] Term: 14 Years

The ornamental design for the electric robot, as shown and described.

[21] Appl. No.: 106,706

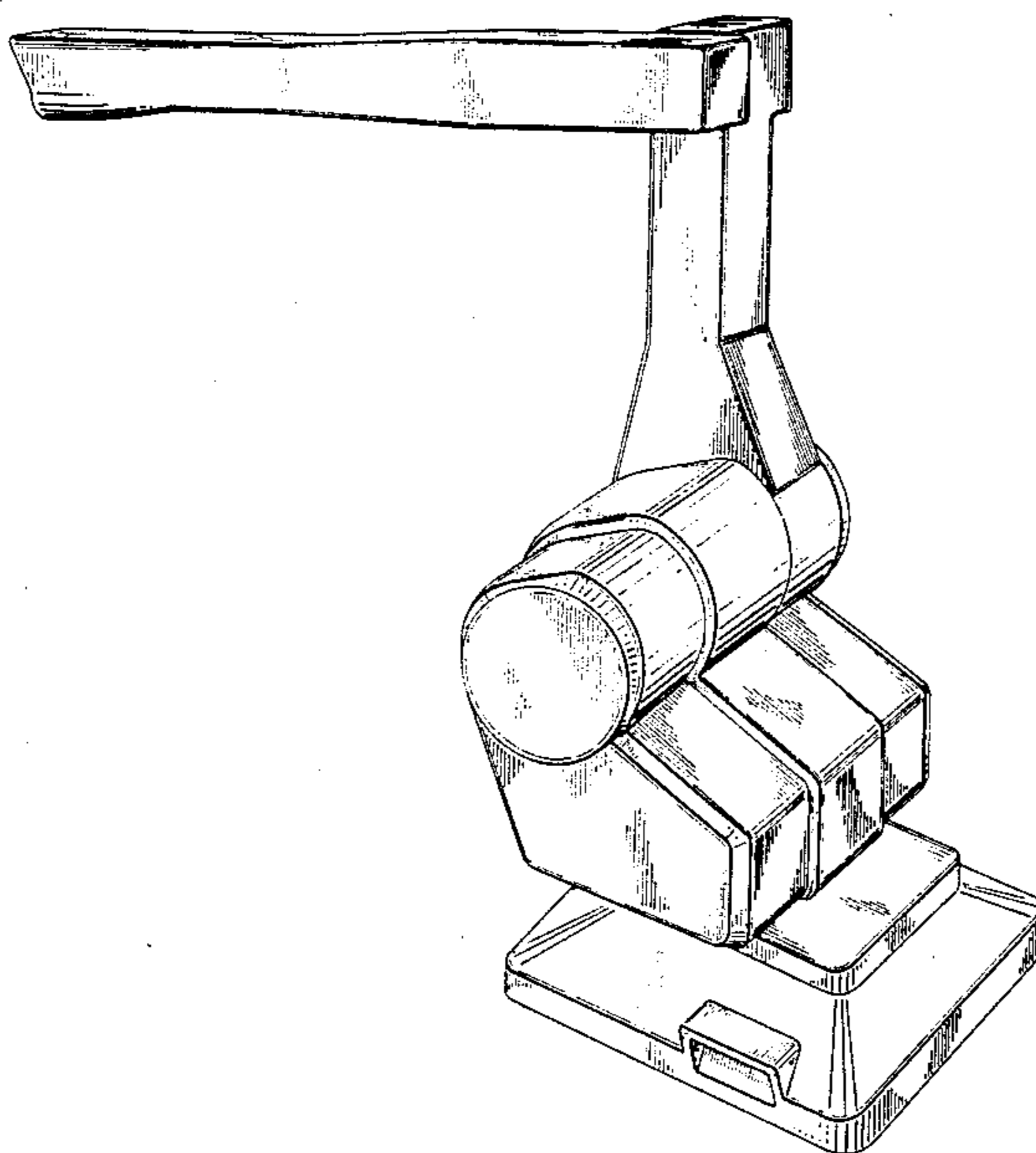
DESCRIPTION

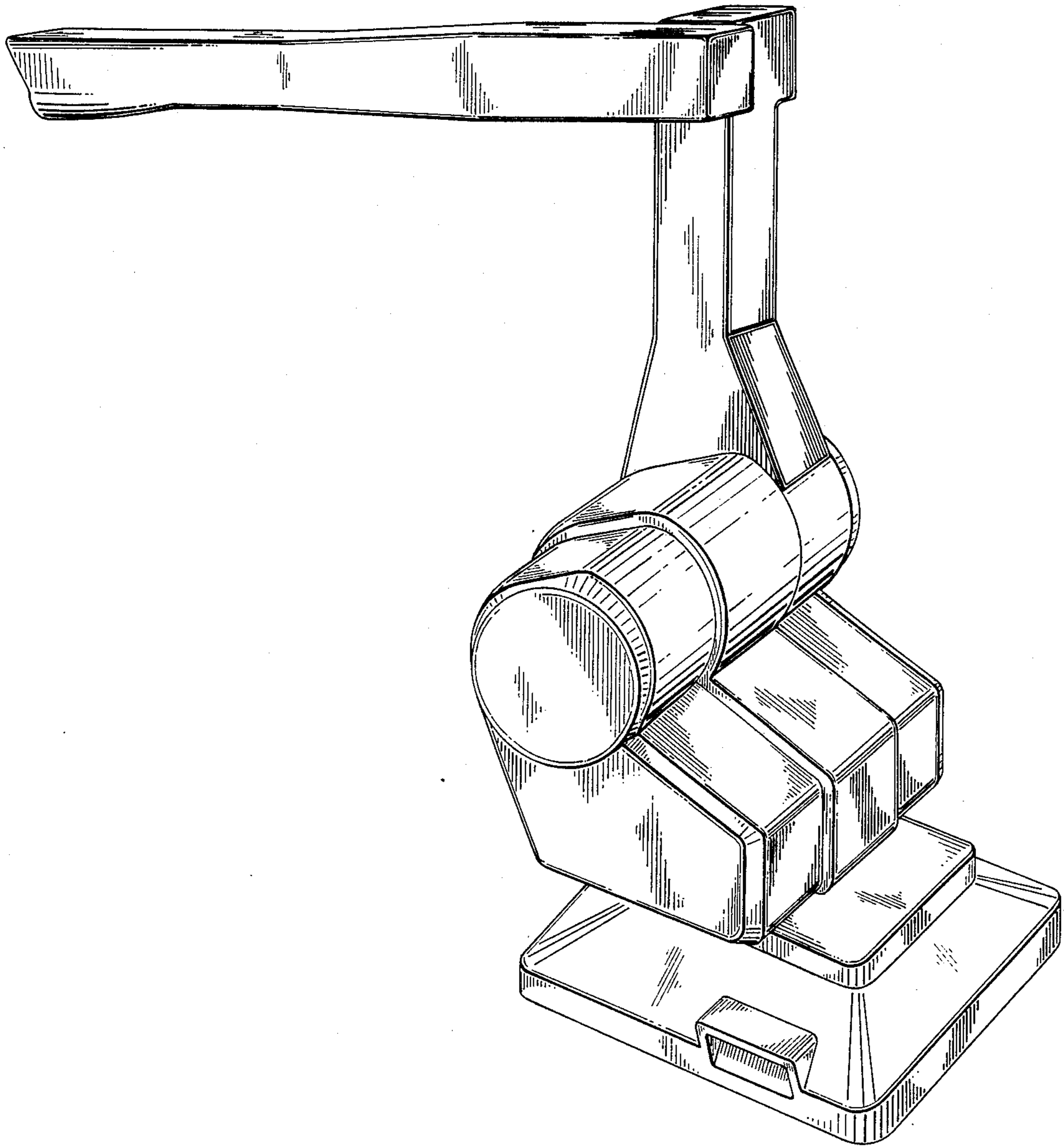
[22] Filed: Oct. 6, 1987

FIG. 1 is a right side perspective view of an electric robot showing our design;  
FIG. 2 is a front elevational view;  
FIG. 3 is a left side elevational view;  
FIG. 4 is a right side elevational view;  
FIG. 5 is a top plan view; and  
FIG. 6 is a rear elevational view thereof.

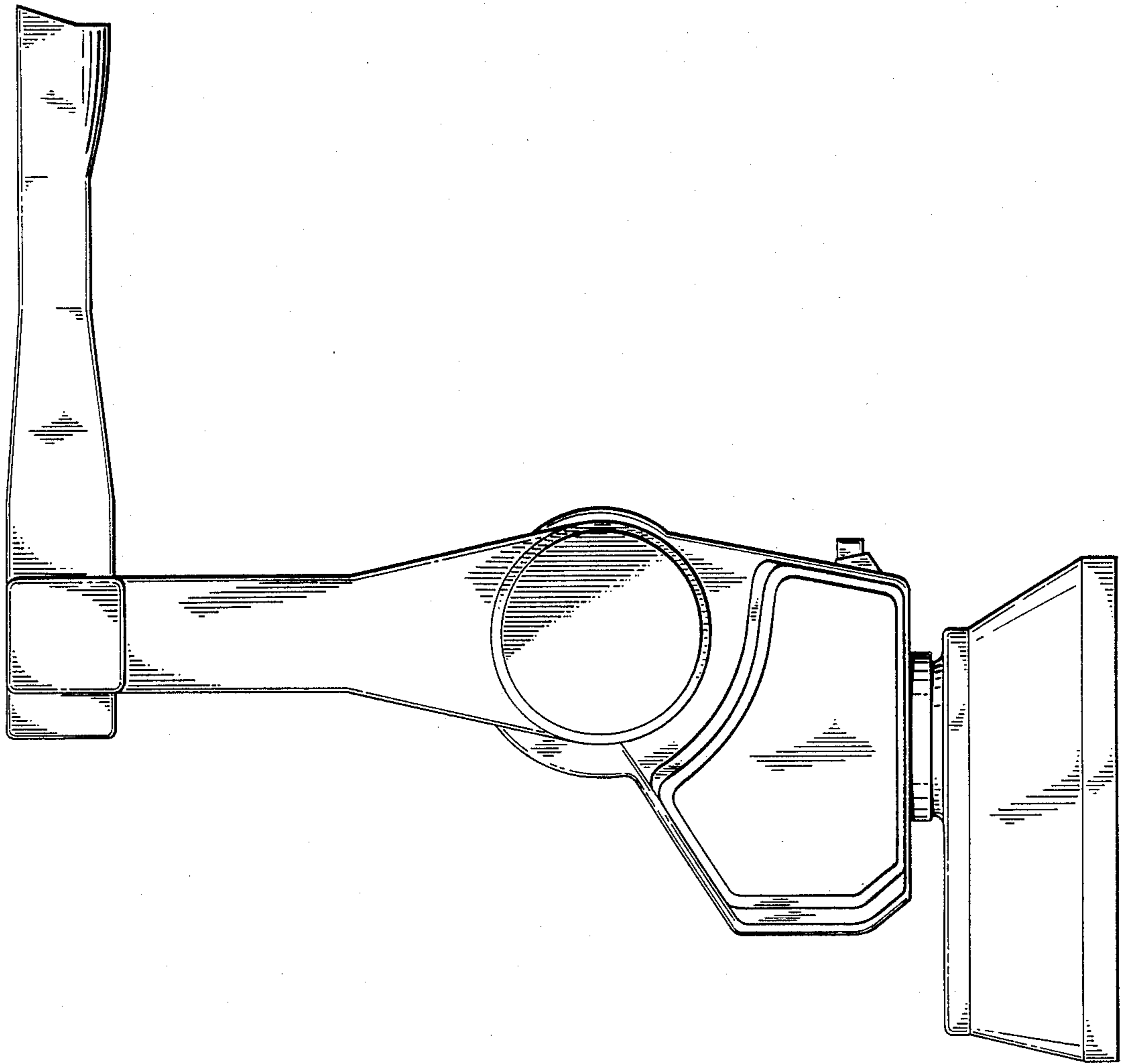
[52] U.S. Cl. .... D15/199

[58] Field of Search ..... D15/199, 122; 901/23, 901/1; 414/735

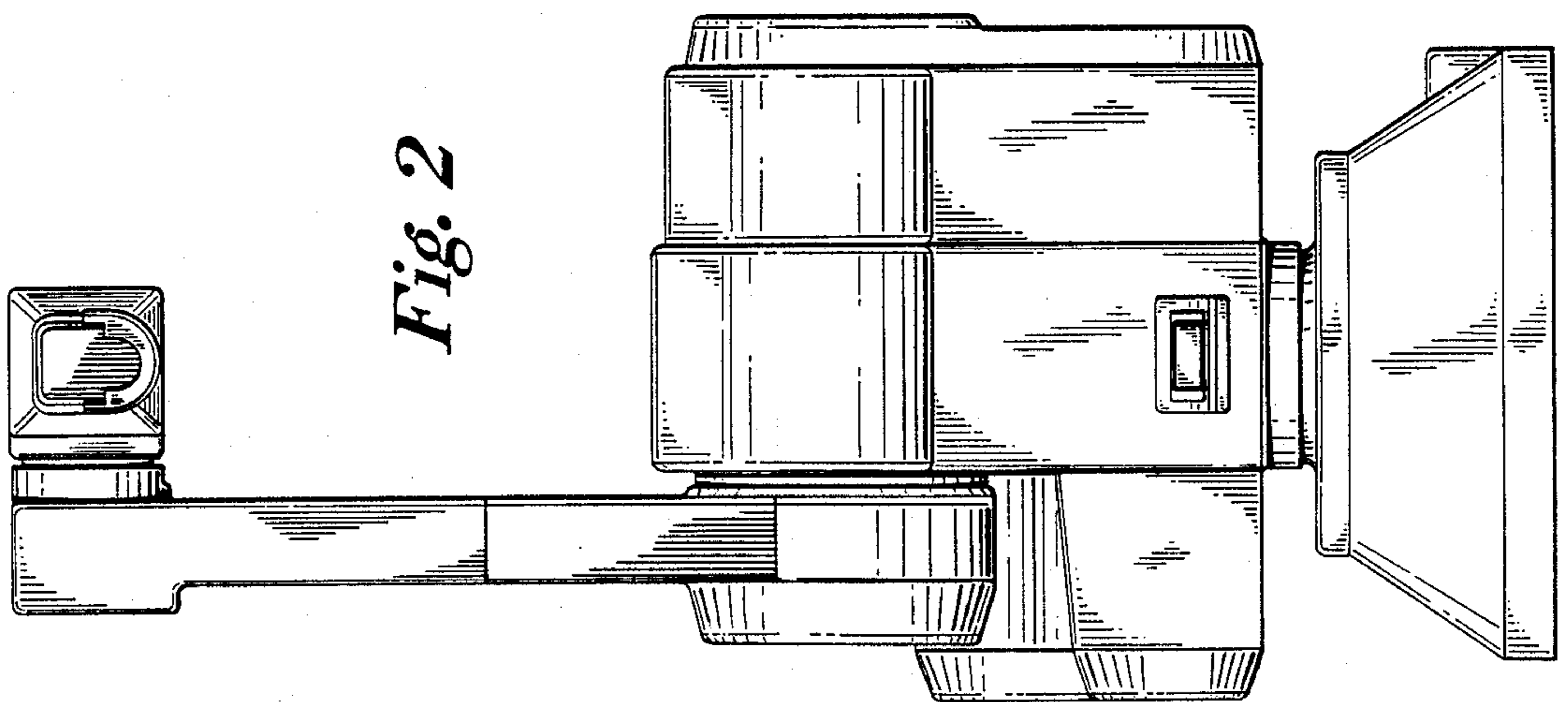




*Fig. 1*



*Fig. 2*



*Fig. 3*

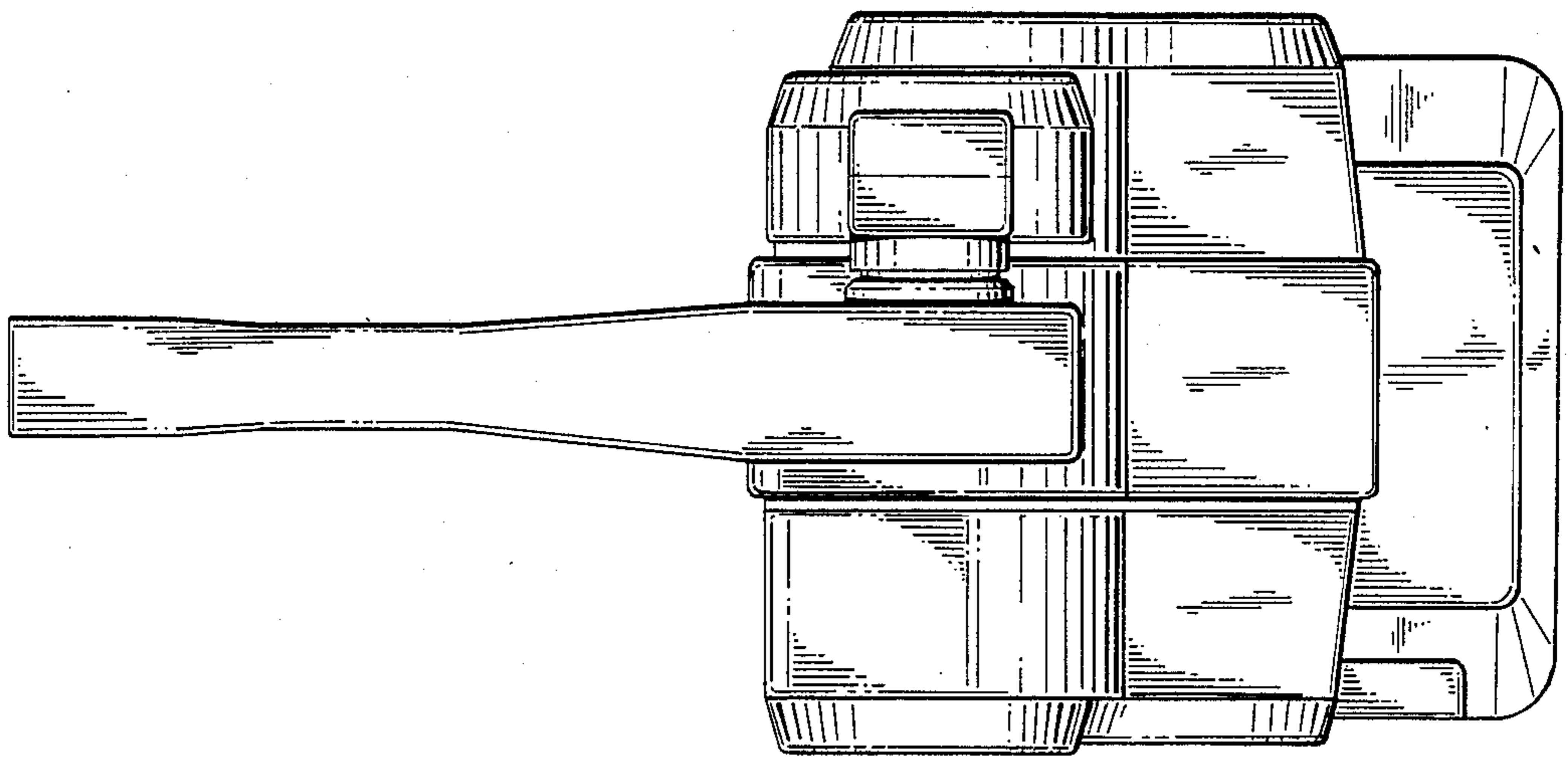


Fig. 5

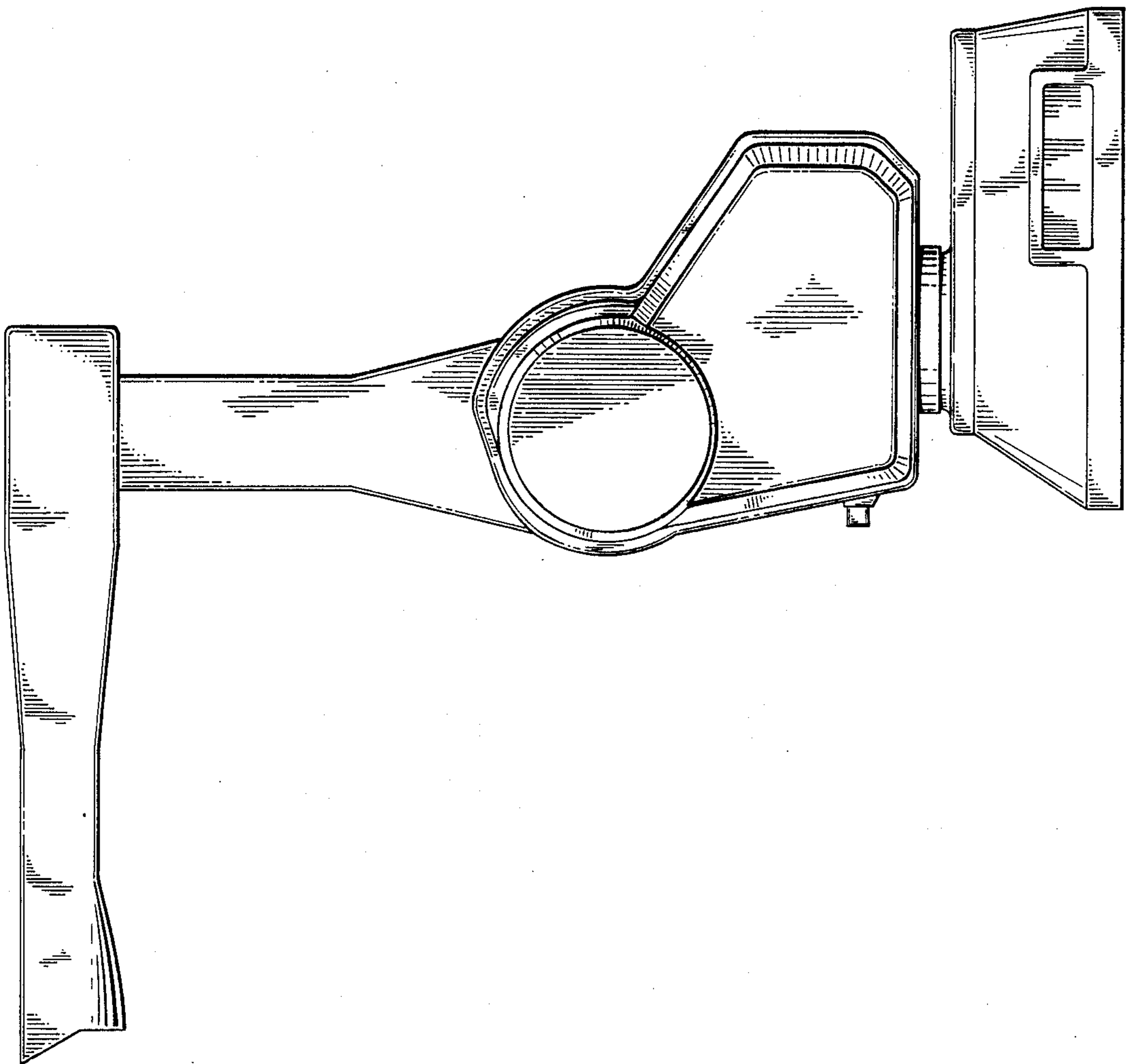
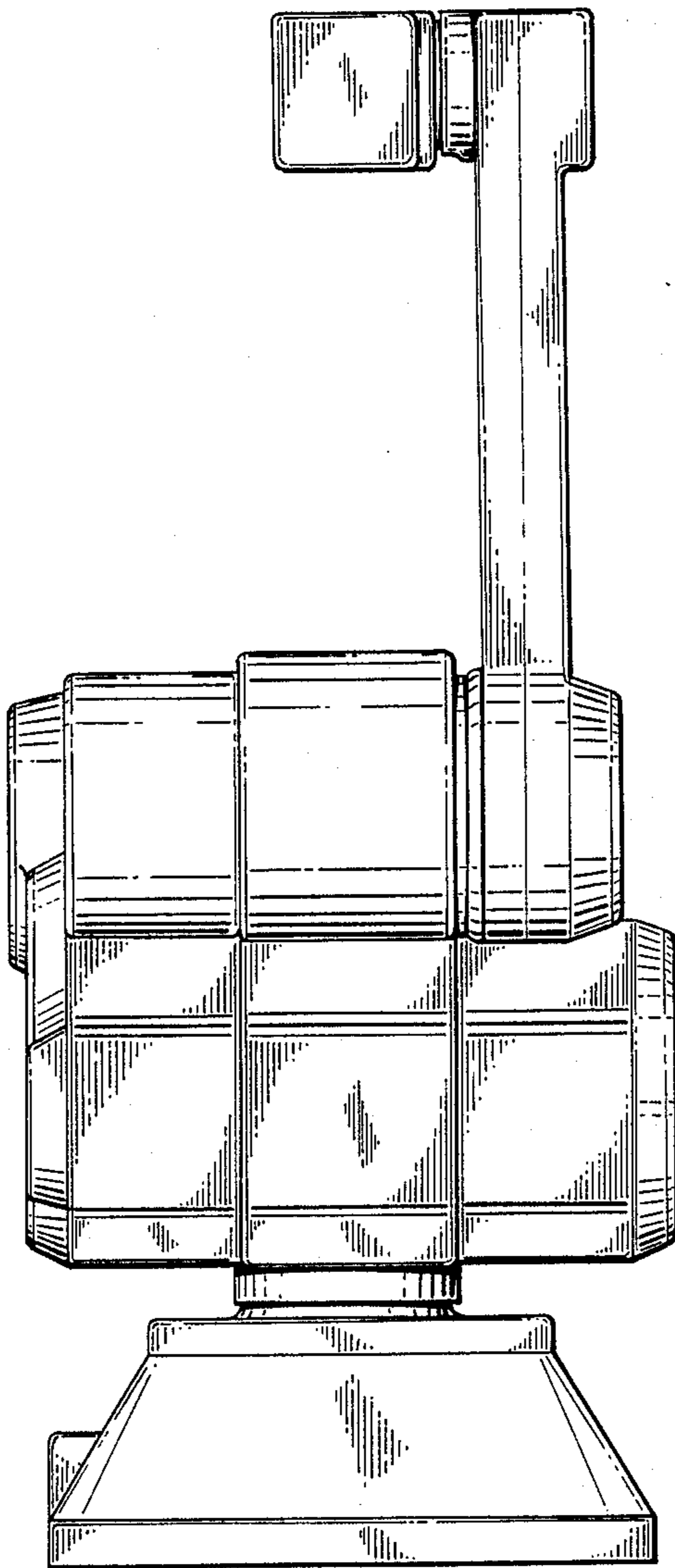


Fig. 4



*Fig. 6*