

[54] PORTABLE INTERNAL COMBUSTION POWER TOOL

[75] Inventors: Katsumi Kiyooka, Warabi; Hideko Inomata, Higashiyamato, both of Japan

[73] Assignee: Komatsu Zenoah Company, Tokyo, Japan

[\*\*] Term: 14 Years

[21] Appl. No.: 27,668

[22] Filed: Mar. 18, 1987

[52] U.S. Cl. .... D15/10

[58] Field of Search ..... D15/10-12, D15/14, 16-17, 28-29; D32/15-16; 56/233, 235, 249, 255, 294-295, 320.1-320.2, DIG. 17, DIG. 20; 123/195 R; 417/234; 30/388-390, 276, 286

[56] References Cited

U.S. PATENT DOCUMENTS

D. 260,394	8/1981	Tuggle .....	D15/1
D. 274,620	7/1984	Murakami et al. ....	D15/1
D. 279,319	6/1985	McCloskey et al. ....	D32/15
D. 290,365	6/1987	Hatano et al. ....	D15/10
D. 292,980	12/1987	Tomita et al. ....	D15/16
D. 297,274	8/1988	Komiya et al. ....	D32/15
D. 299,571	1/1989	Kiyooka et al. ....	D32/15

Primary Examiner—A. Hugo Word  
Assistant Examiner—Ruth McInroy  
Attorney, Agent, or Firm—Foley & Lardner, Schwartz, Jeffery, Schwaab, Mack, Blumenthal & Evans

[57] CLAIM

The ornamental design for a portable internal combustion power tool, as shown and described.

DESCRIPTION

FIG. 1 is a left side elevational view of a portable internal combustion power tool showing our new design; FIG. 2 is a right side elevational view thereof; FIG. 3 is a front elevational view thereof; FIG. 4 is a rear elevational view thereof; FIG. 5 is a top plan view thereof; FIG. 6 is a bottom plan view thereof; FIG. 7 is a left side elevational view of a second embodiment thereof; FIG. 8 is a right side elevational view thereof; FIG. 9 is a front elevational view thereof; FIG. 10 is a rear elevational view thereof; FIG. 11 is a top plan view thereof; FIG. 12 is a bottom plan view thereof; FIG. 13 is a left side elevational view of the engine thereof; FIG. 14 is a right side elevational view thereof; FIG. 15 is a front elevational view thereof; FIG. 16 is a rear elevational view thereof; FIG. 17 is a top plan view thereof; FIG. 18 is a bottom plan view thereof; FIG. 19 is a left side elevational view of the engine and handle thereof; FIG. 20 is a right side elevational view thereof; FIG. 21 is a front elevational view thereof; FIG. 22 is a rear elevational view thereof; FIG. 23 is a top plan view thereof; and FIG. 24 is a bottom plan view thereof.

The engine unit in FIGS. 13-18 and the engine unit and handle in FIGS. 19-24 are shown separate for clarity of illustration only.

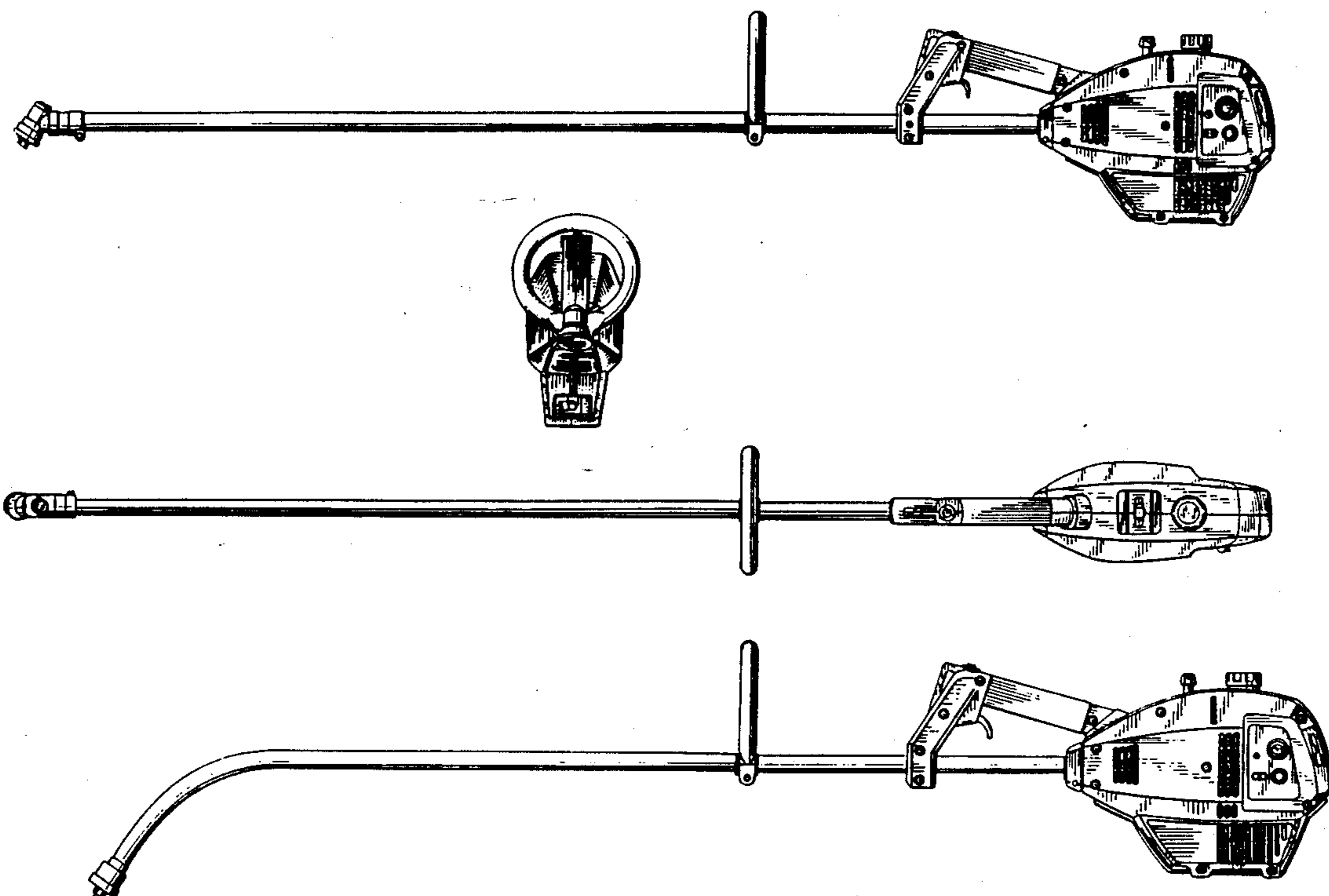

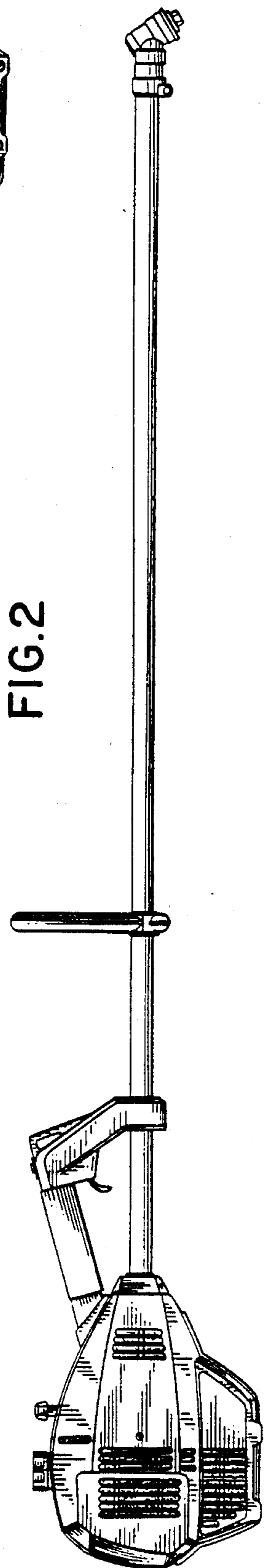
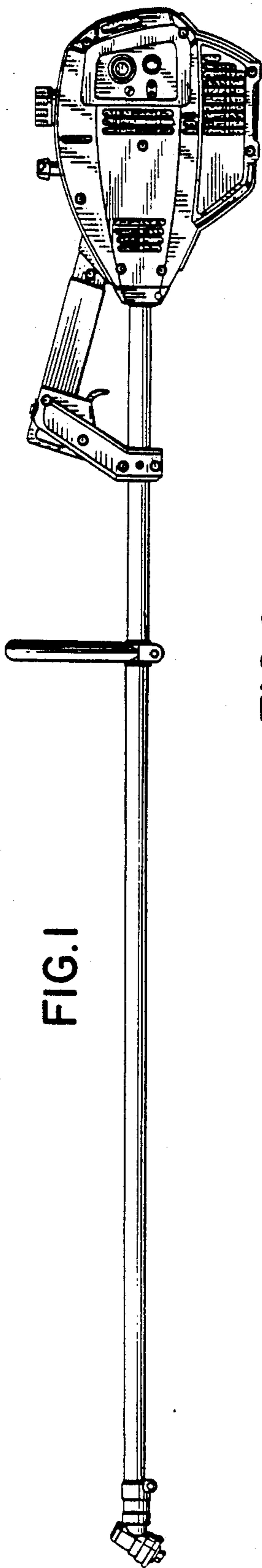

FIG. 4

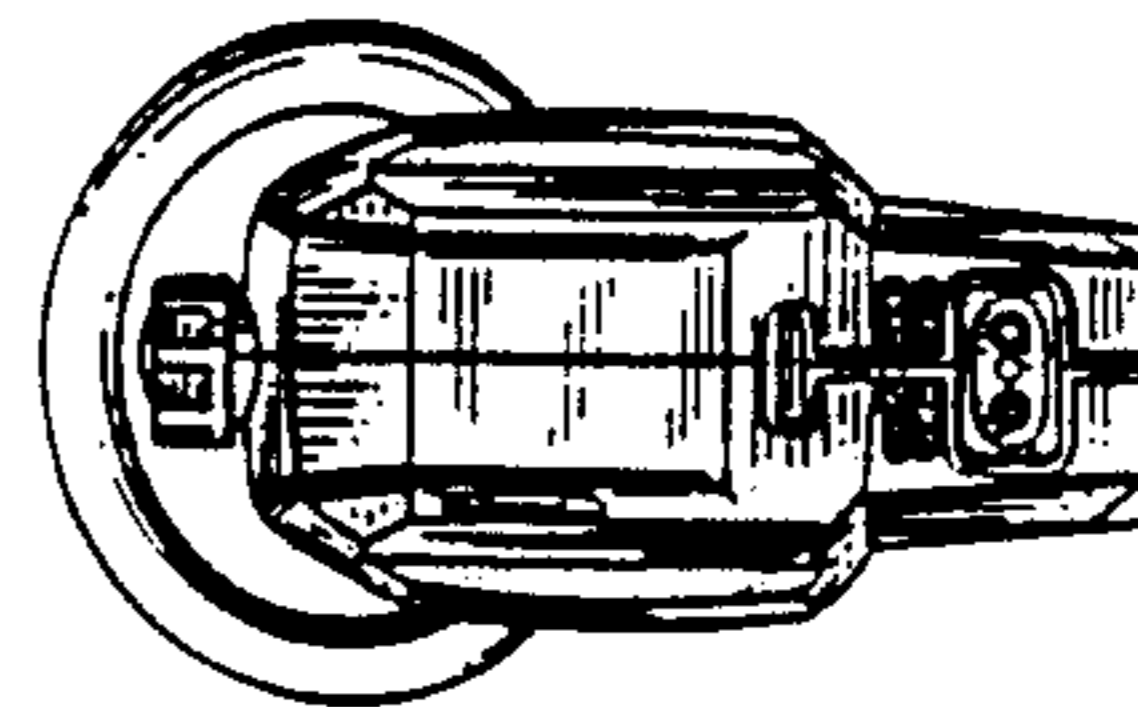
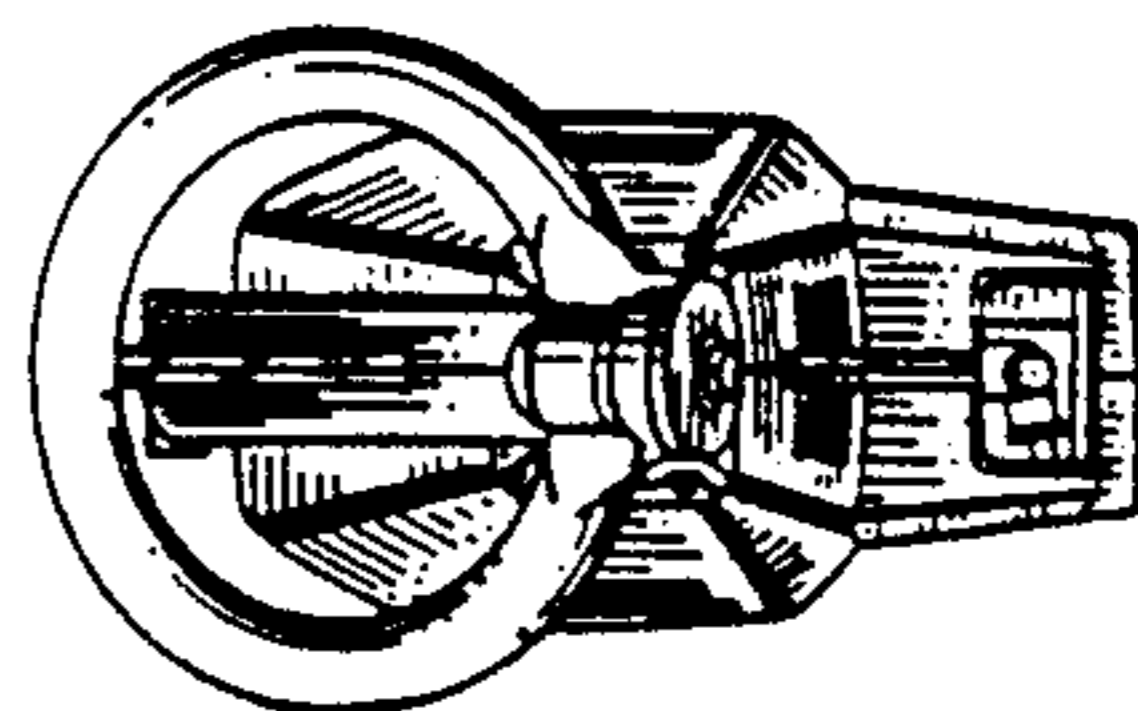

FIG. 3



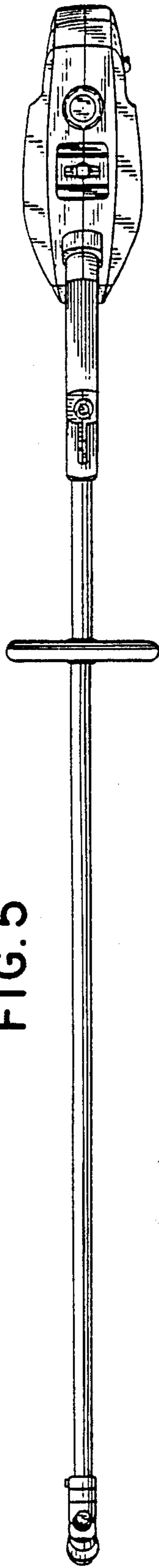

FIG. 5

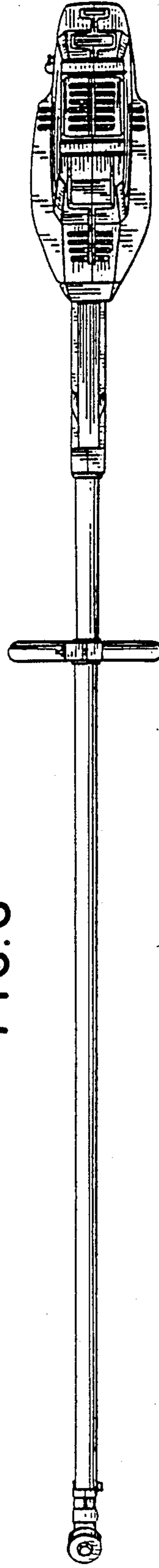

FIG. 6

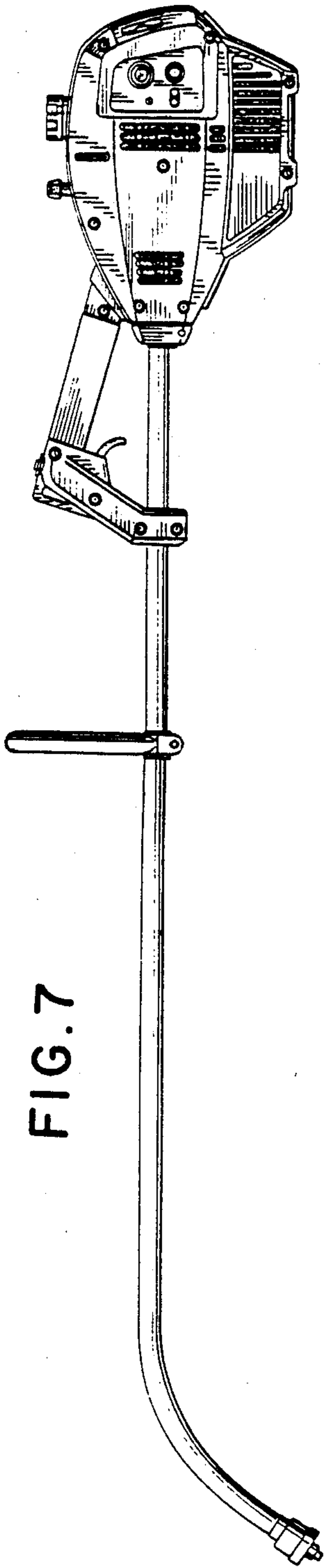

FIG. 8

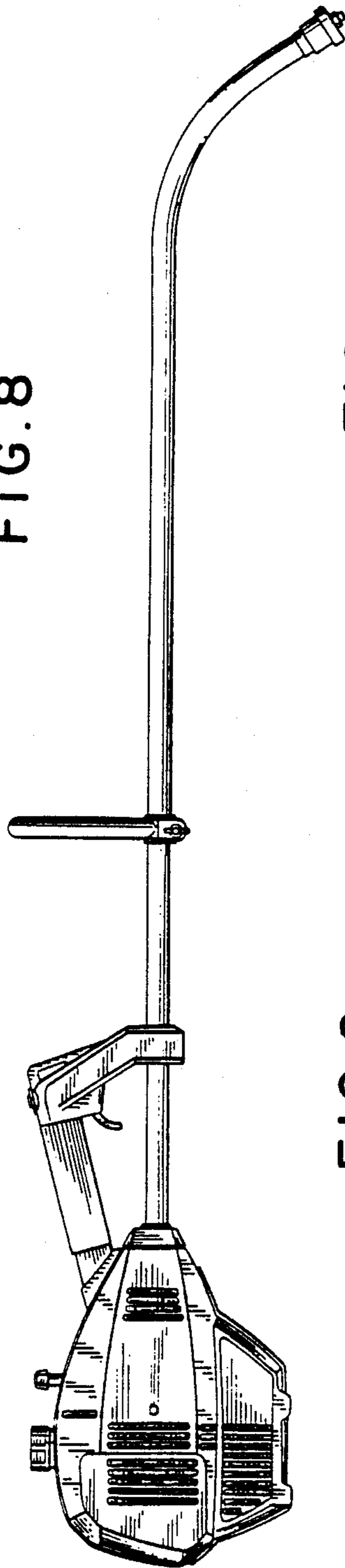

FIG. 10

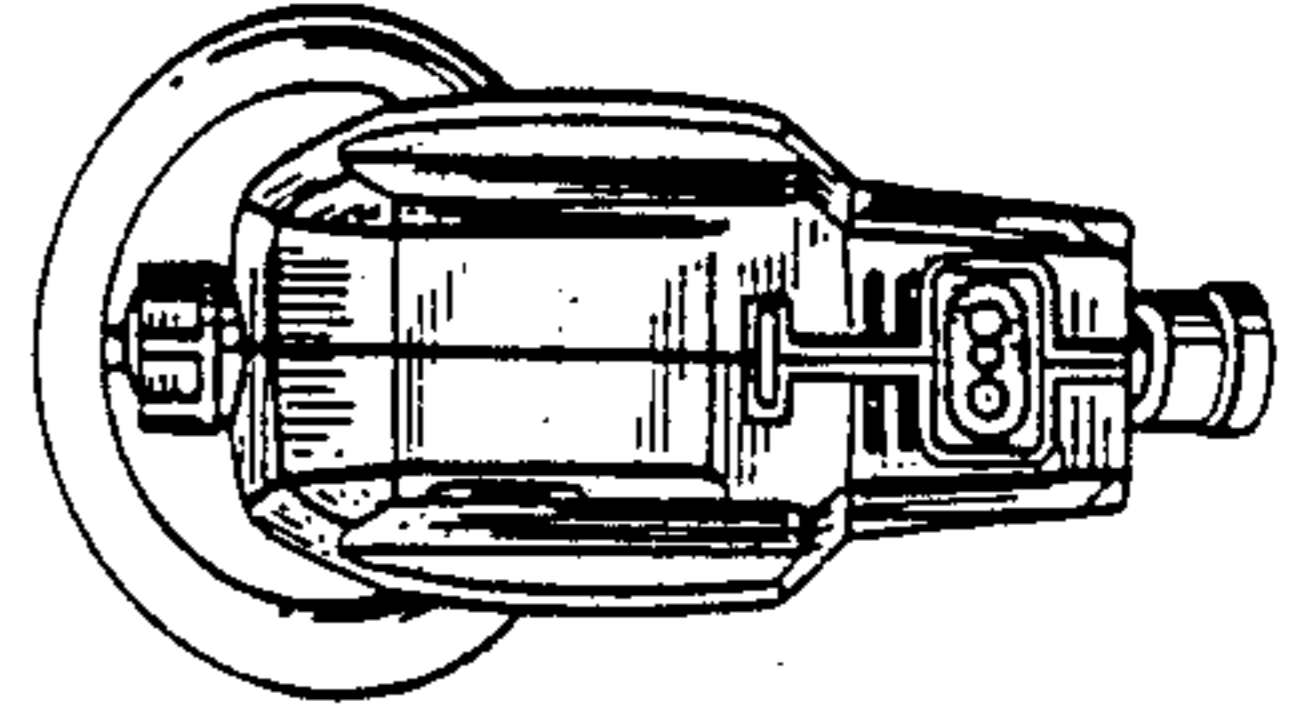
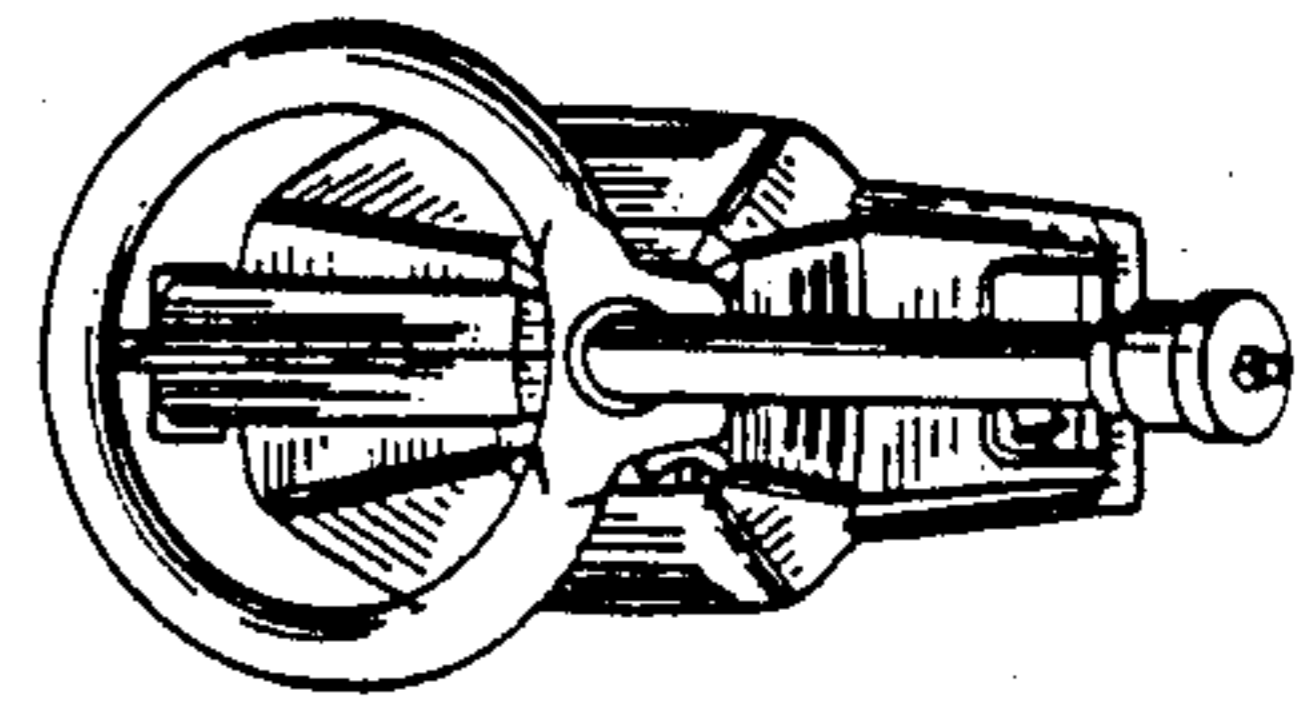

FIG. 9





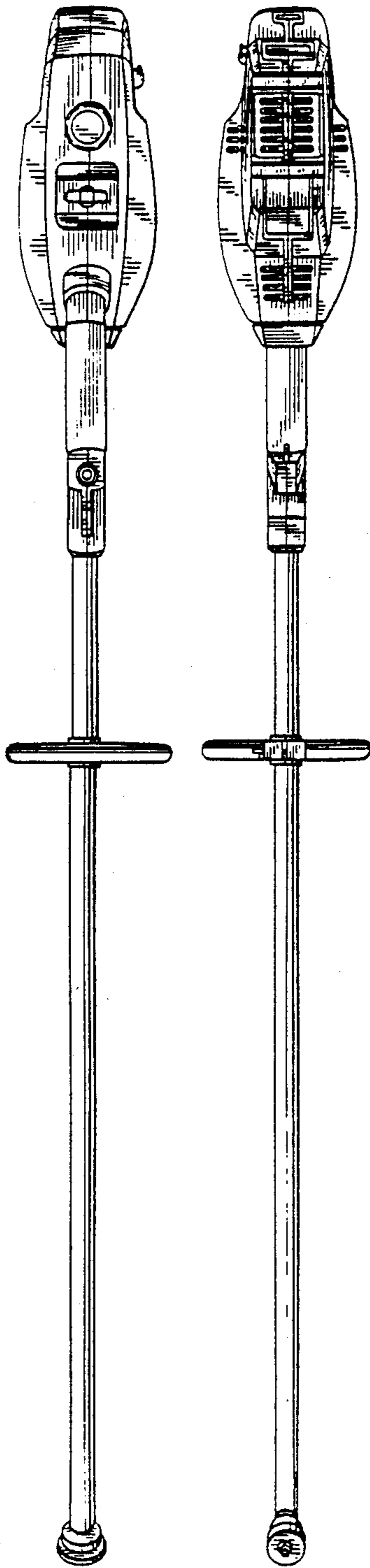

FIG. 11

FIG. 12

FIG. 13

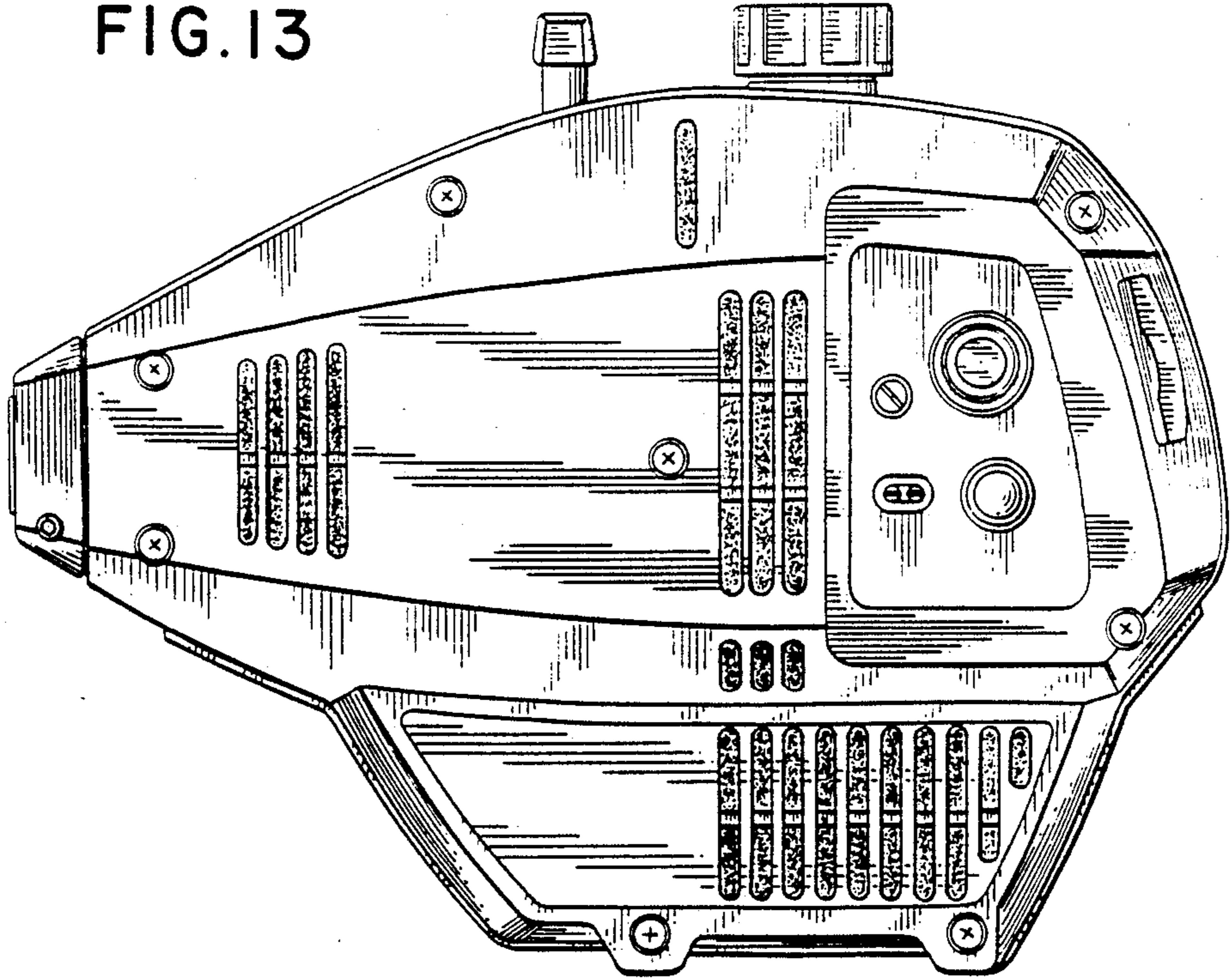

FIG. 14

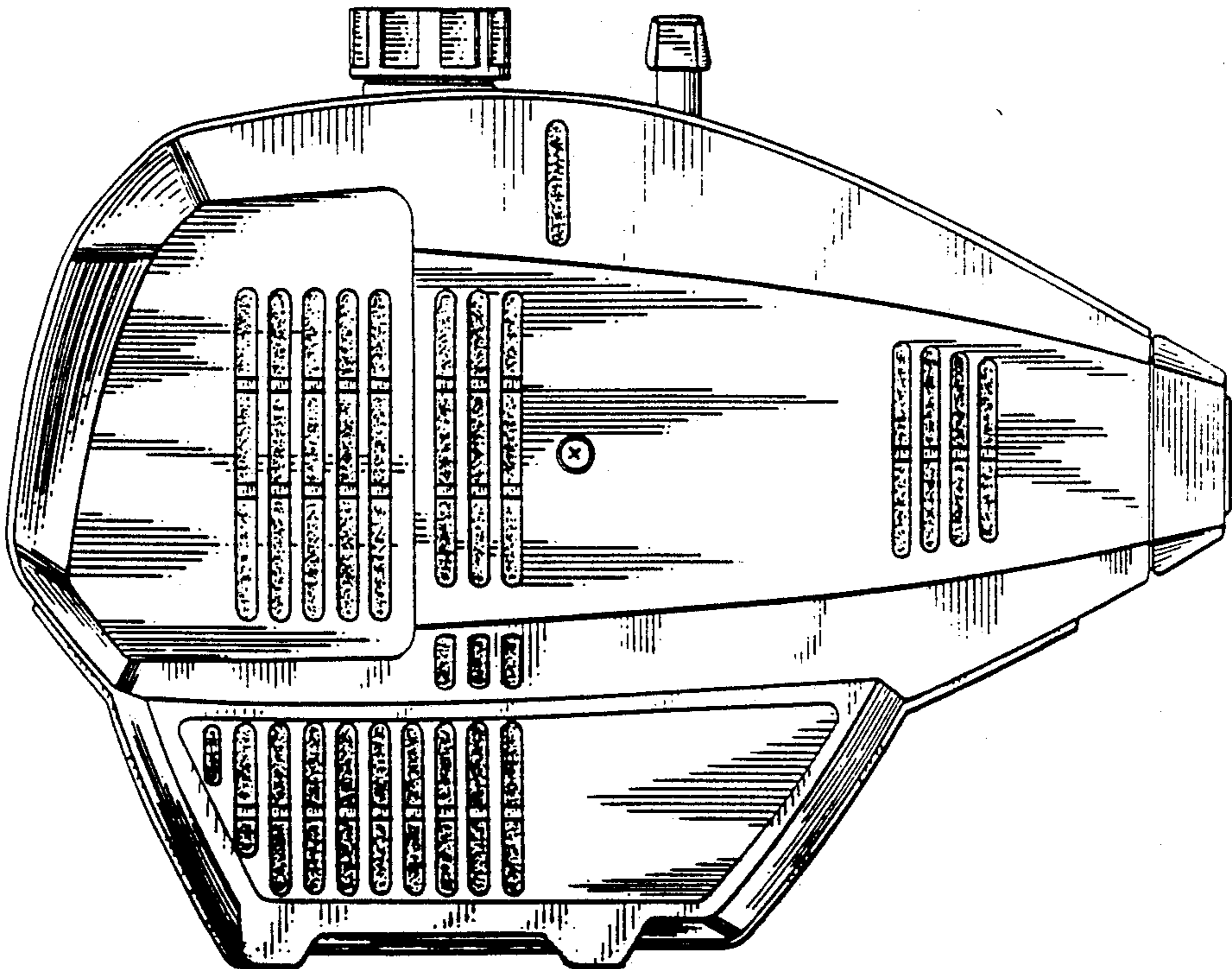

FIG. 15

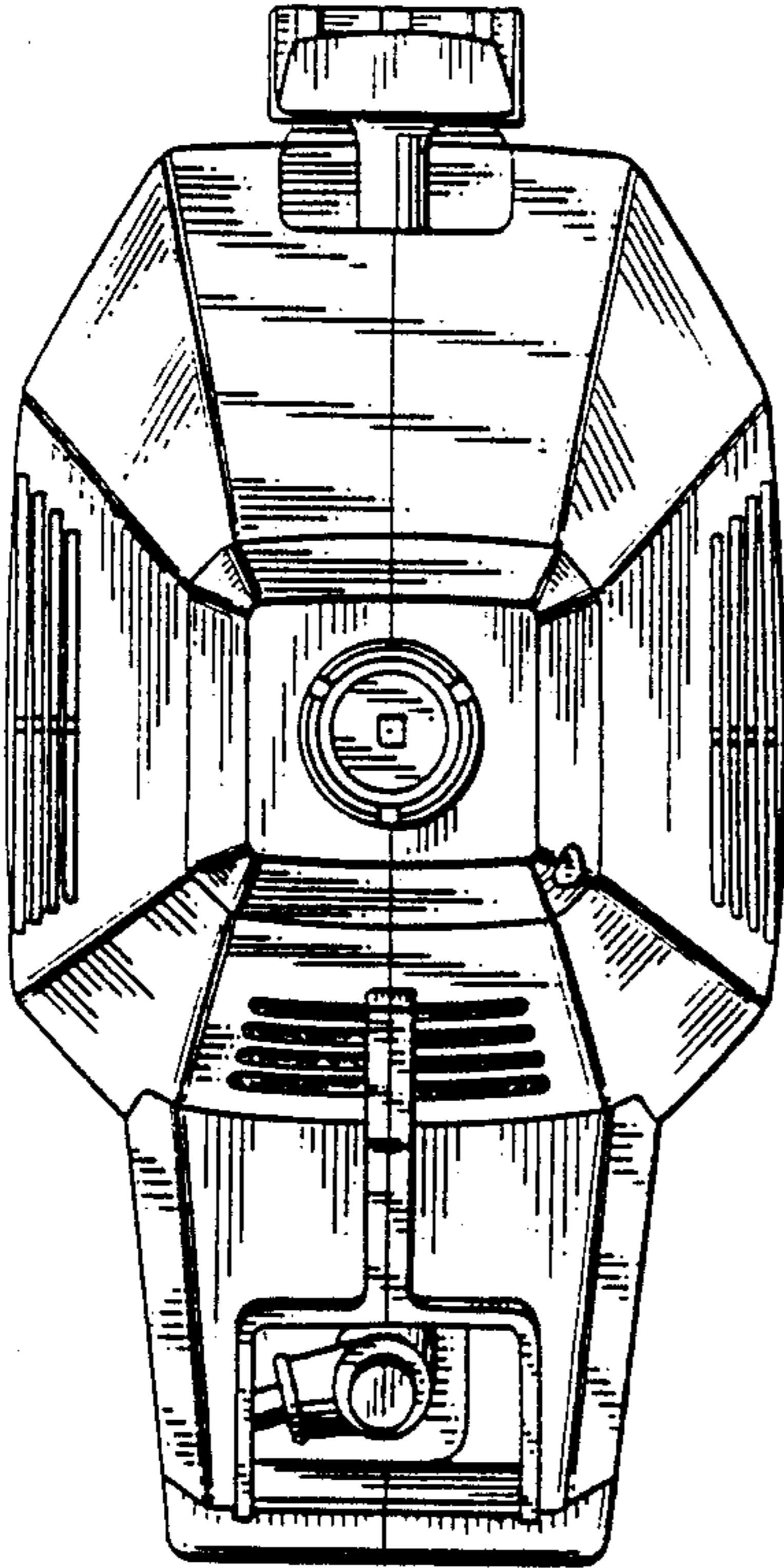

FIG. 16

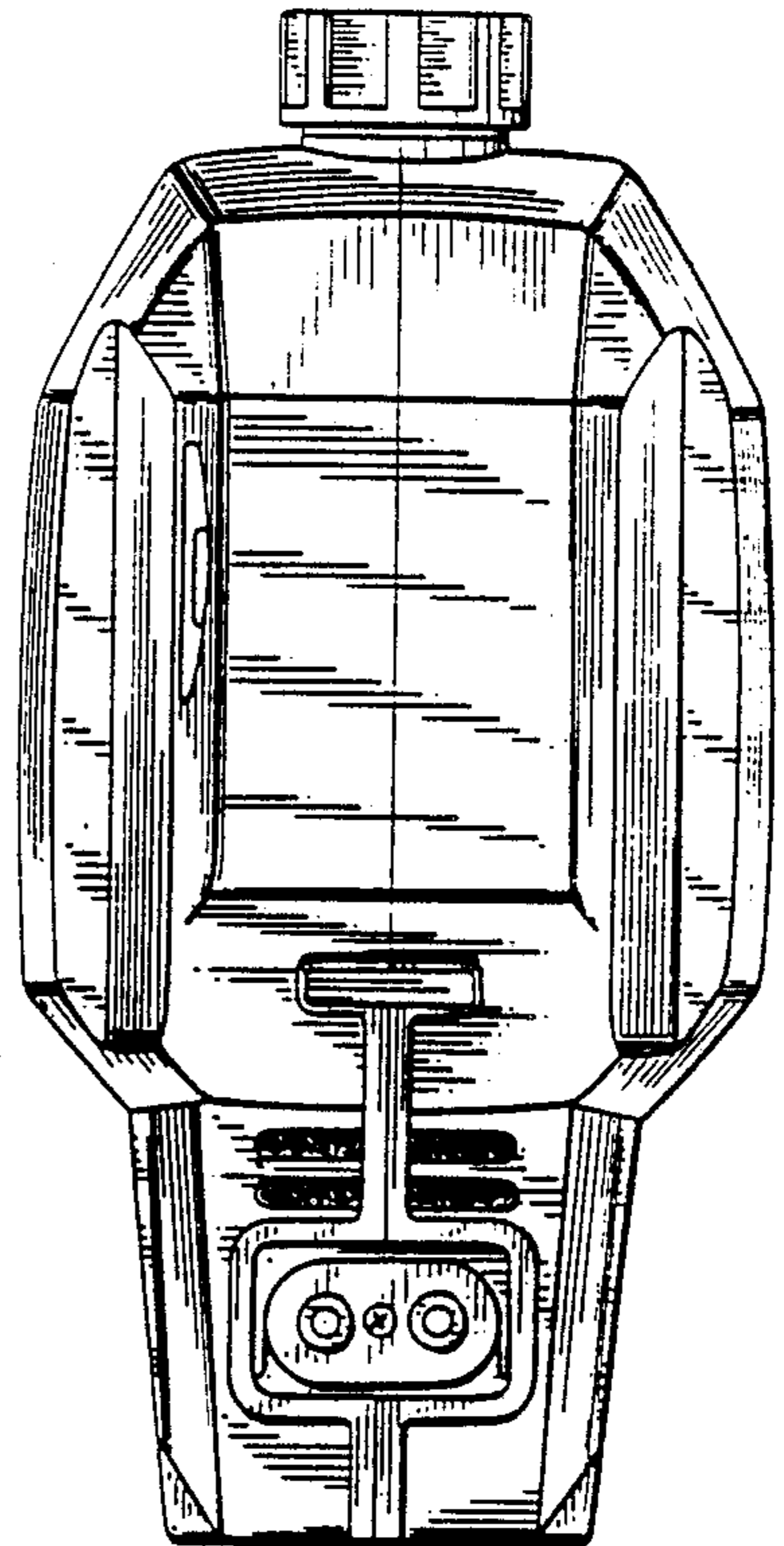

FIG. 17

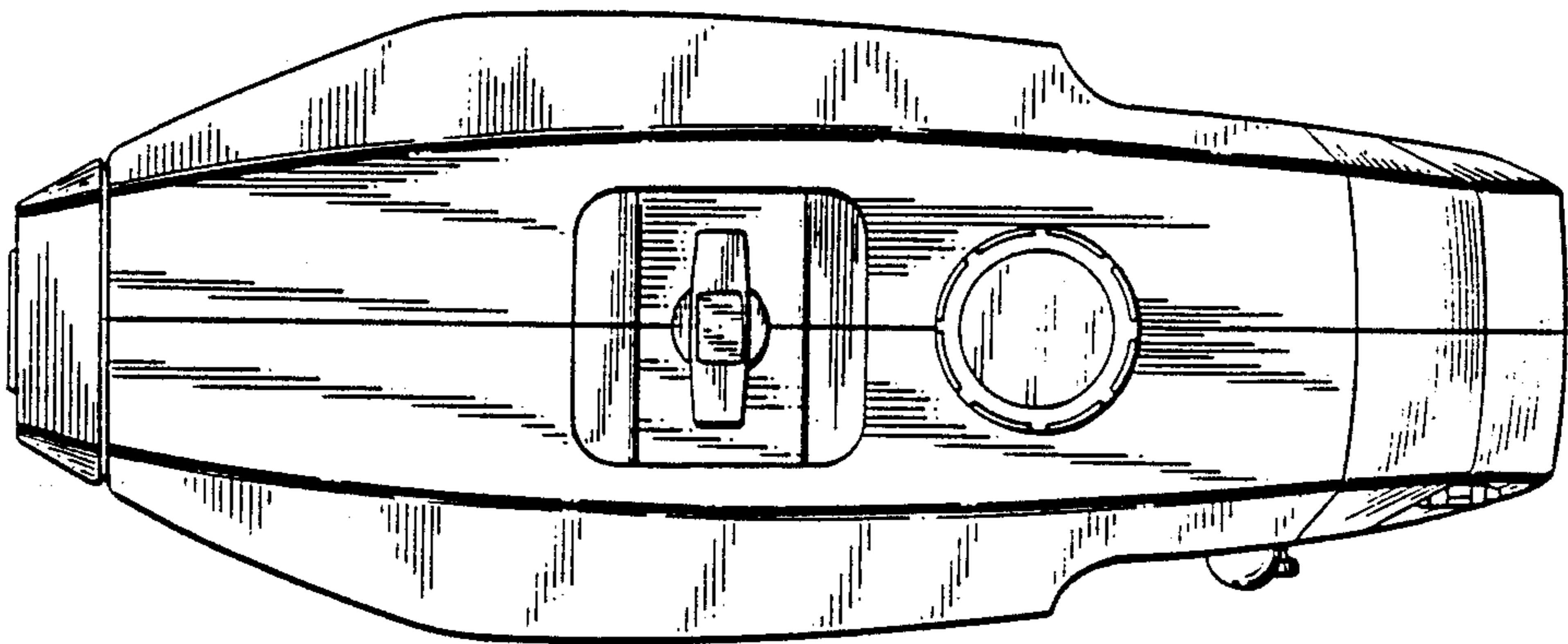

FIG. 18

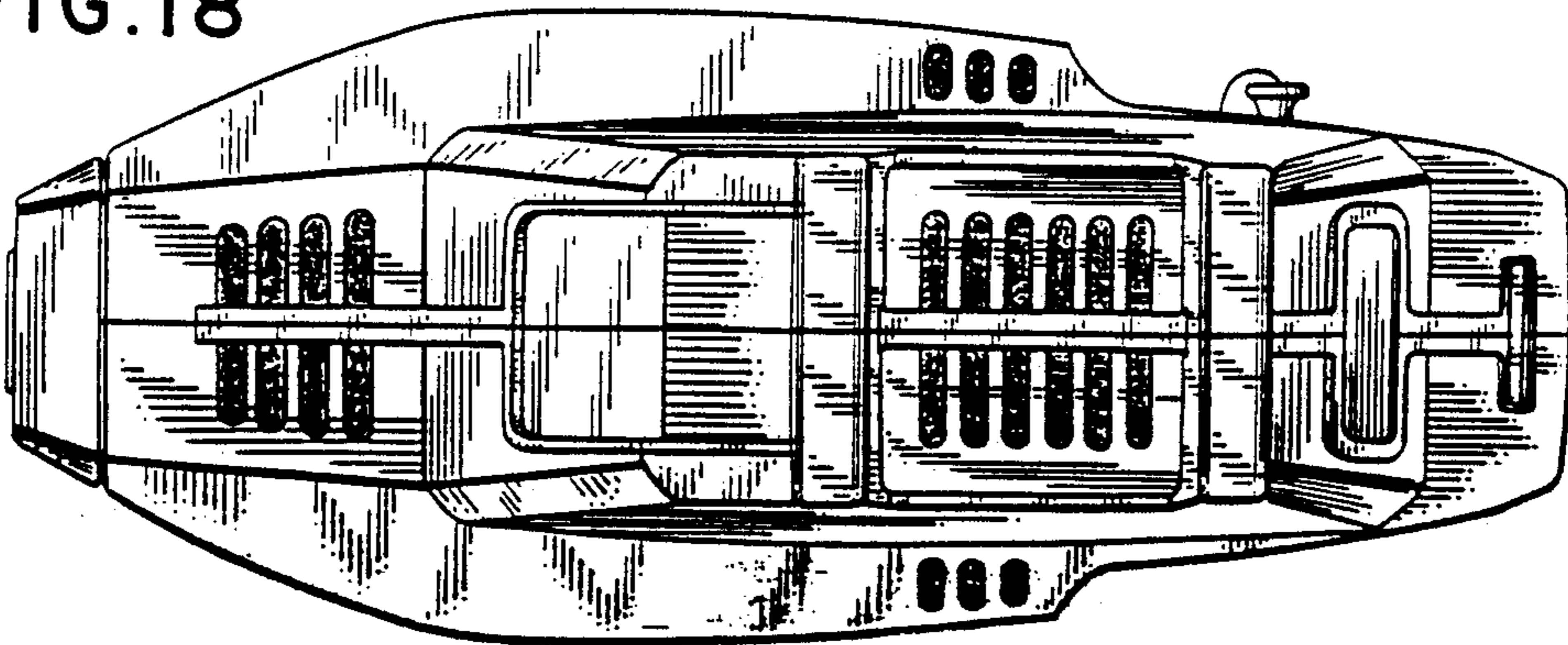



FIG. 19

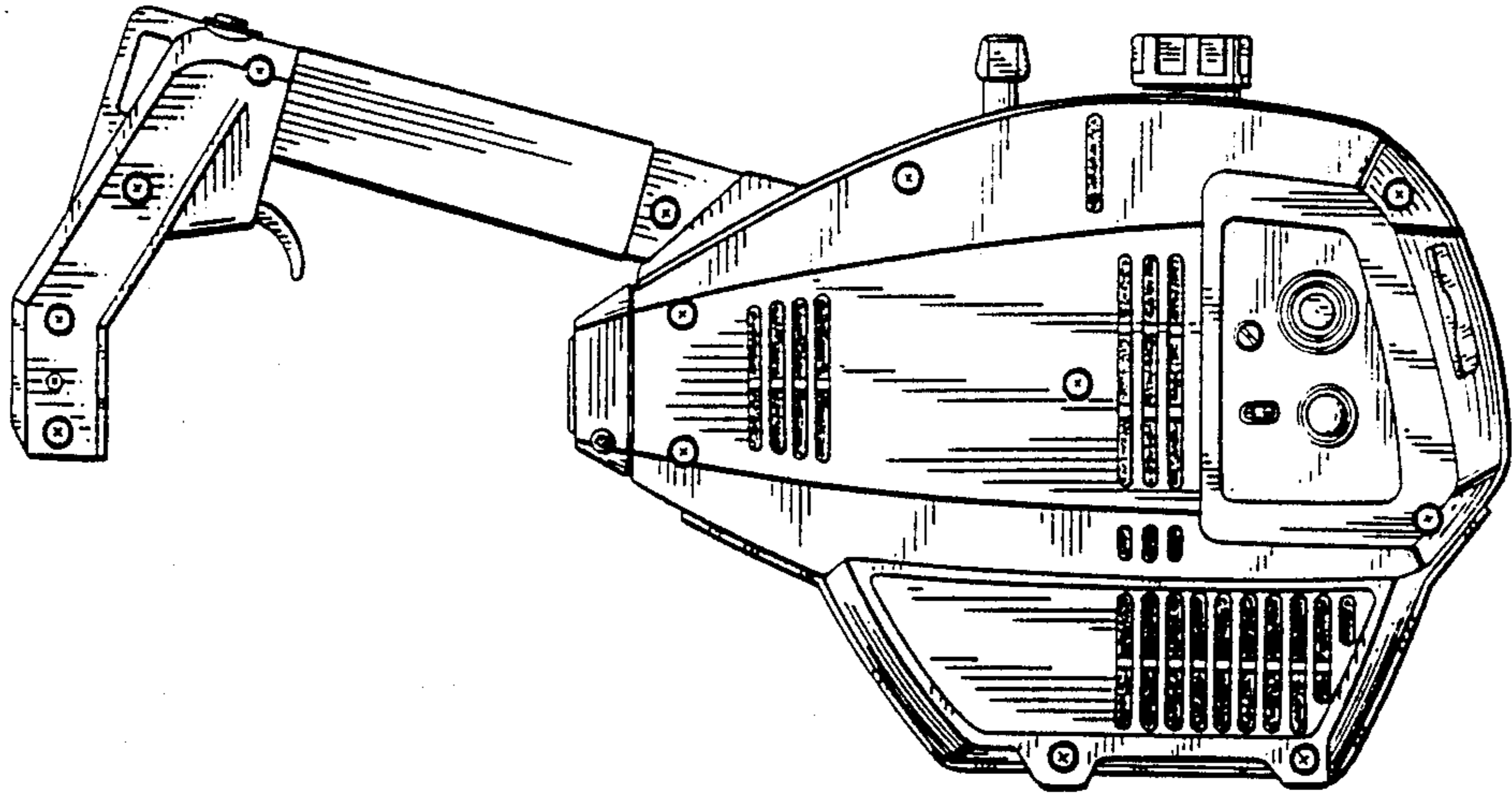

FIG. 20

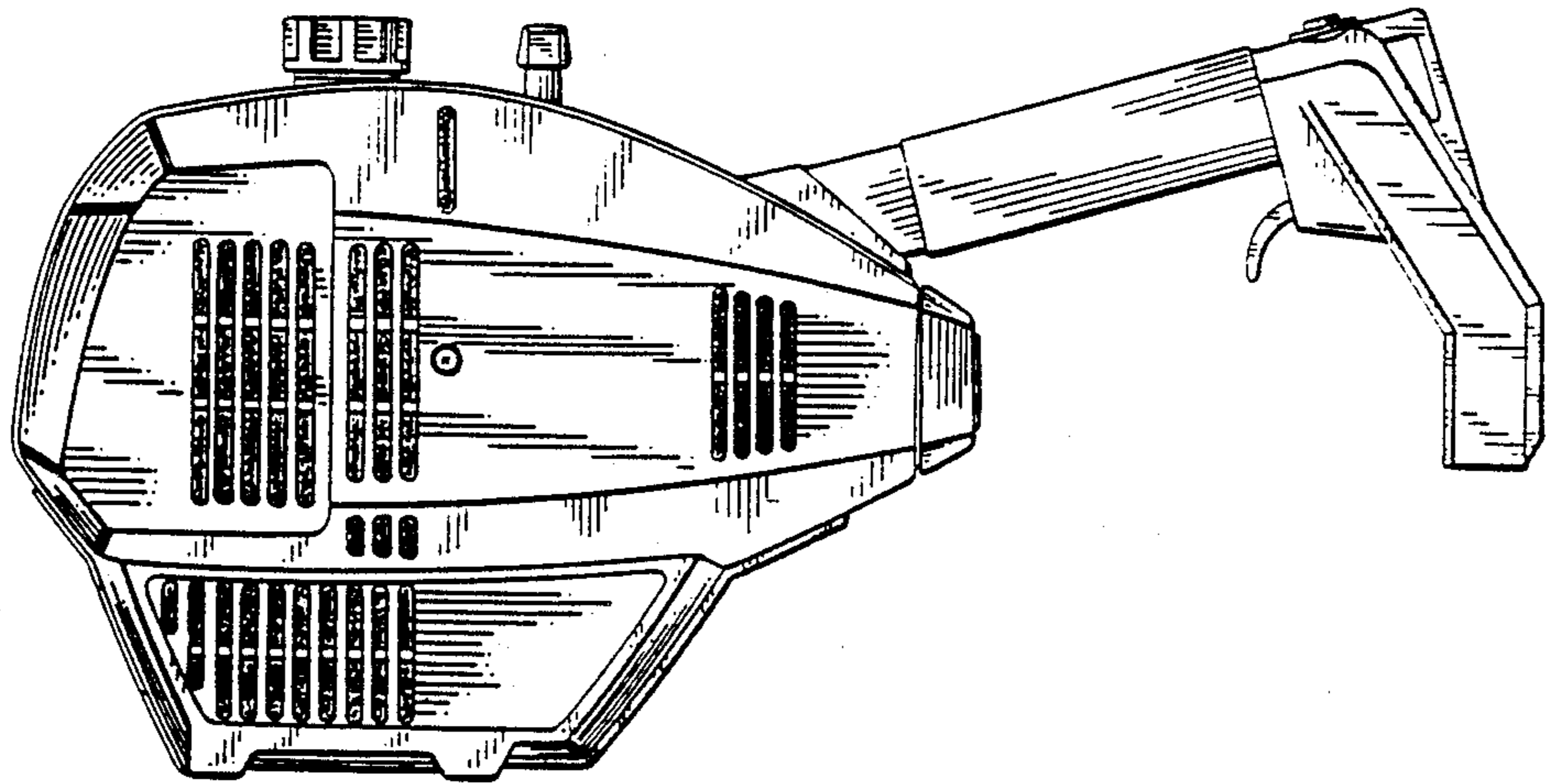



FIG. 21

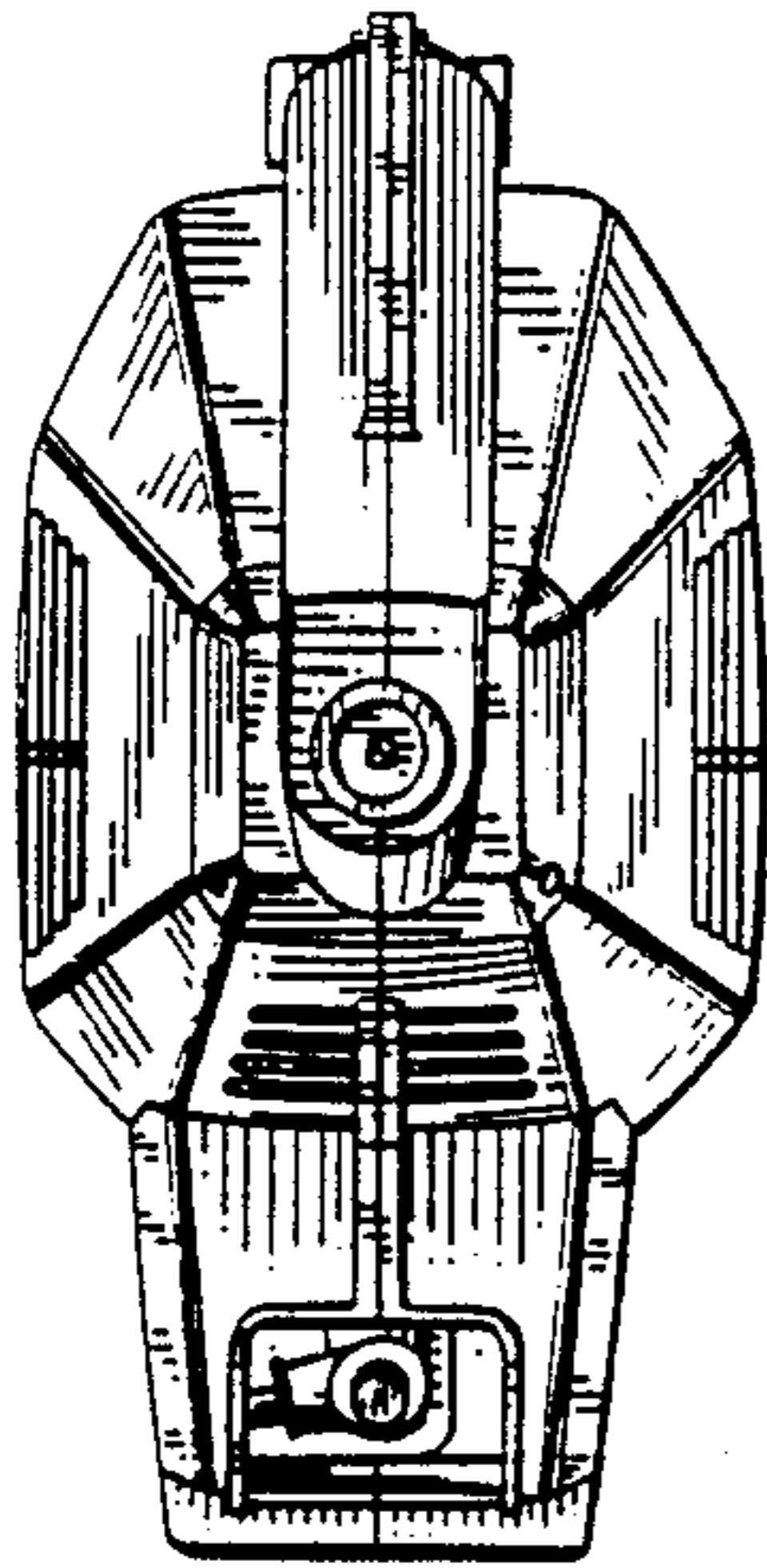

FIG. 22

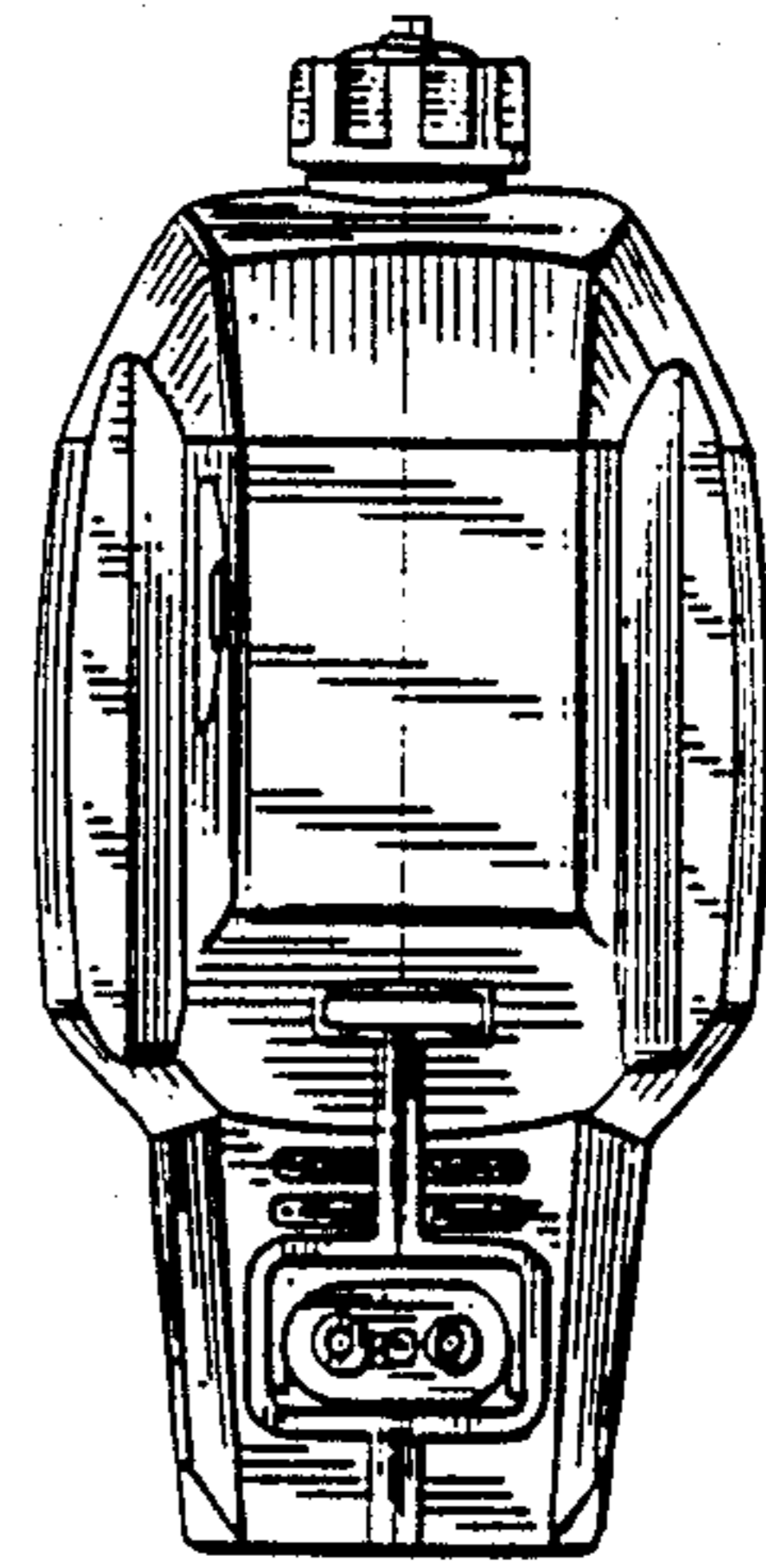

FIG. 23

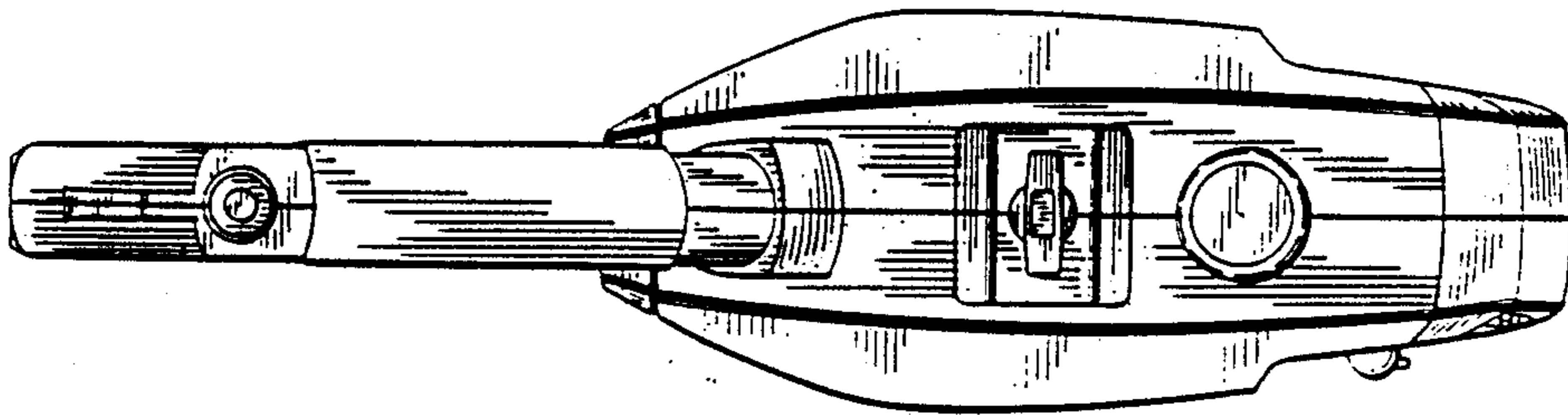

FIG. 24

