

[54] ENGINE

[75] Inventors: Gordon D. Kelly, Elm Grove, Wis.;
Ronald J. Hoffman, Phoenix, Ariz.

[73] Assignee: Kohler Co., Kohler, Wis.

[**] Term: 14 Years

[21] Appl. No.: 222,683

[22] Filed: Jul. 21, 1988

[52] U.S. Cl. D15/1

[58] Field of Search D15/1, 3; D13/1, 2;
123/22, 50 R, 50 A, 50 B, 51 R, 51 A, 51 B, 52
R, 56 R, 56 A, 56 B, 65 R, 311

[56] References Cited

U.S. PATENT DOCUMENTS

D. 247,177	2/1978	Stevens	D15/1
D. 257,844	1/1981	Stevens	D15/1
D. 276,515	11/1984	Yaguchi	D13/1
D. 281,492	11/1985	Yaguchi	D13/2
D. 282,071	1/1986	Nakamura	D15/1
D. 284,862	7/1986	Iida	D15/1

OTHER PUBLICATIONS

Page 1 of a 1985 Kohler Co. brochure showing three "Magnum" engines. page 14 of a 1987 Kohler Co. brochure (admitted prior art) showing another "Magnum"

engine. Page 3 of a 1982 Kohler Co. brochure showing five K and KT series engines.

Page 1 of a 1987 Kohler Co. brochure showing the "Command" 12.5HP engine.

A page showing the Suzuki V120 and V160 engines. Three pages showing Honda's G, GX, and GXV engines.

Two pages of Briggs advertisements showing 8 HP and 12.5 HP "Vanguard" engines.

Primary Examiner—Wallace R. Burke

Assistant Examiner—Brian N. Vinson

Attorney, Agent, or Firm—Quarles & Brady

[57] CLAIM

The ornamental design for an engine, as shown and described.

DESCRIPTION

FIG. 1 is a perspective view taken from the top, front and right side of an engine showing our new design; FIG. 2 is a front elevational view thereof; FIG. 3 is a right side elevational view thereof; FIG. 4 is a left side elevational view thereof; FIG. 5 is a top plan view thereof; and FIG. 6 is a rear elevational view thereof.

The fragmentary broken-line representation of pull handles in FIGS. 1-5, and of auxiliary power take-offs in FIGS. 3-5, are for purposes of illustration only and form no part of the claimed design.

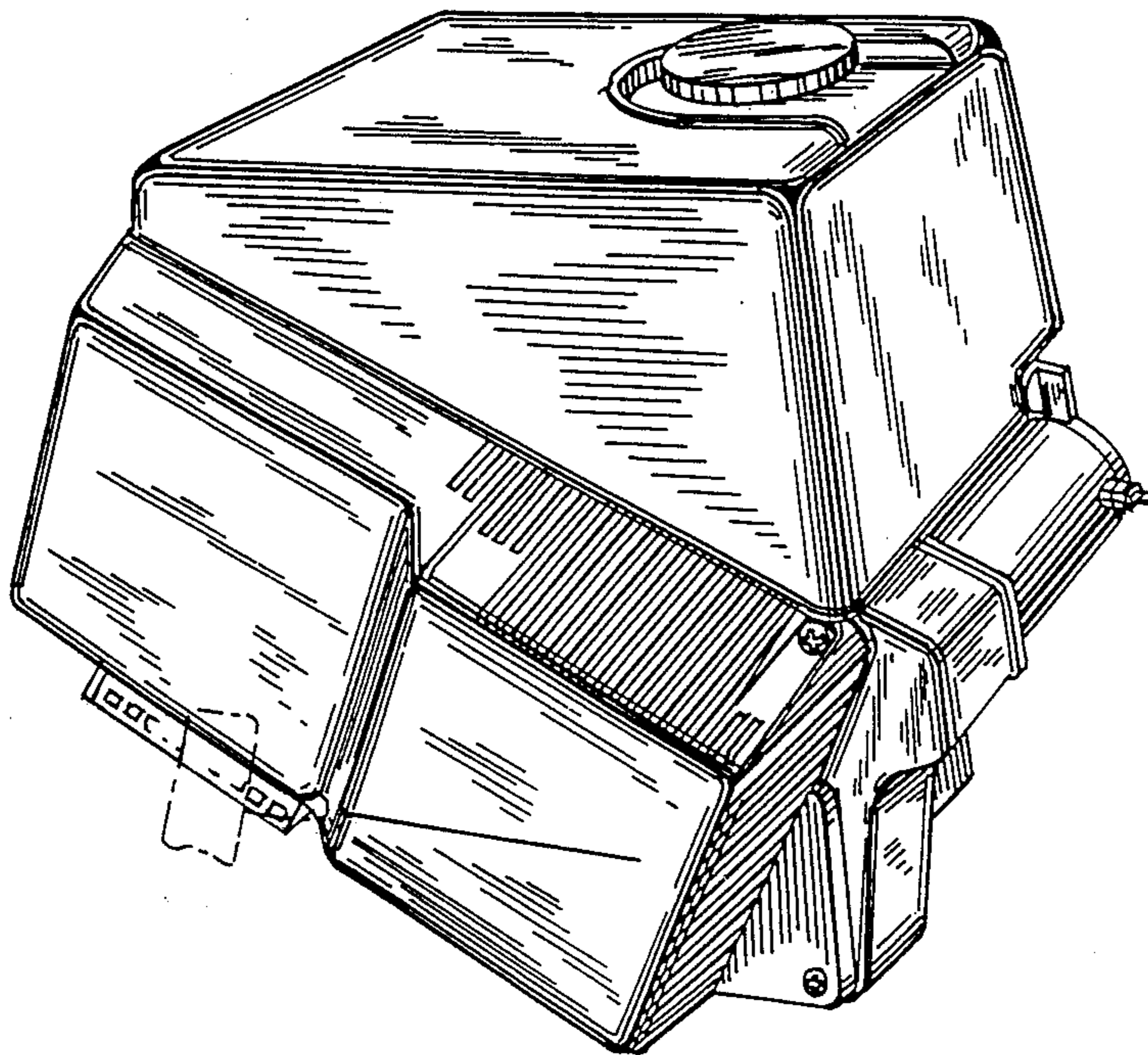

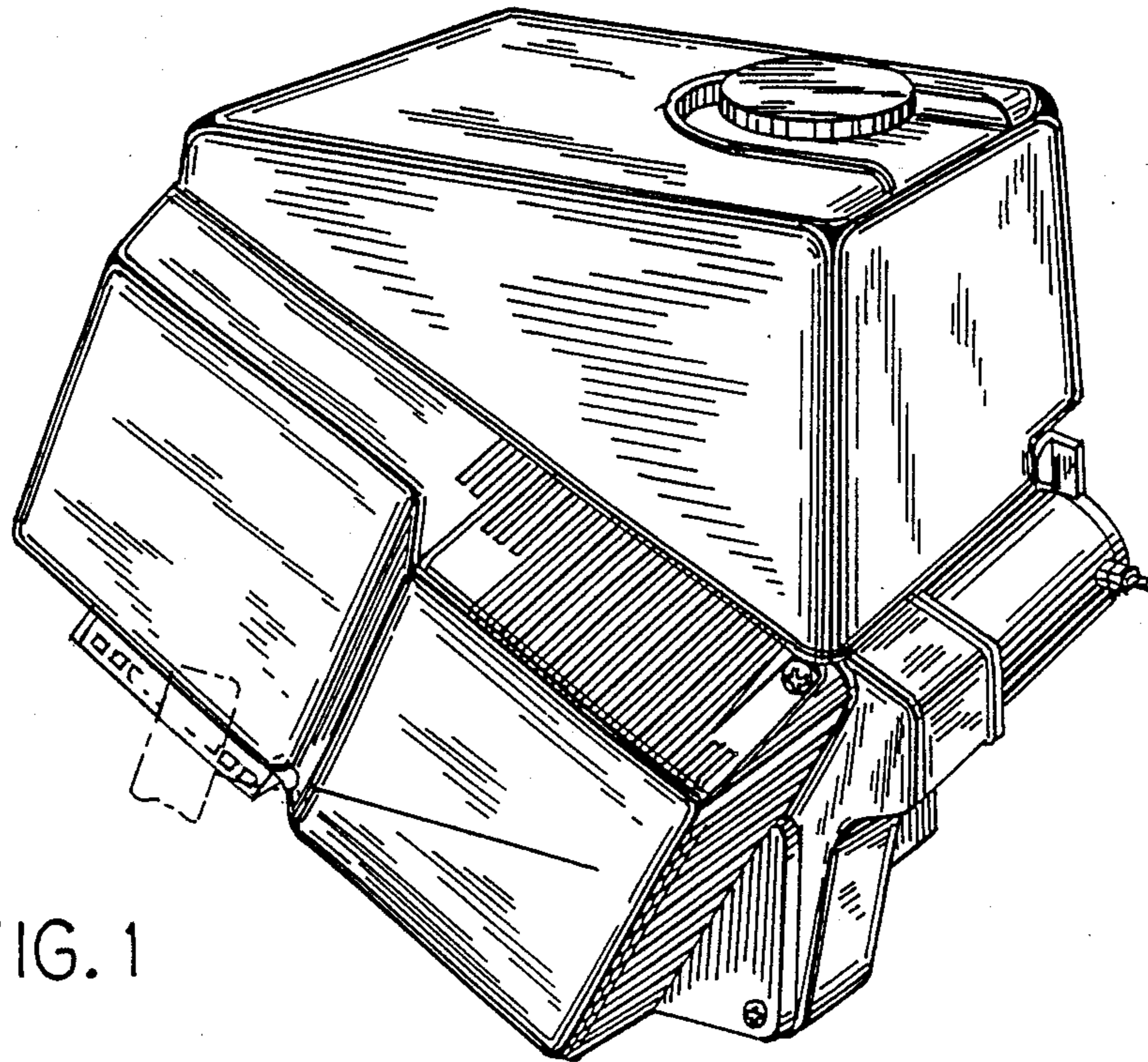
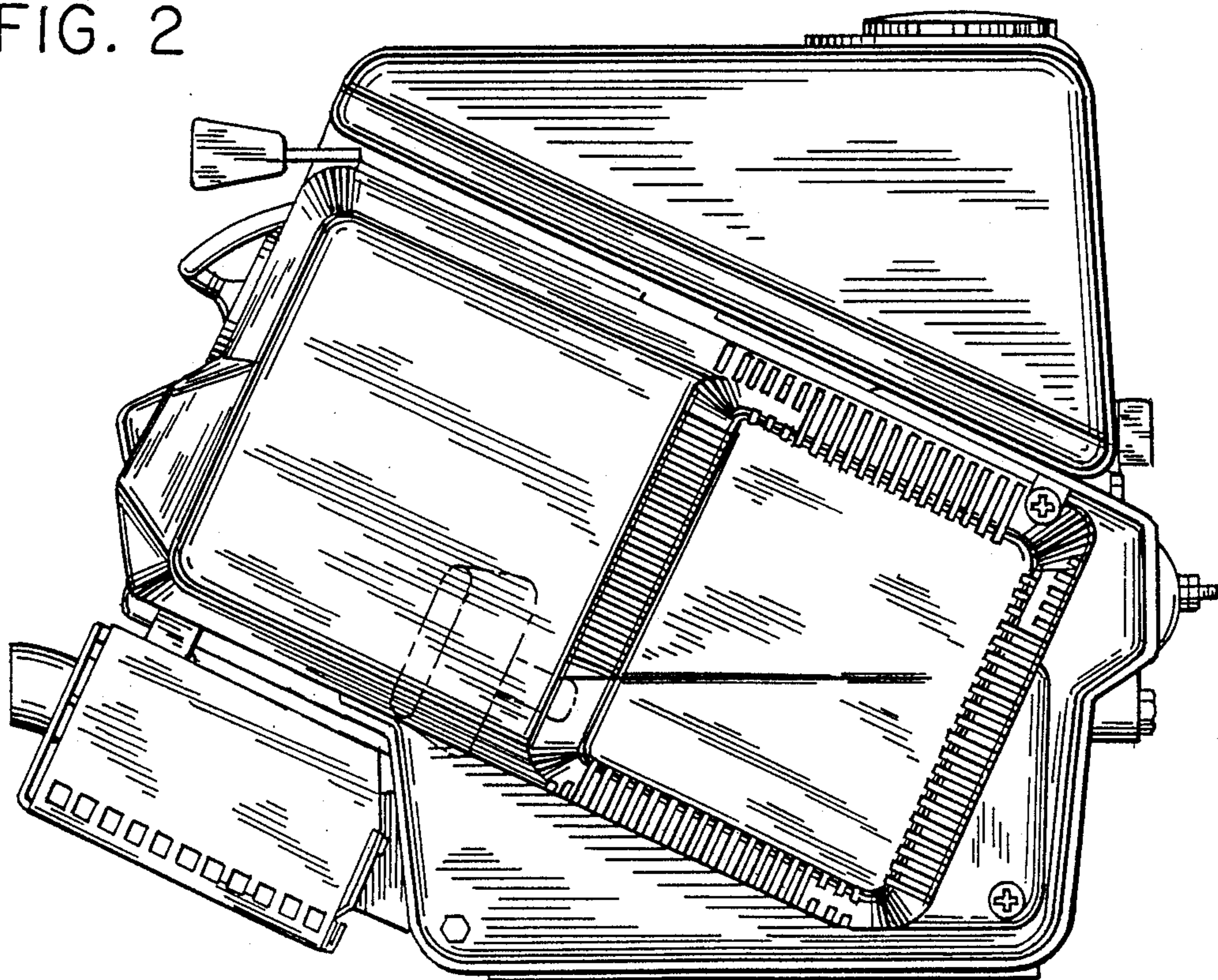

FIG. 1

FIG. 2



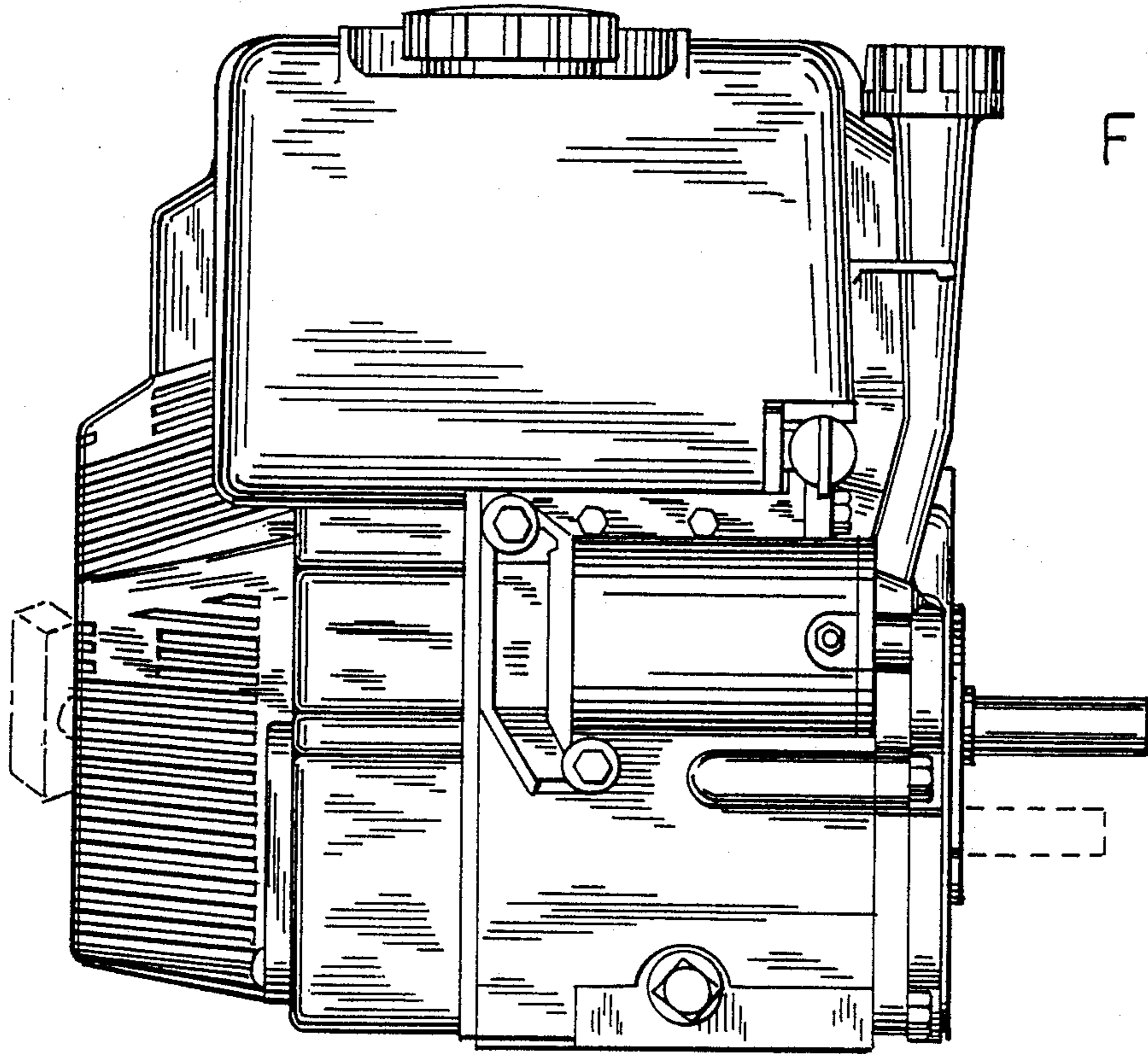

FIG. 3

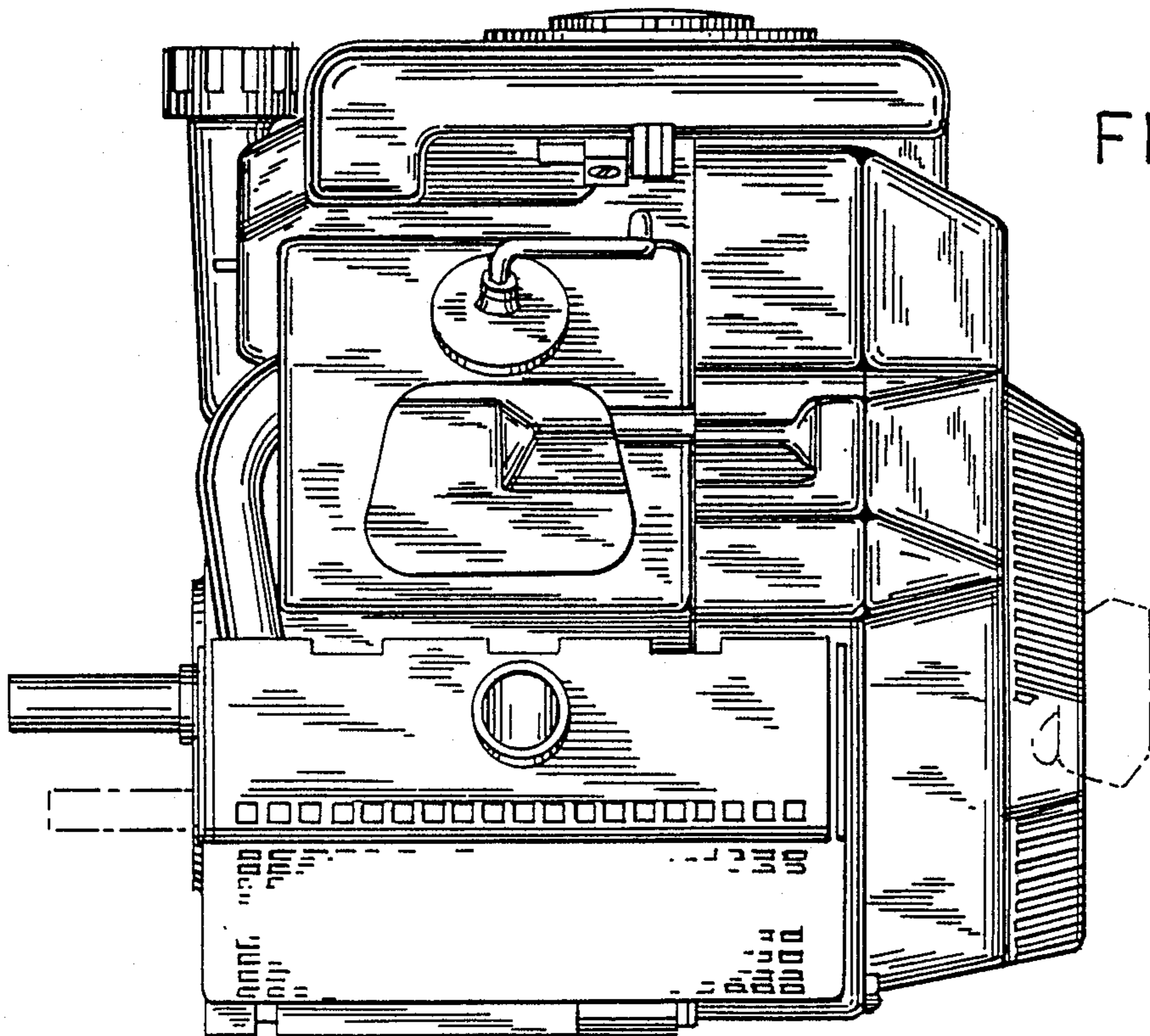

FIG. 4

FIG. 5

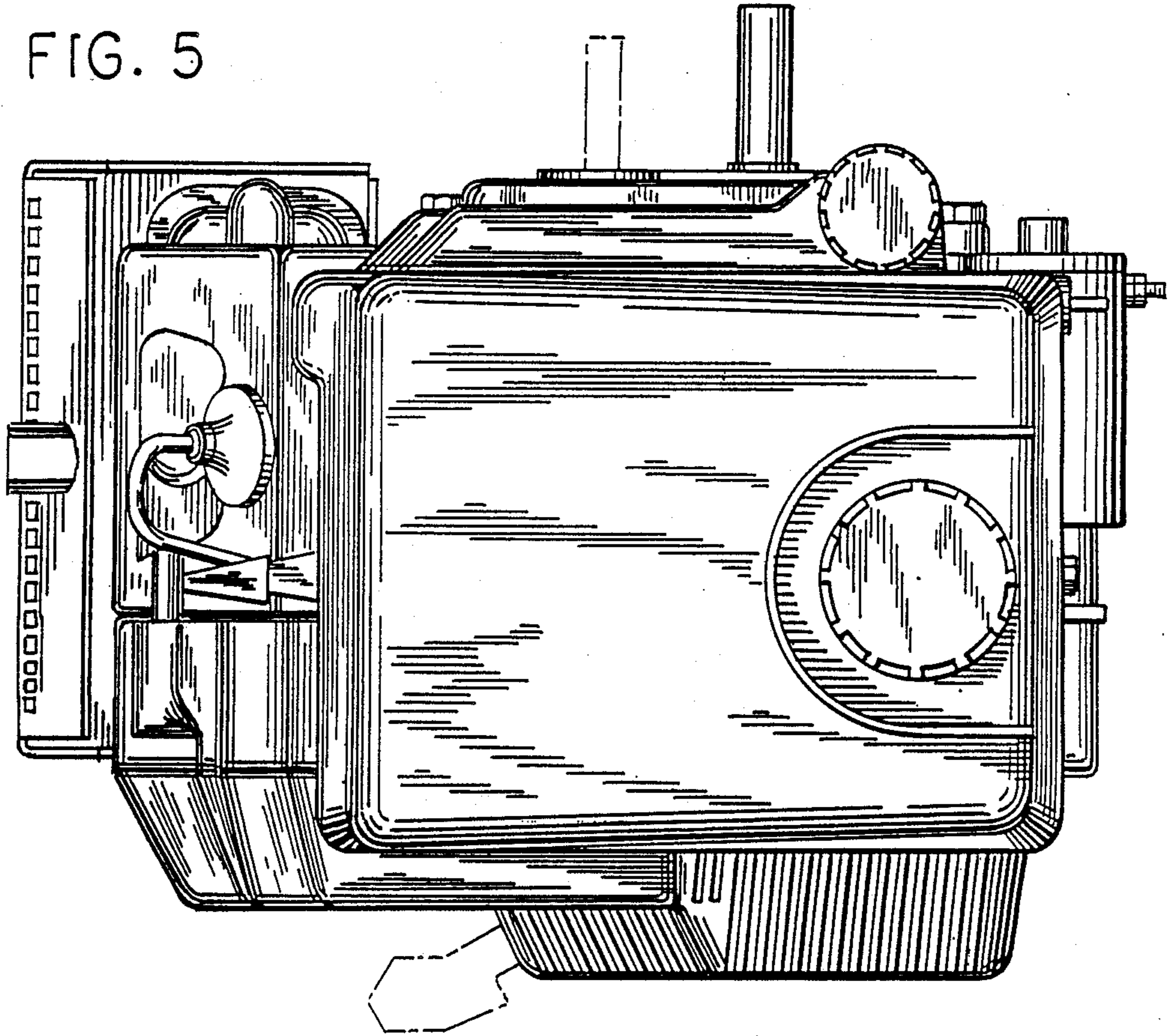

FIG. 6

