

[54] MOTORCYCLE REAR TRUNK UNIT

[75] Inventors: Toshiyuki Yamada, Saitama; Eiji Hamano, Tokyo, both of Japan

[73] Assignee: Honda Giken Kogyo Kabushiki Kaisha, Tokyo, Japan

[**] Term: 14 Years

[21] Appl. No.: 123,431

[22] Filed: Nov. 20, 1987

[52] U.S. Cl. D12/158

[58] Field of Search D12/158; 224/32 R, 32 A

[56] References Cited

U.S. PATENT DOCUMENTS

- D. 244,927 7/1977 Anthon, III D12/158
- D. 300,427 2/1989 Yamada et al. D12/158
- 4,809,891 2/1989 Patrin 224/32 R

OTHER PUBLICATIONS

- Cycle World, Jul. 1987, p. 50, BMW K100LT Motorcycle Rear Trunk.
- Cycle World, Mar. 1987, p. 100, Suzuki Cavalcade LXE Motorcycle Rear Trunk.
- Cycle World, Jun. 1986, pp. 21 & 34, Suzuki Cavalcade & Harley Davidson Motorcycle Rear Trunks.
- Cycle World, Jun. 1986, p. 109, Kawasaki Voyager III Motorcycle Rear Trunk.

Primary Examiner—James M. Gandy
Assistant Examiner—Melody Brown
Attorney, Agent, or Firm—Lyon & Lyon

[57] CLAIM

The ornamental design for a motorcycle rear trunk unit, as shown and described.

DESCRIPTION

FIG. 1 is a side elevation view of a motorcycle rear trunk unit showing my new design, it being understood that the broken lines are for illustrative purposes only and form no part of the claimed design;

FIG. 2 is an enlarged right rear oblique perspective view thereof;

FIG. 3 is an enlarged left rear oblique perspective view thereof;

FIG. 4 is an enlarged left side elevation view thereof;

FIG. 5 is an enlarged right side elevation view thereof;

FIG. 6 is an enlarged rear elevation view thereof;

FIG. 7 is an enlarged front elevation view thereof.

FIG. 8 is an enlarged top plan view thereof;

FIG. 9 is a right rear oblique perspective view of a motorcycle rear trunk unit showing a second embodiment of my new design;

FIG. 10 is a left side elevation view of FIG. 9;

FIG. 11 is a rear elevation view of FIG. 9;

FIG. 12 is a front elevation view of FIG. 9;

FIG. 13 is a top plan view of FIG. 9;

FIG. 14 is a right rear oblique perspective view of a motorcycle rear trunk unit showing a third embodiment of my new design;

FIG. 15 is a left side elevation view of FIG. 14;

FIG. 16 is a rear elevation view of FIG. 14;

FIG. 17 is a front elevation view of FIG. 14; and

FIG. 18 is a top plan view of FIG. 14.

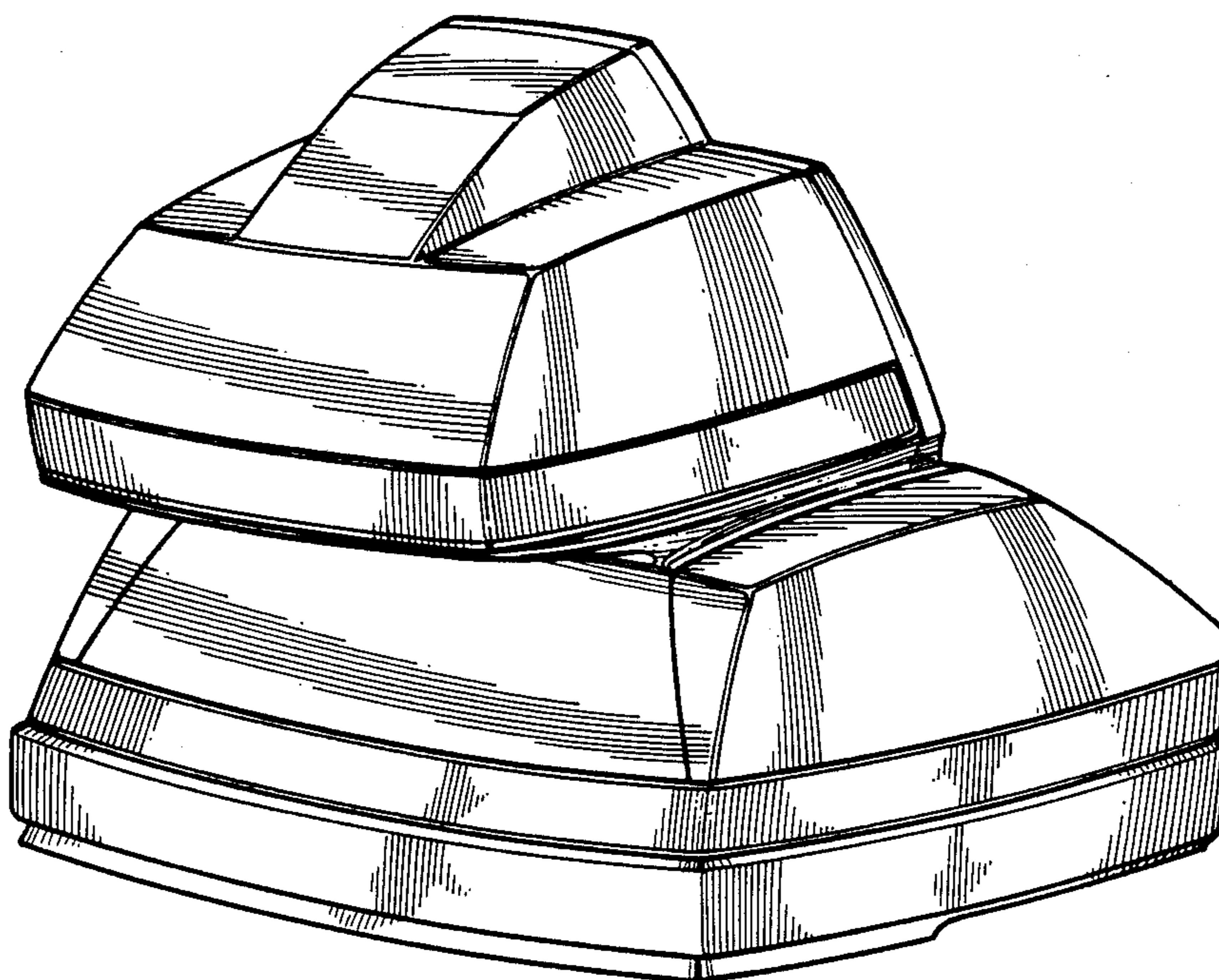

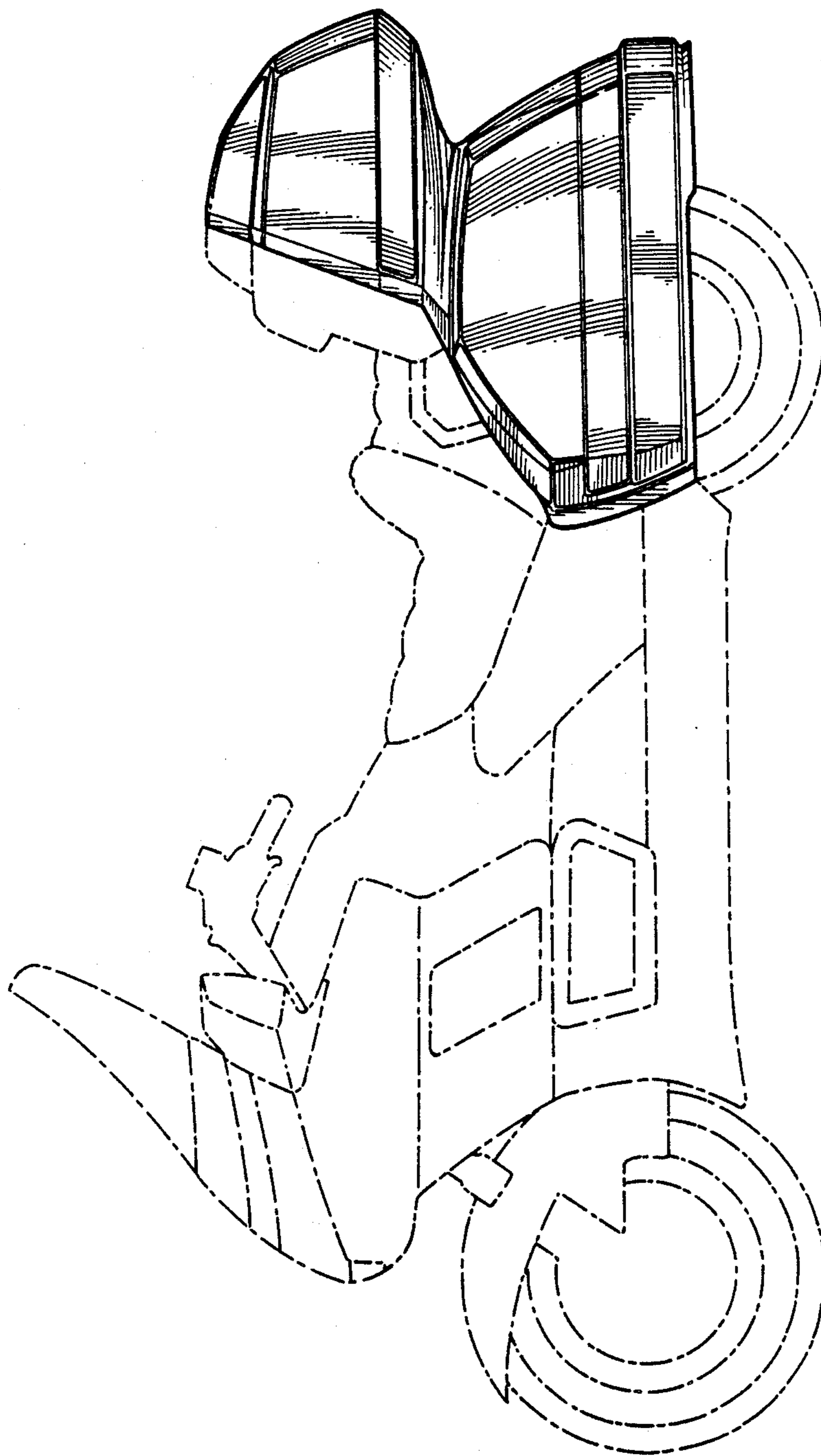

FIG. 1.

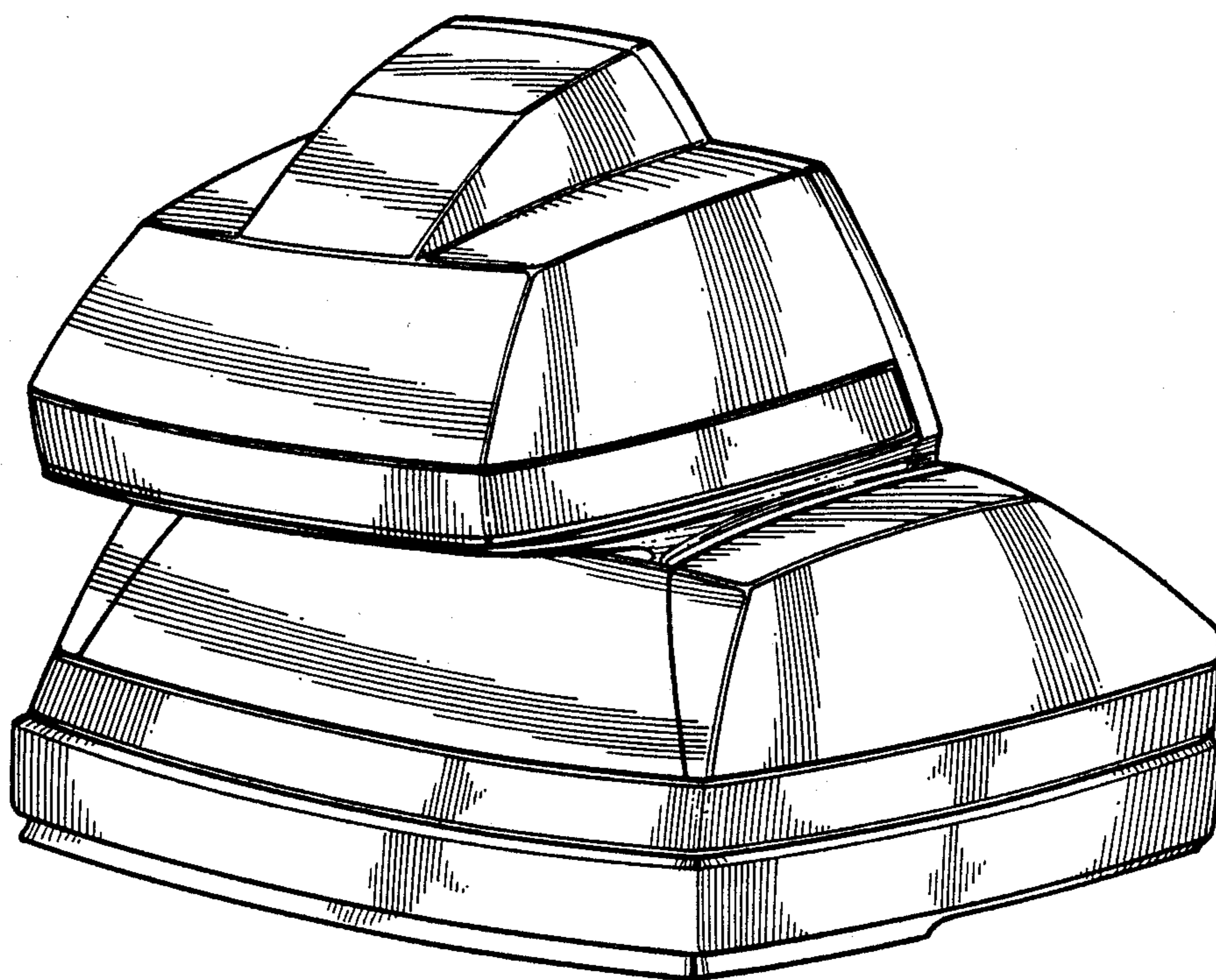

FIG. 2.

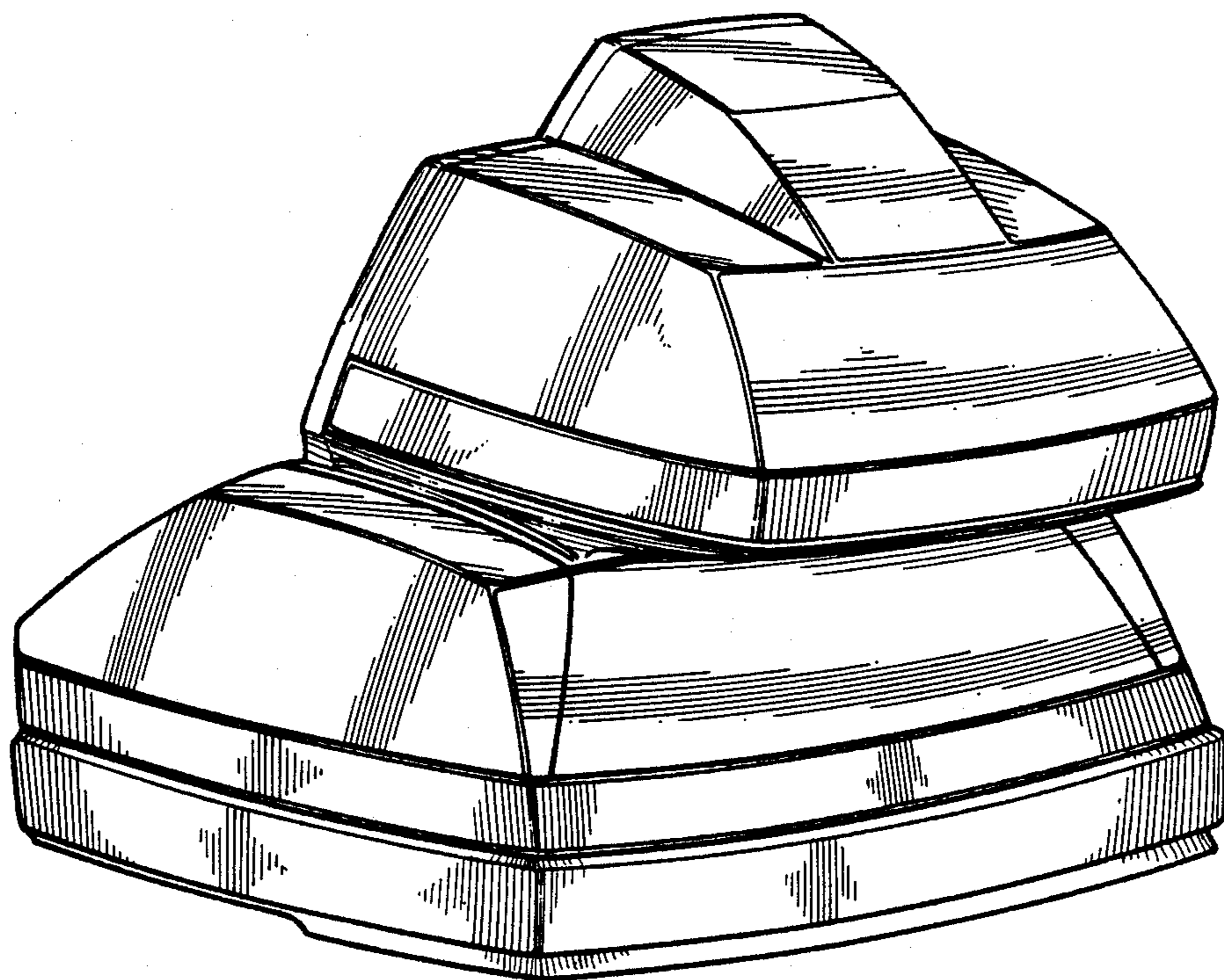

FIG. 3 .

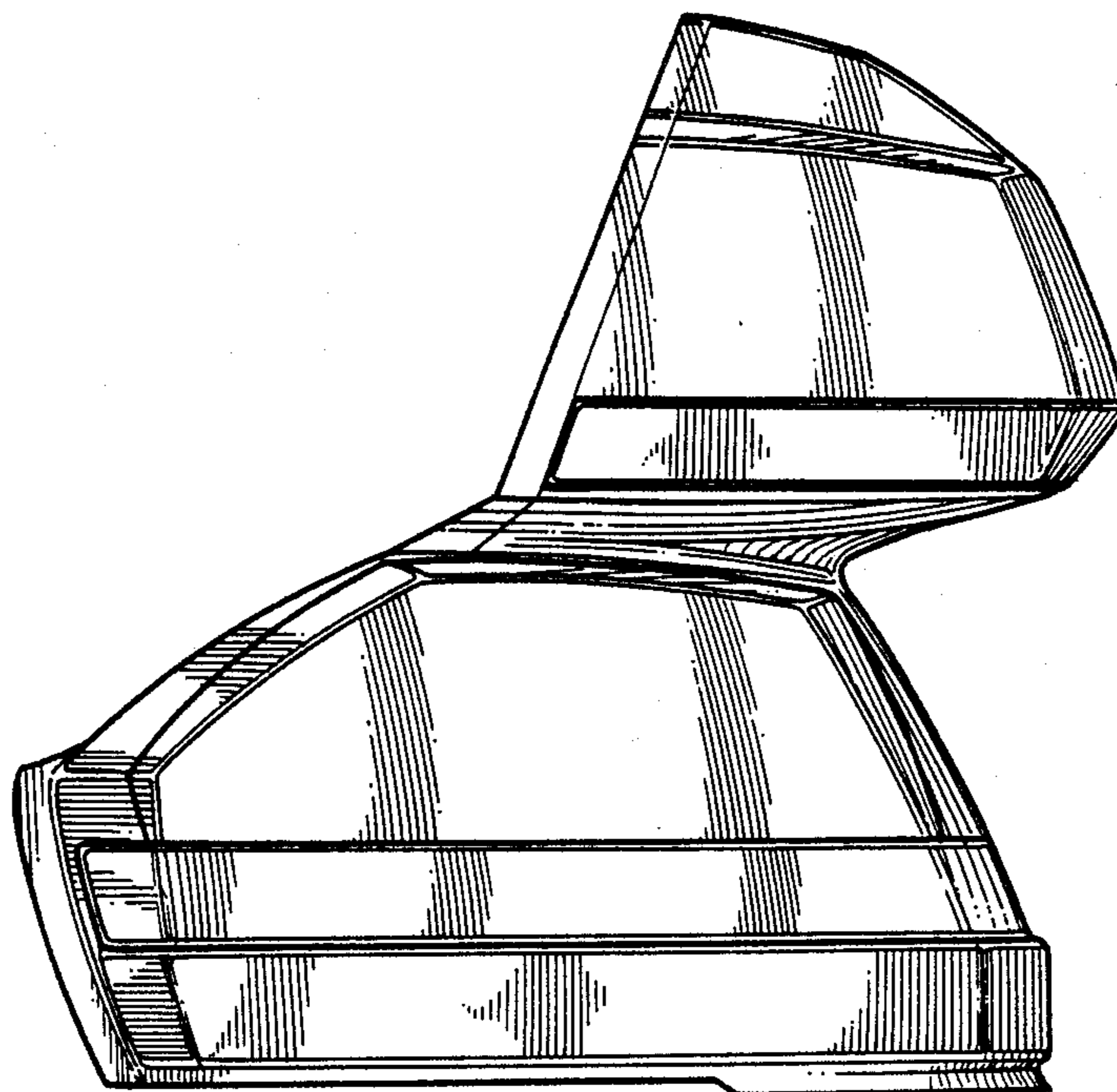

FIG. 4.

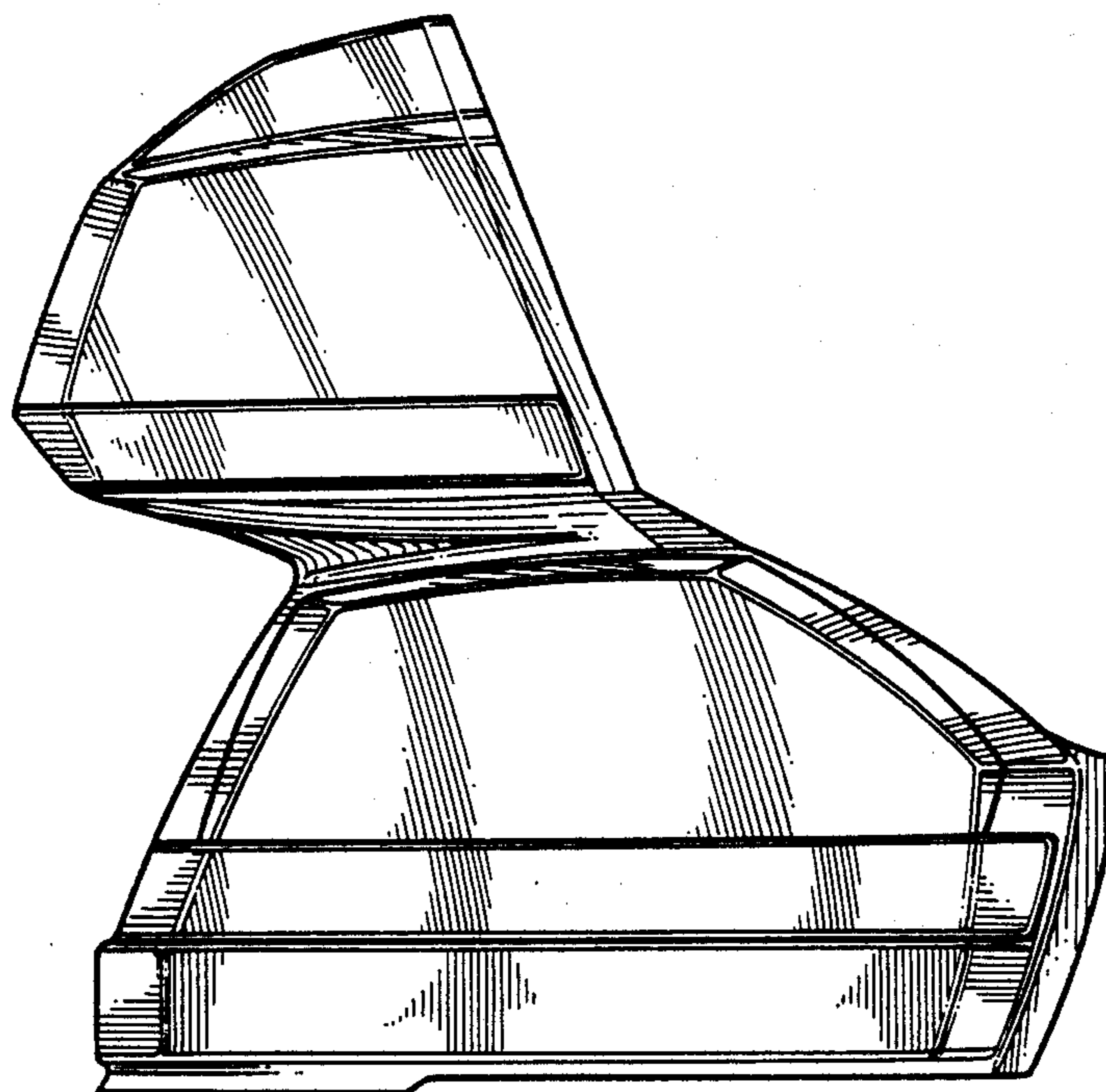

FIG. 5.

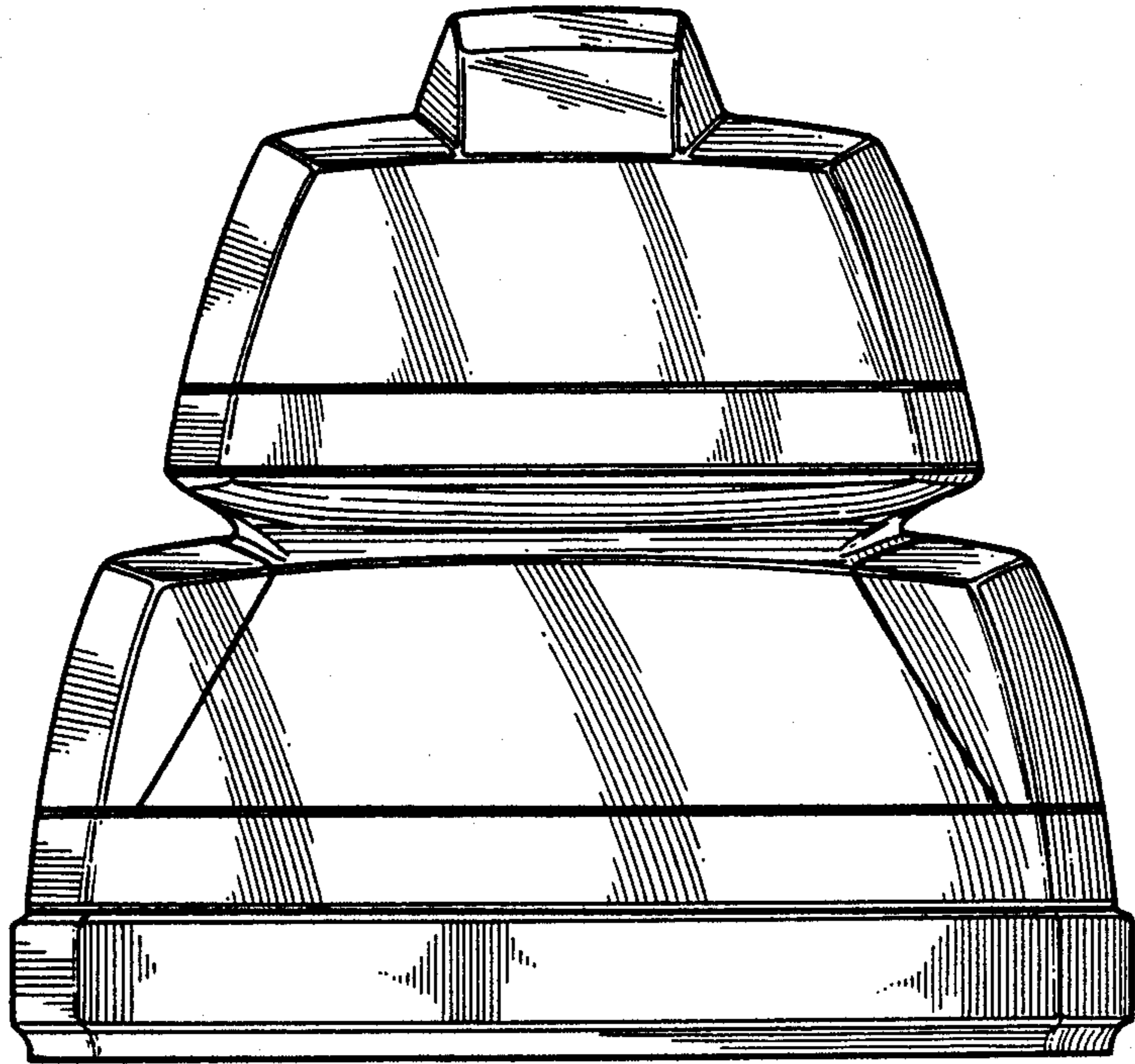

FIG. 6.

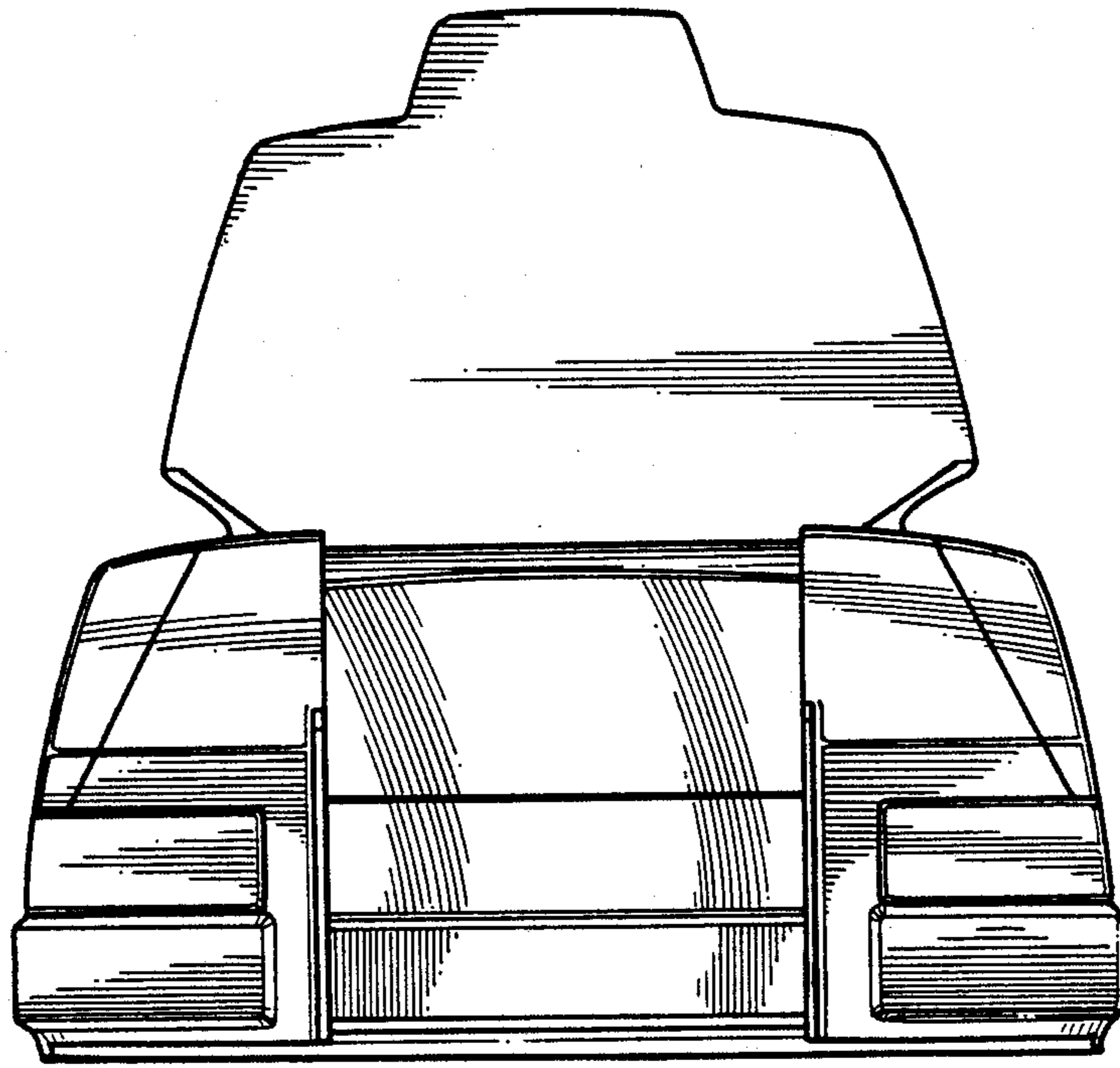

FIG. 7.

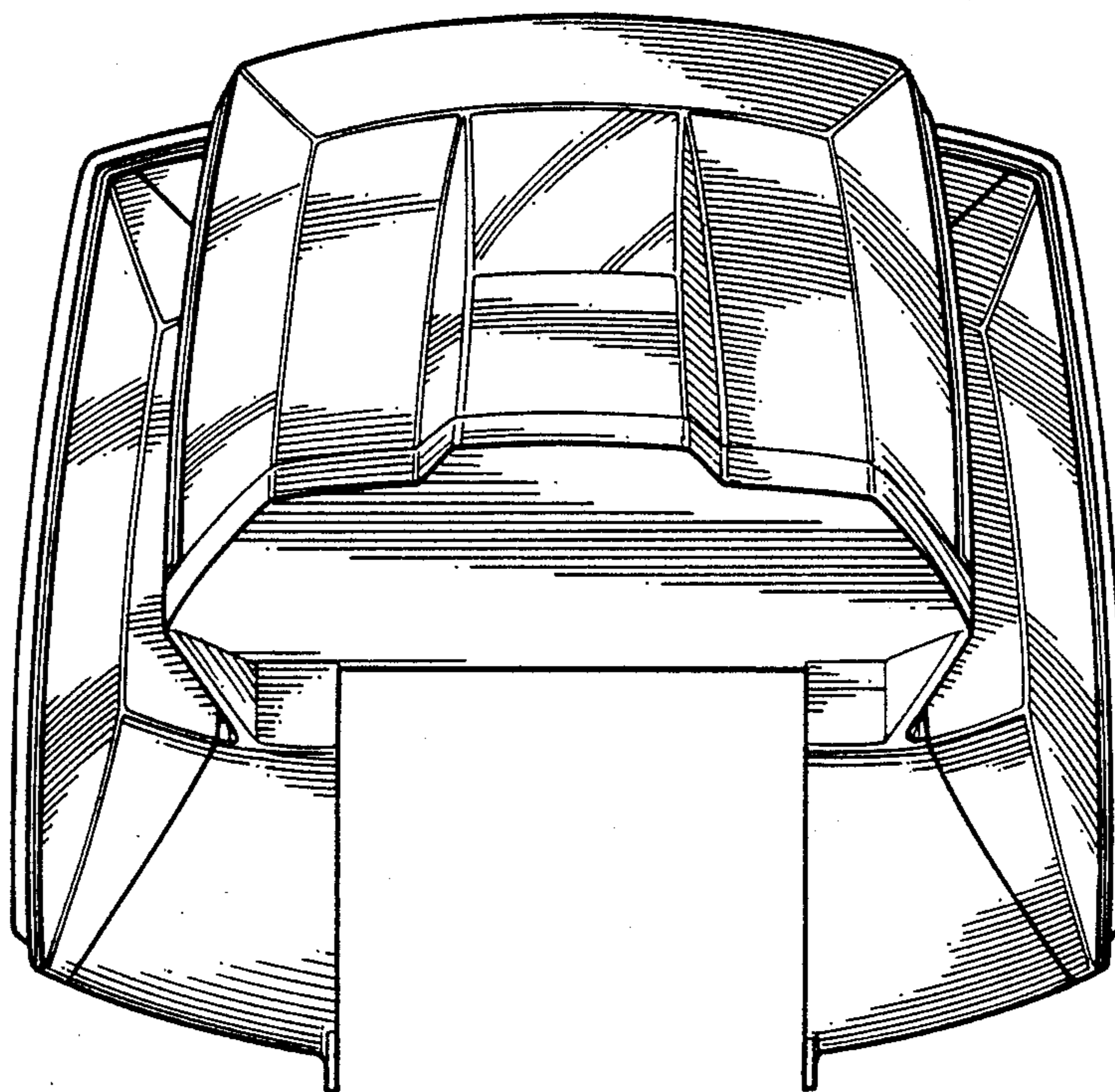

FIG. 8.

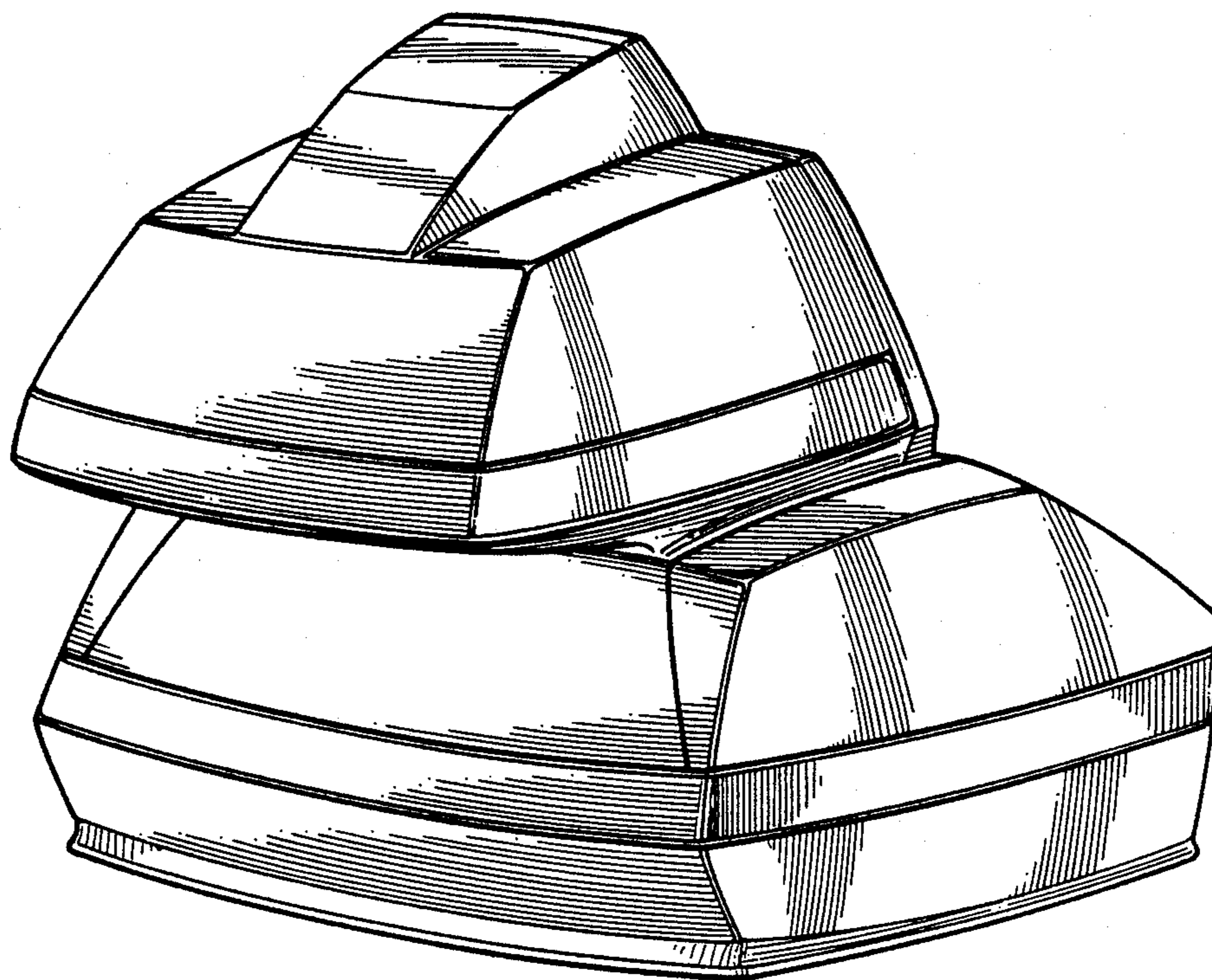

FIG. 9.

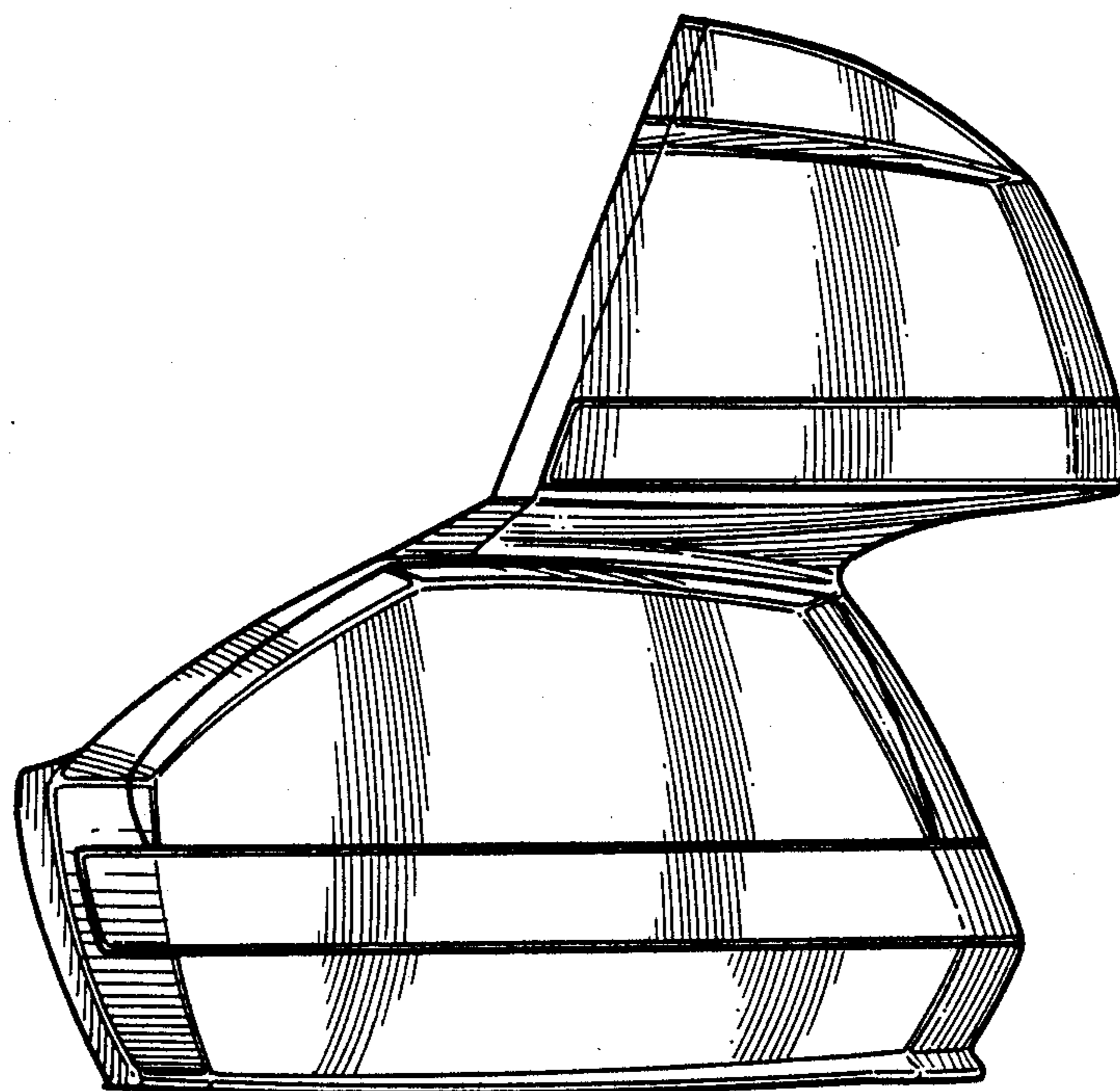

FIG. 10.

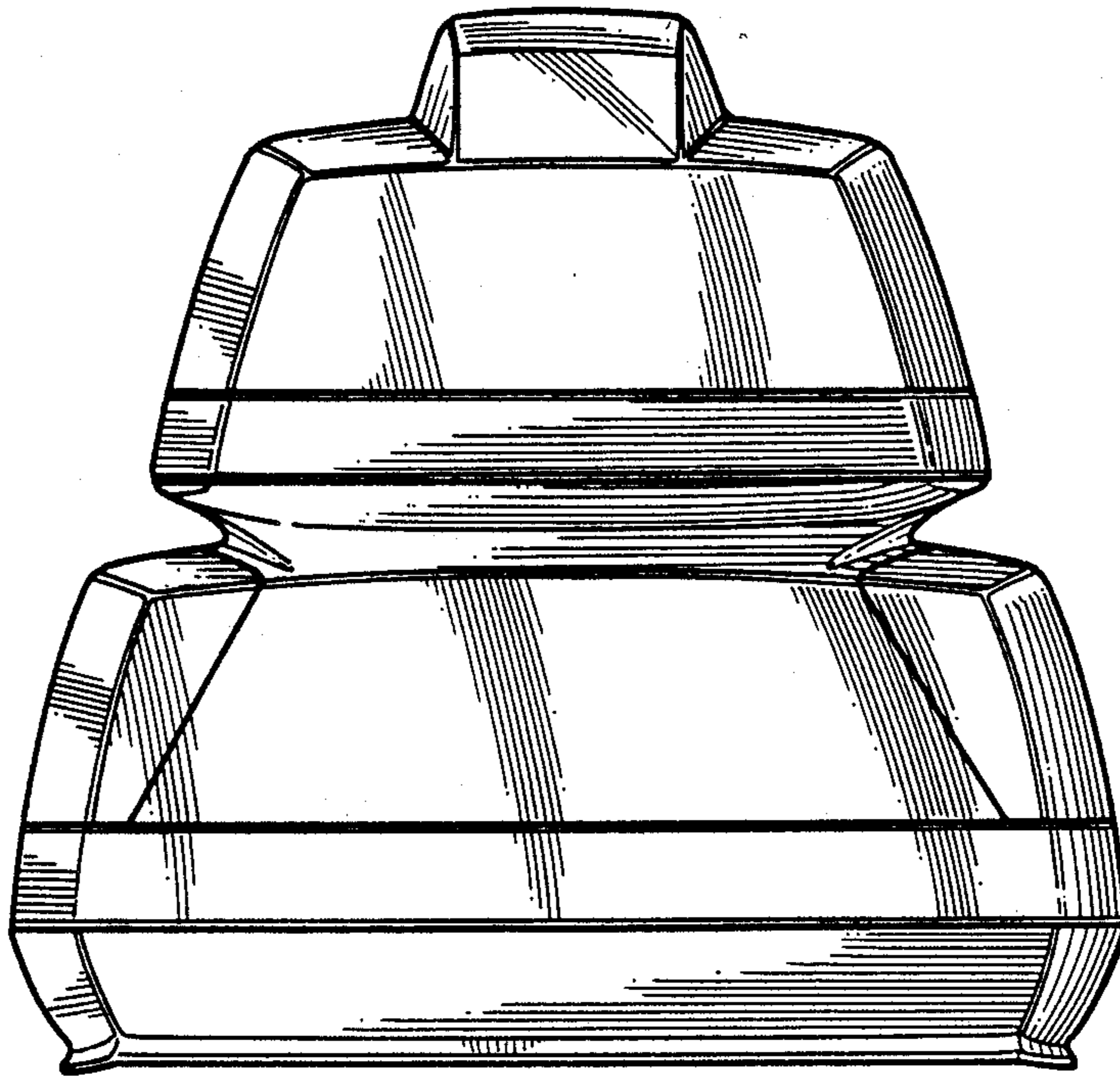

FIG. II.

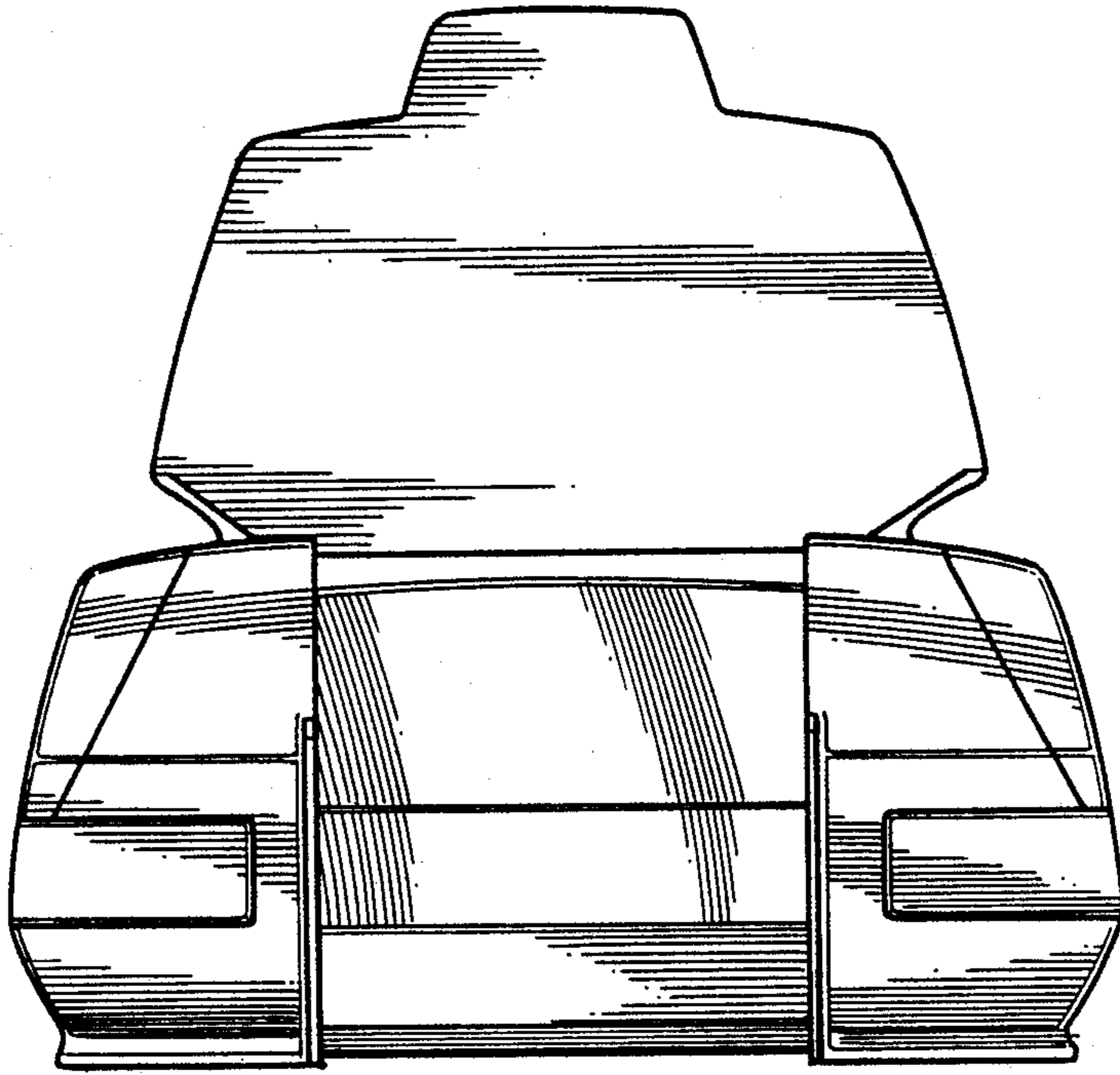

FIG. 12.

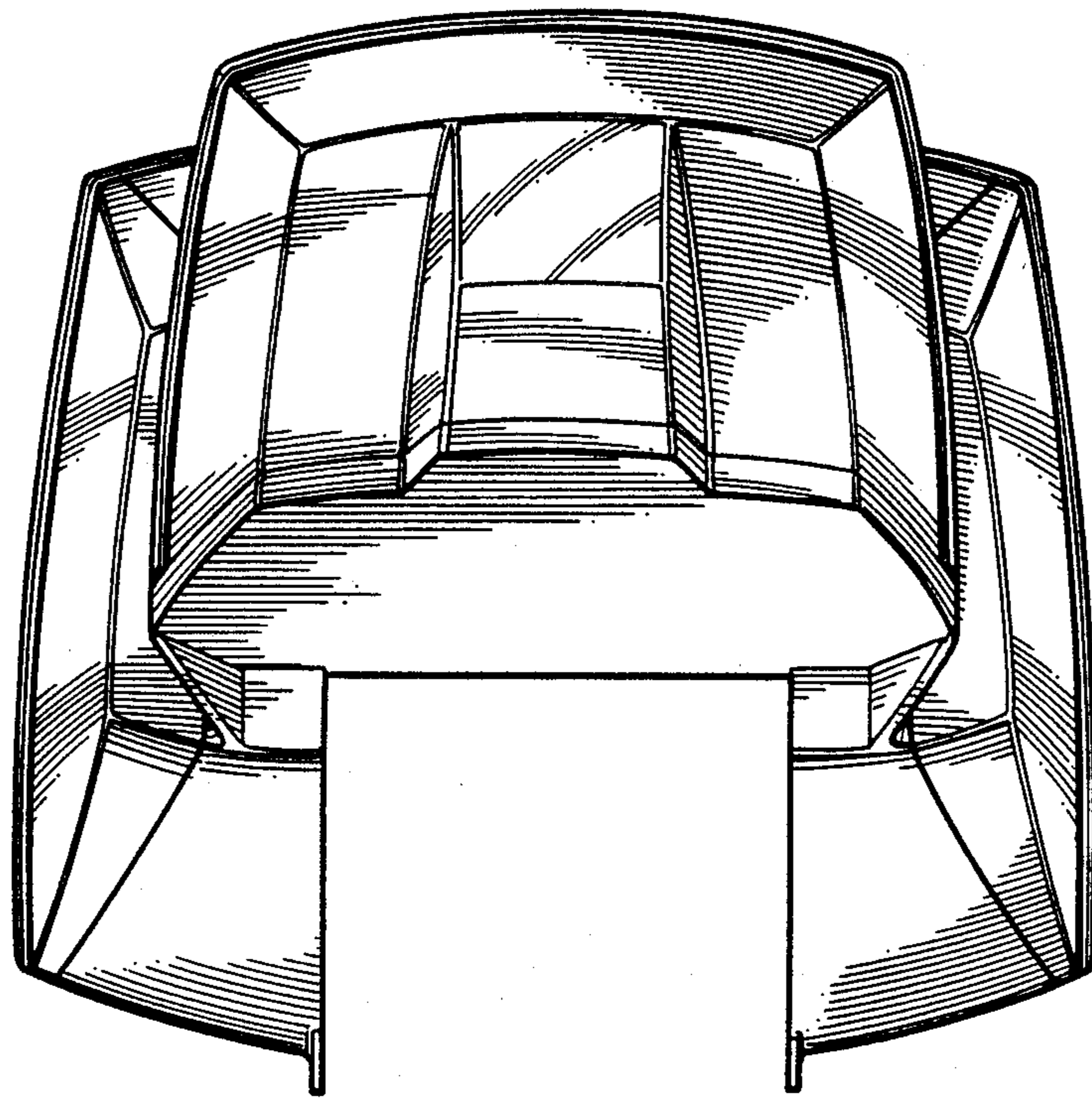

FIG. 13.

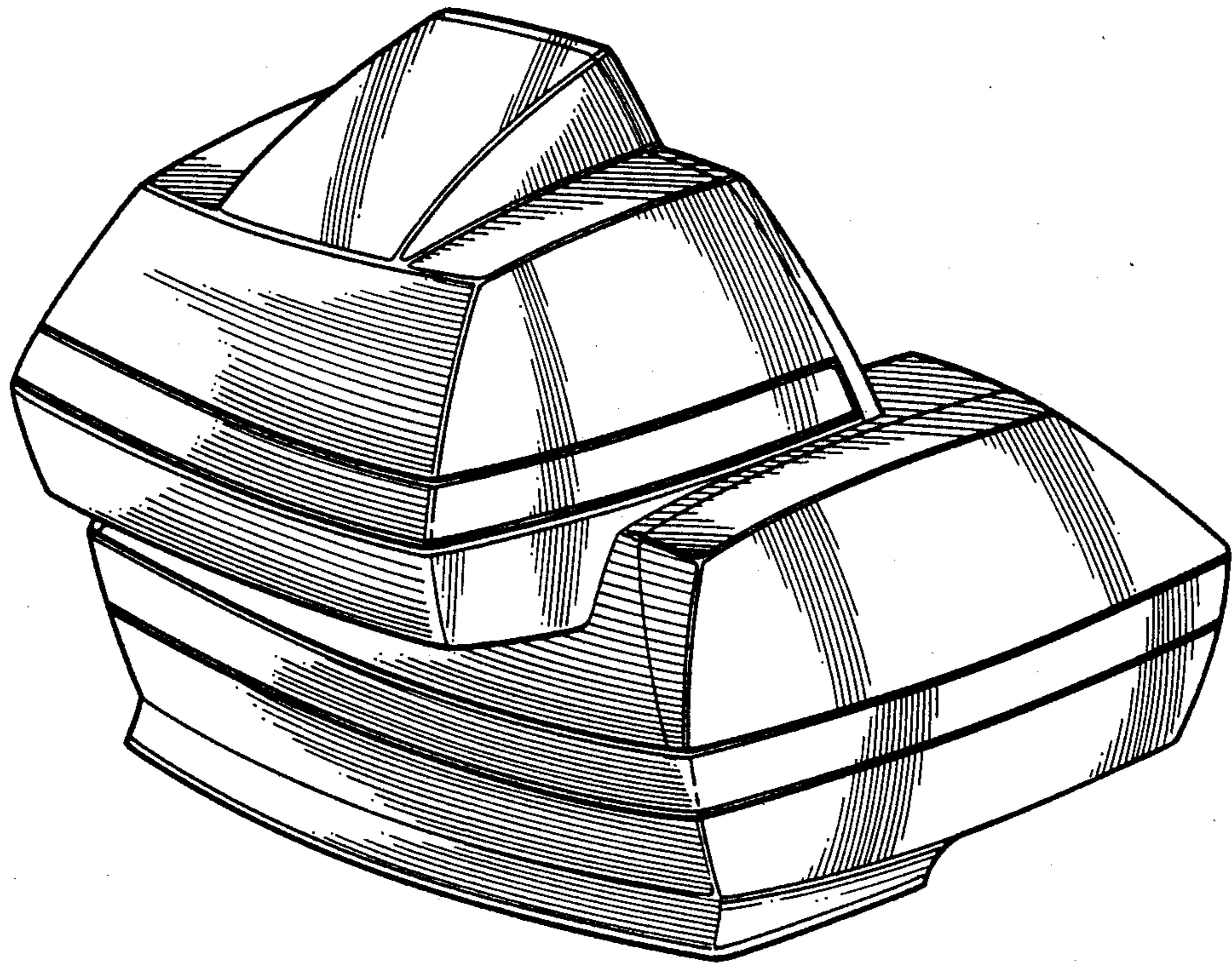

FIG. 14.

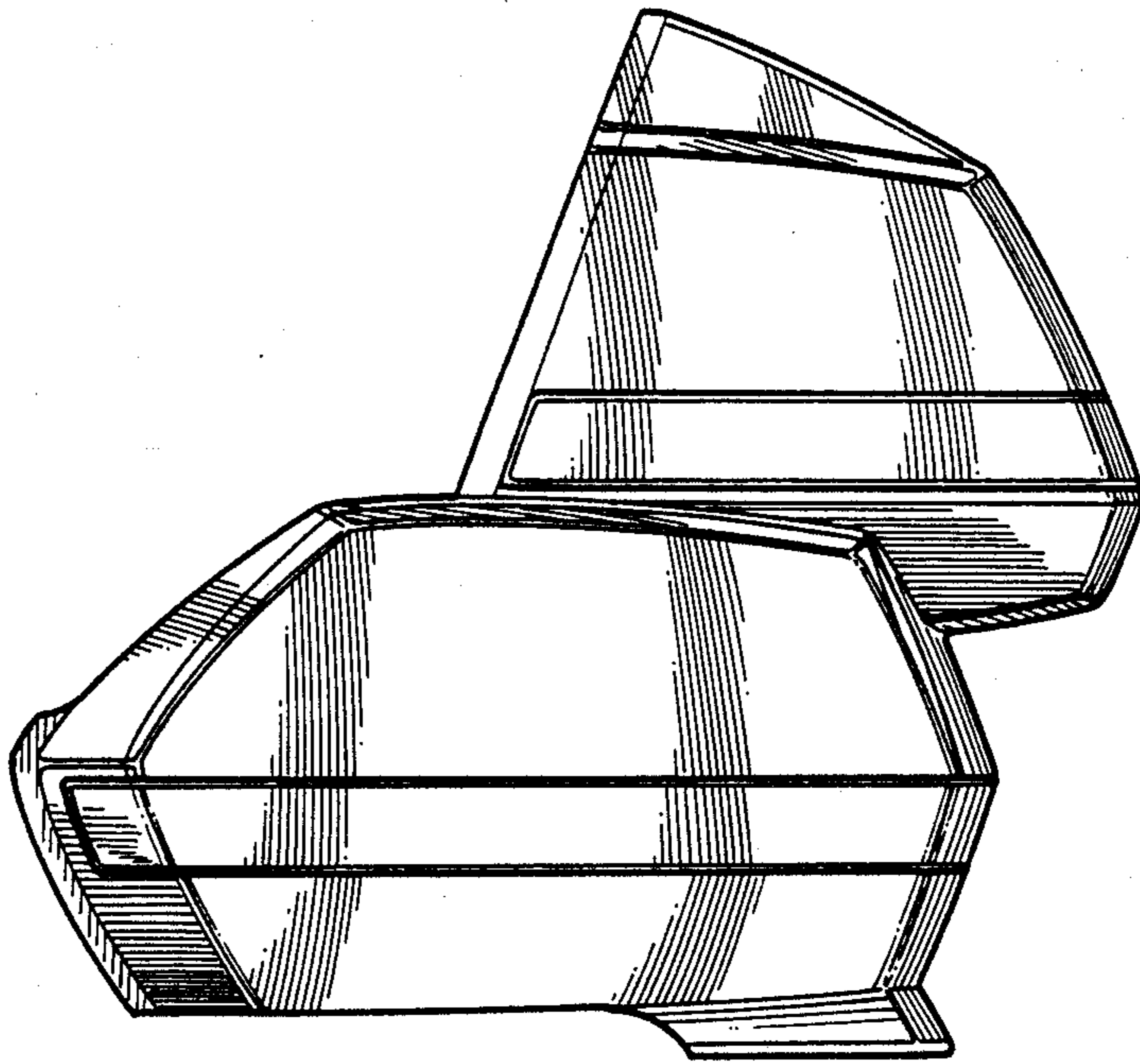

FIG. 15.

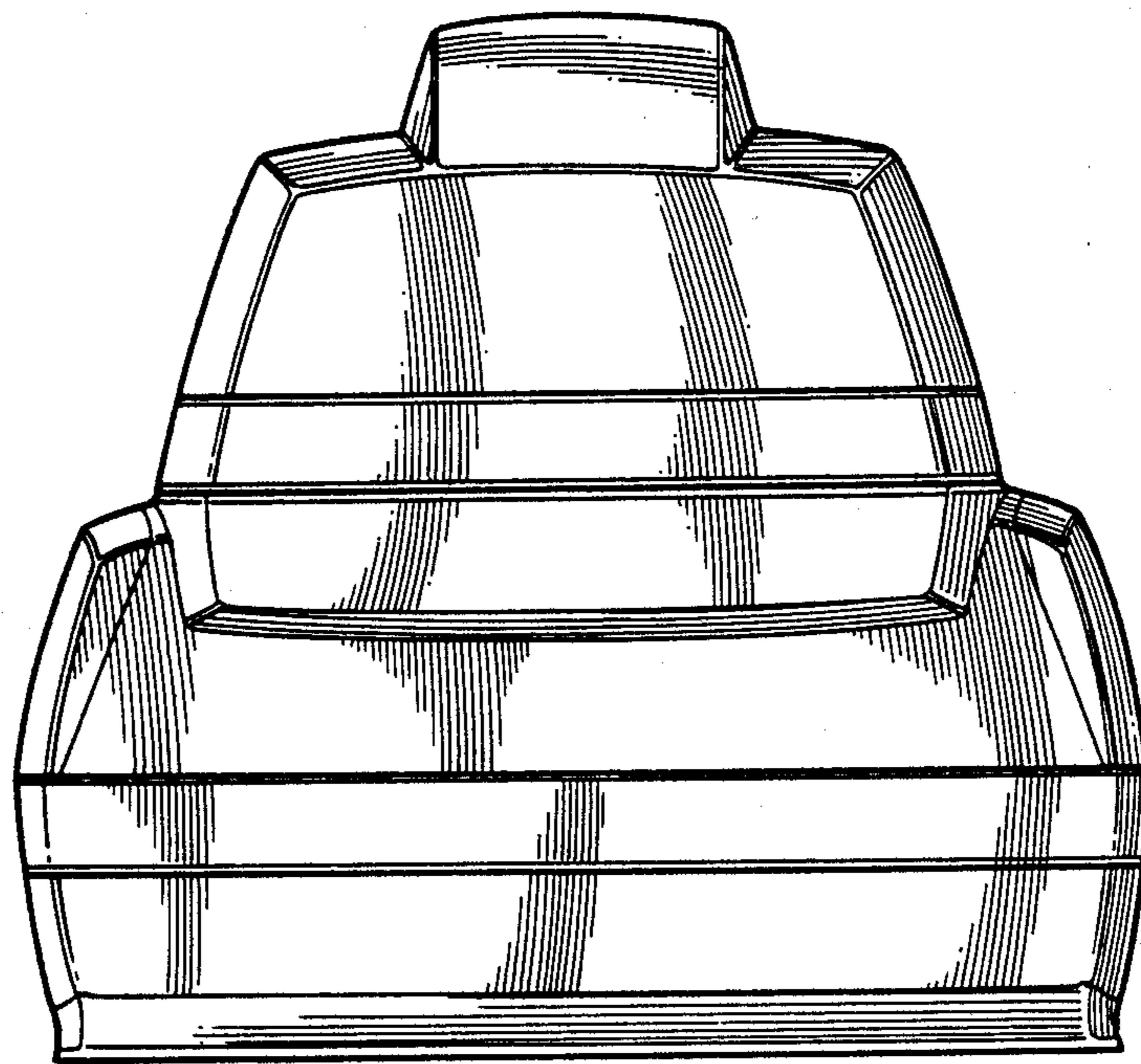

FIG. 16.

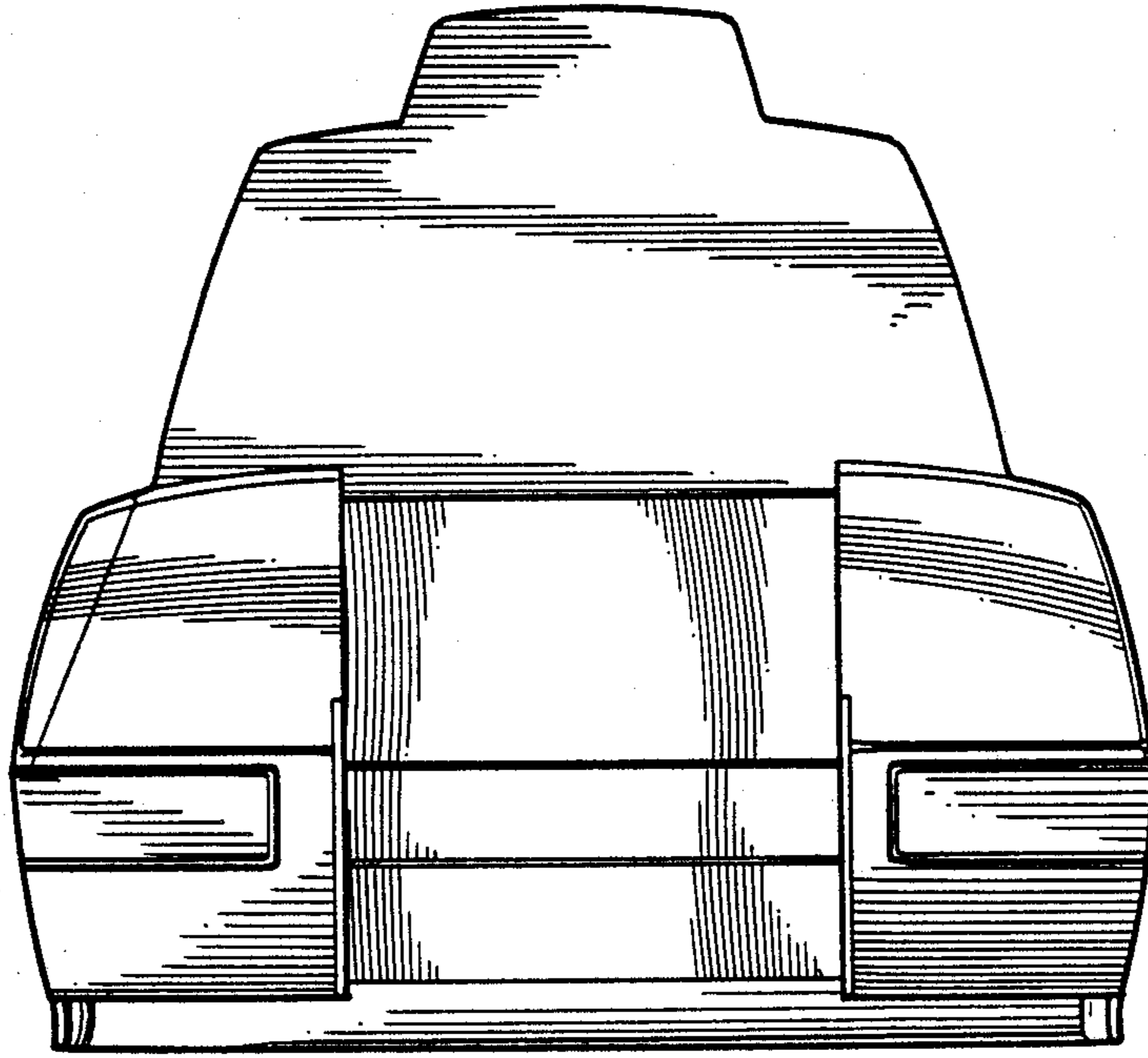

FIG. 17.

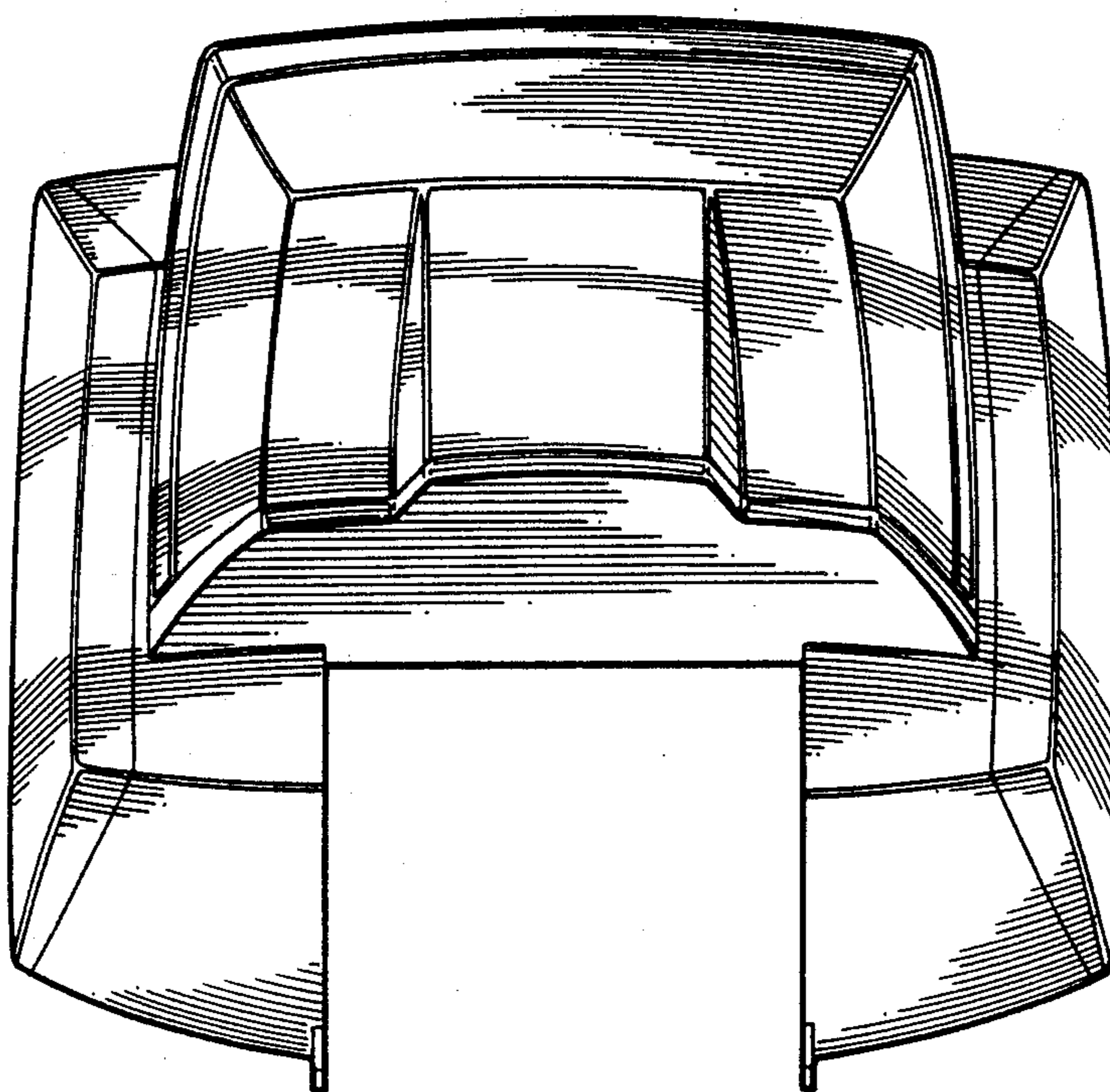

FIG. 18.