

[54] ARMORED VEHICLE

[76] Inventors: James A. Ottevaere; James C. LeBlanc; Richard S. LeBlanc, all of 2340 Alger, Troy, Mich. 48083

[\*\*] Term: 14 Years

[21] Appl. No.: 864,907

[22] Filed: May 19, 1986

[52] U.S. Cl. .... D12/12

[58] Field of Search ..... D12/12, 13; 89/40.03, 89/36.08

[56] References Cited

U.S. PATENT DOCUMENTS

D. 251,289	3/1979	Larson	.....	D12/12
D. 267,001	11/1982	LeBlanc	.....	D12/12
D. 269,418	6/1983	Appelblatt et al.	.....	D12/12
D. 289,389	4/1987	Picard	.....	D12/12
4,492,282	1/1985	Appelblatt et al.	.....	89/40.03
4,601,230	7/1986	LeBlanc	.....	89/40.03
4,607,562	8/1986	LeBlanc	.....	89/40.03

FOREIGN PATENT DOCUMENTS

1012221	7/1957	German Democratic Rep.	.....	89/40.03
---------	--------	------------------------	-------	----------

Primary Examiner—Wallace R. Burke  
Assistant Examiner—Kay H. Chin  
Attorney, Agent, or Firm—Lalos & Keegan

[57] CLAIM

The ornamental design for an armored vehicle, as shown and described.

DESCRIPTION

FIG. 1 is a front elevational view of an armored vehicle showing our new design;  
 FIG. 2 is a rear elevational view of FIG. 1.  
 FIG. 3 is a top plan view of FIG. 1.  
 FIG. 4 is a left side elevational view of FIG. 1.  
 FIG. 5 is a right side elevational view of FIG. 1.  
 FIG. 6 is a front elevational view of a third embodiment of the armored vehicle.  
 FIG. 7 is a rear elevational view of FIG. 6.  
 FIG. 8 is a top plan view of FIG. 6.  
 FIG. 9 is a left side elevational view of FIG. 6.  
 FIG. 10 is a right side elevational view of FIG. 6.  
 FIG. 11 is a front elevational view of a fourth embodiment of the armored vehicle.  
 FIG. 12 is a rear elevational view of FIG. 11.  
 FIG. 13 is a top plan view of FIG. 11.  
 FIG. 14 is a left side elevational view of FIG. 11.  
 FIG. 15 is a right side elevational view of FIG. 11.  
 FIG. 16 is a front elevational view of a fifth embodiment of the armored vehicle.  
 FIG. 17 is a rear elevational view of FIG. 16.  
 FIG. 18 is a top plan view of FIG. 16.  
 FIG. 19 is a left side elevational view of FIG. 16.  
 FIG. 20 is a right side elevational view of FIG. 16.  
 FIG. 21 is an enlarged perspective view of FIG. 1;  
 FIG. 22 is an enlarged perspective view of FIG. 6;  
 FIG. 23 is an enlarged perspective view of FIG. 11; and  
 FIG. 24 is an enlarged perspective view of FIG. 16.

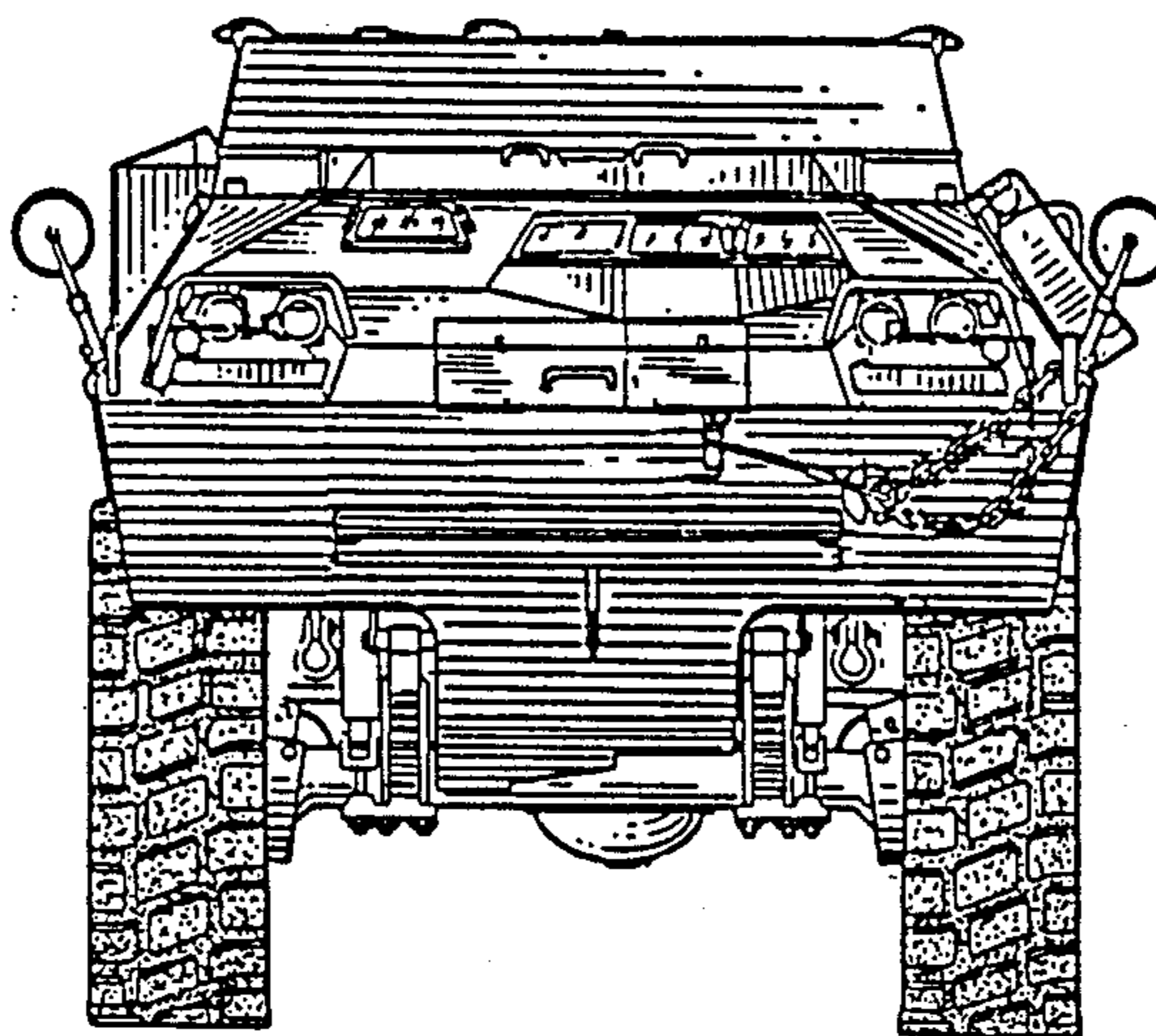


FIG. 1

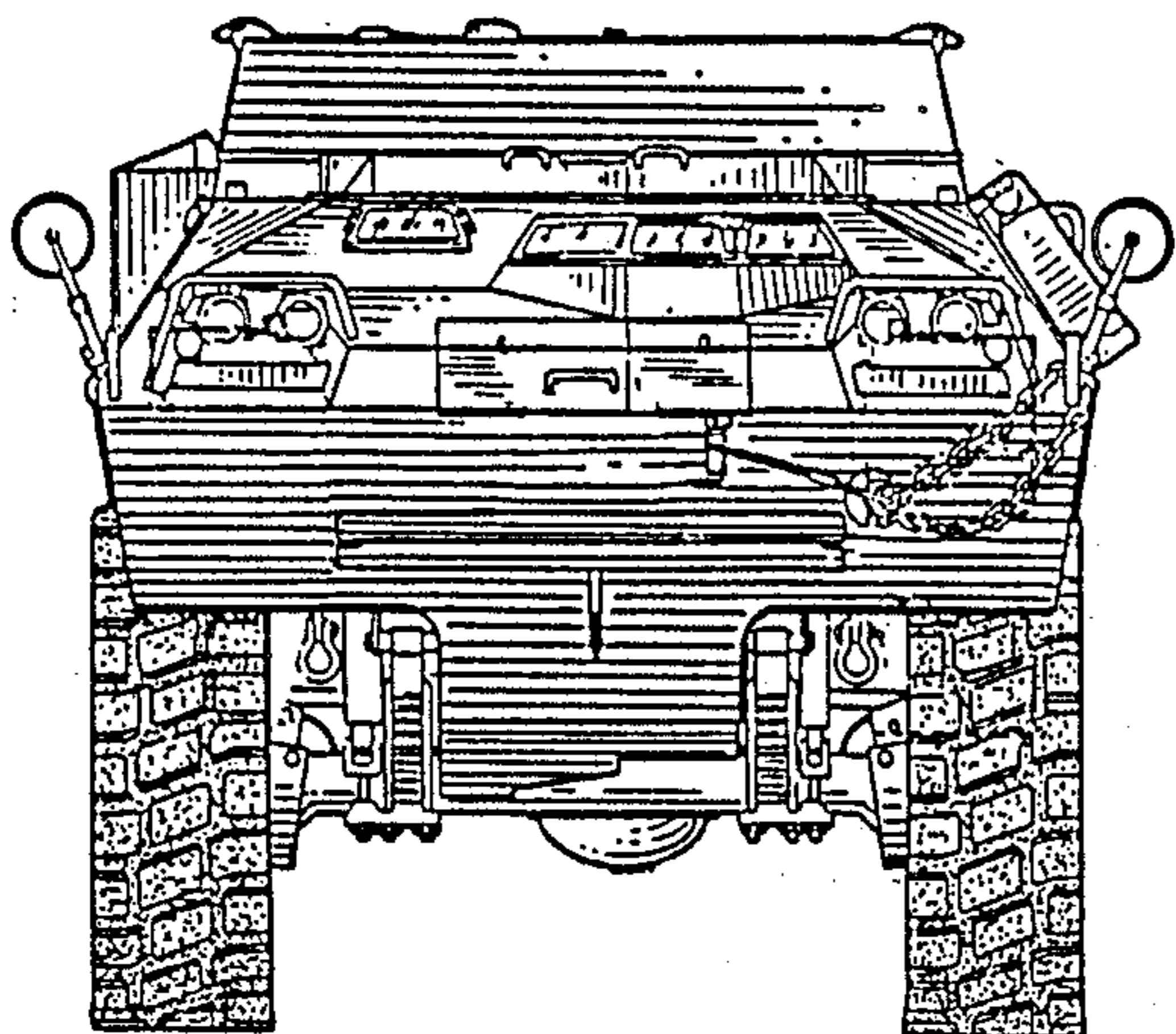


FIG. 2.

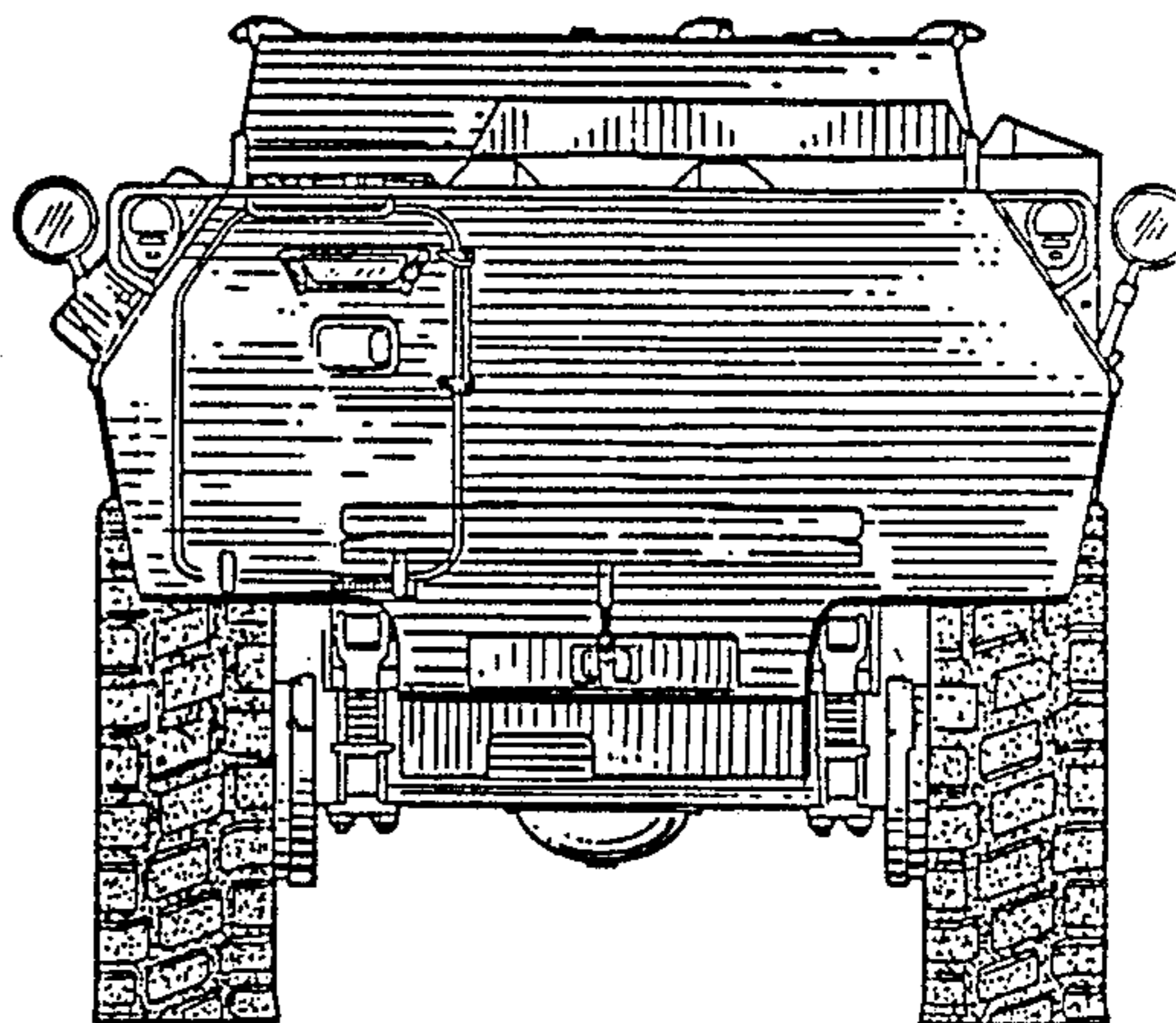
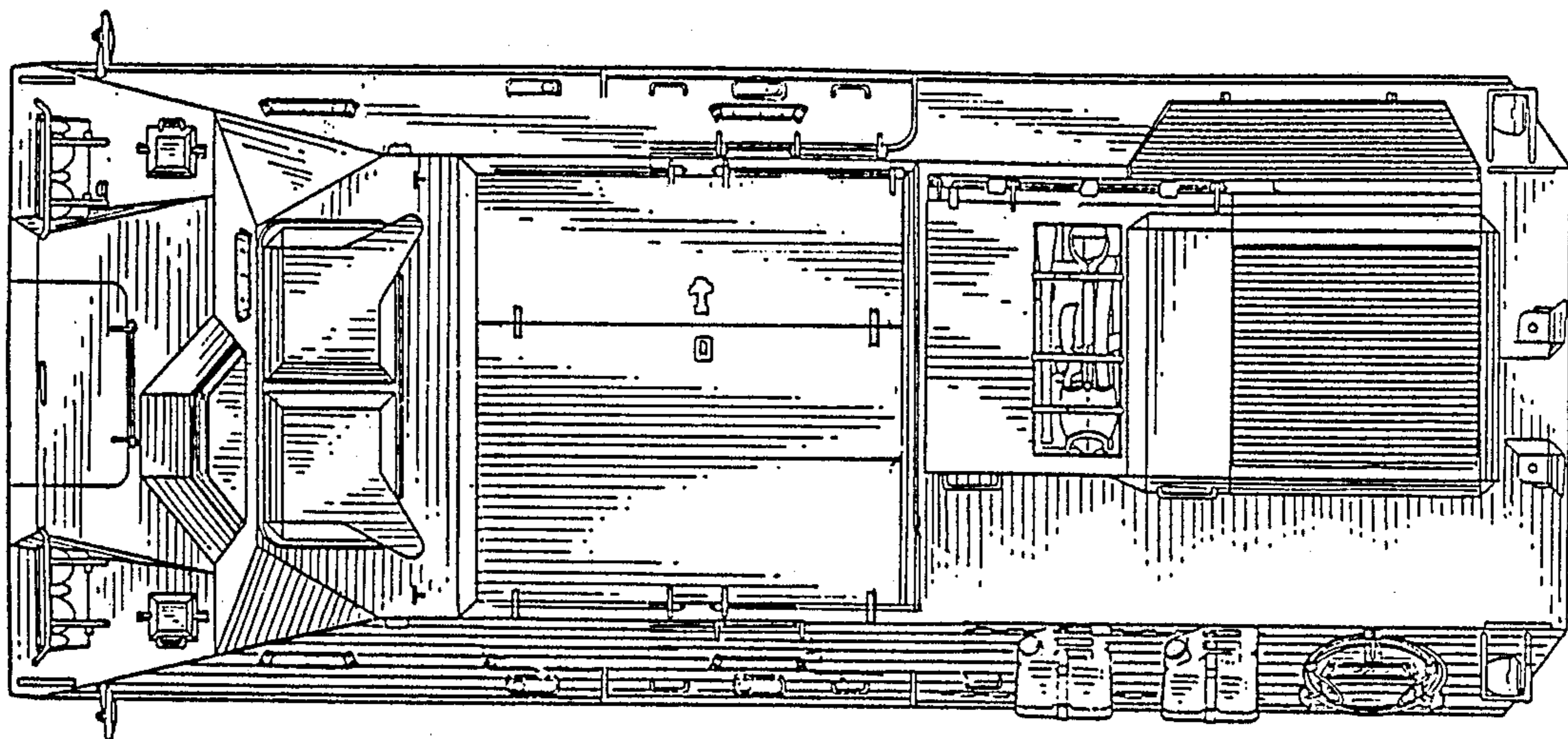
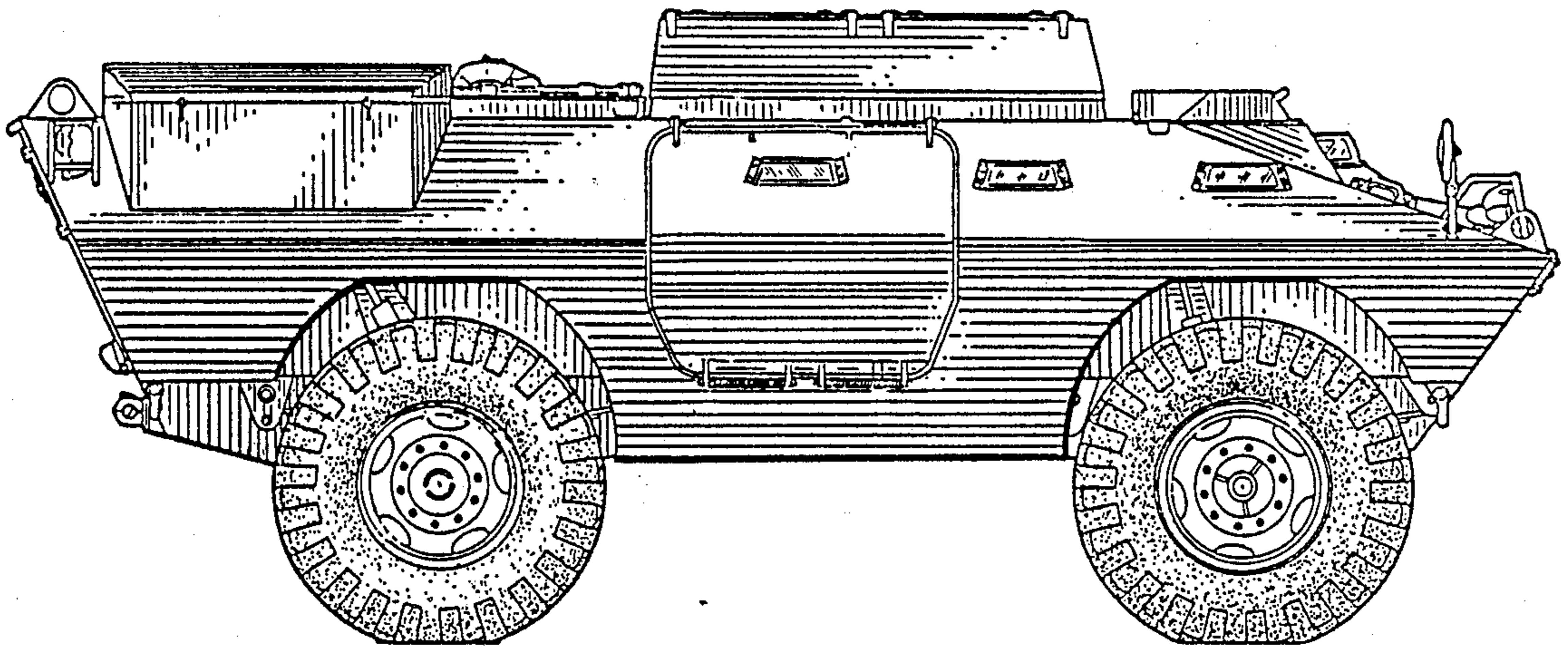


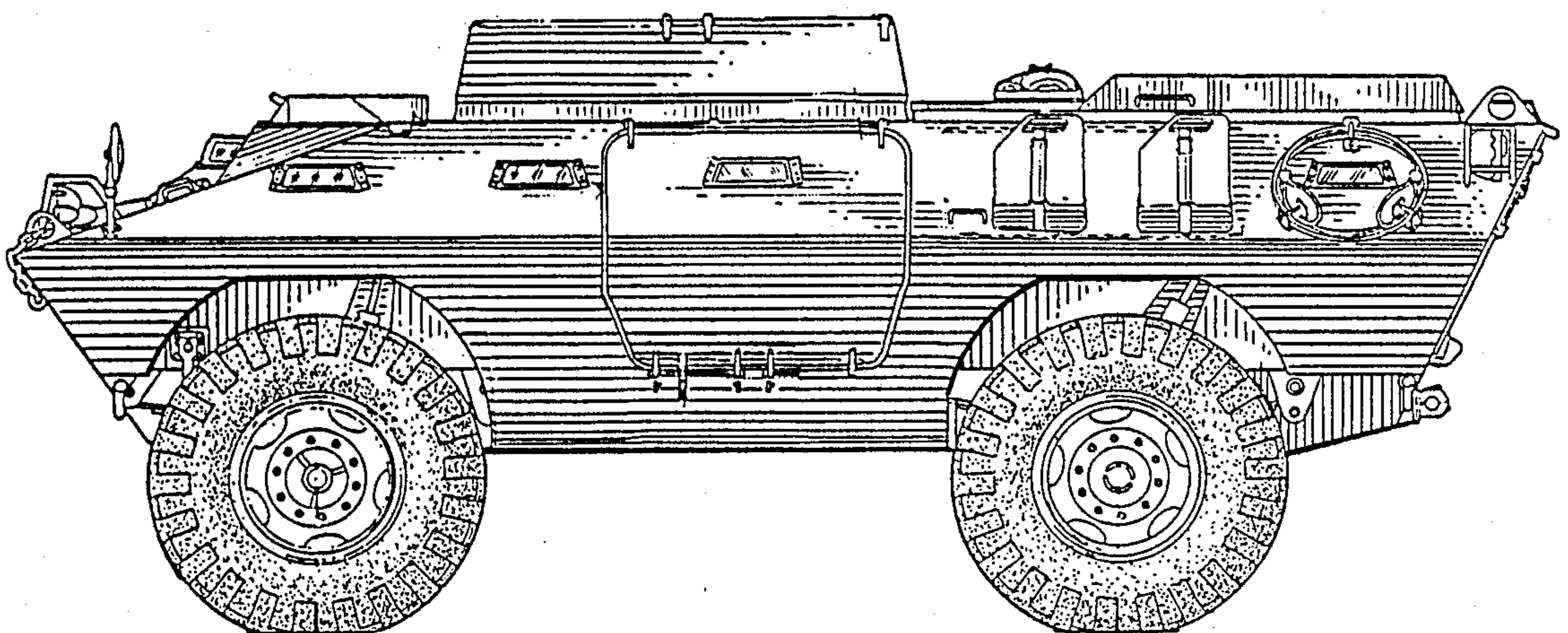
FIG. 3.



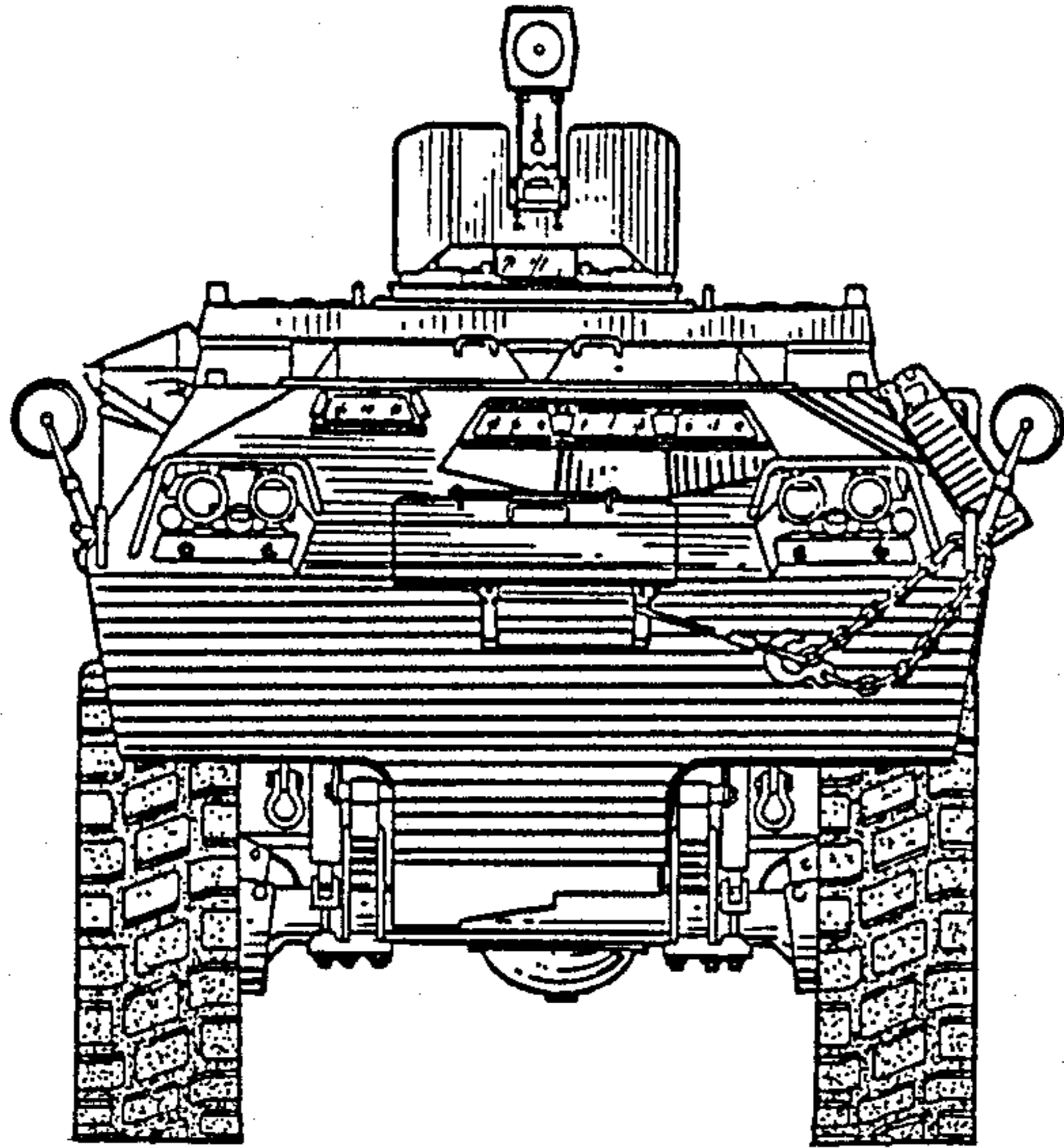
*FIG. 4.*



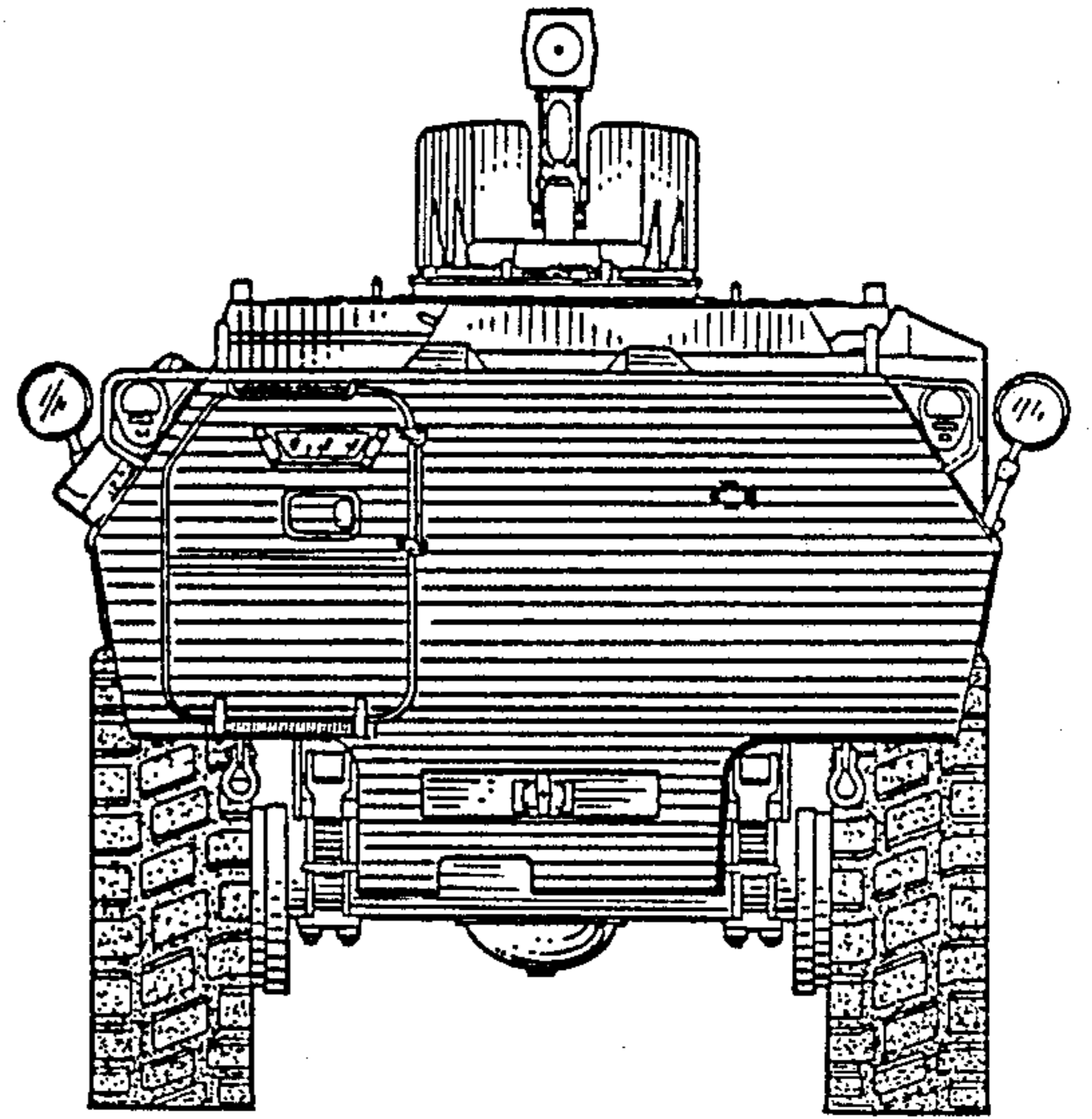
*FIG. 5.*



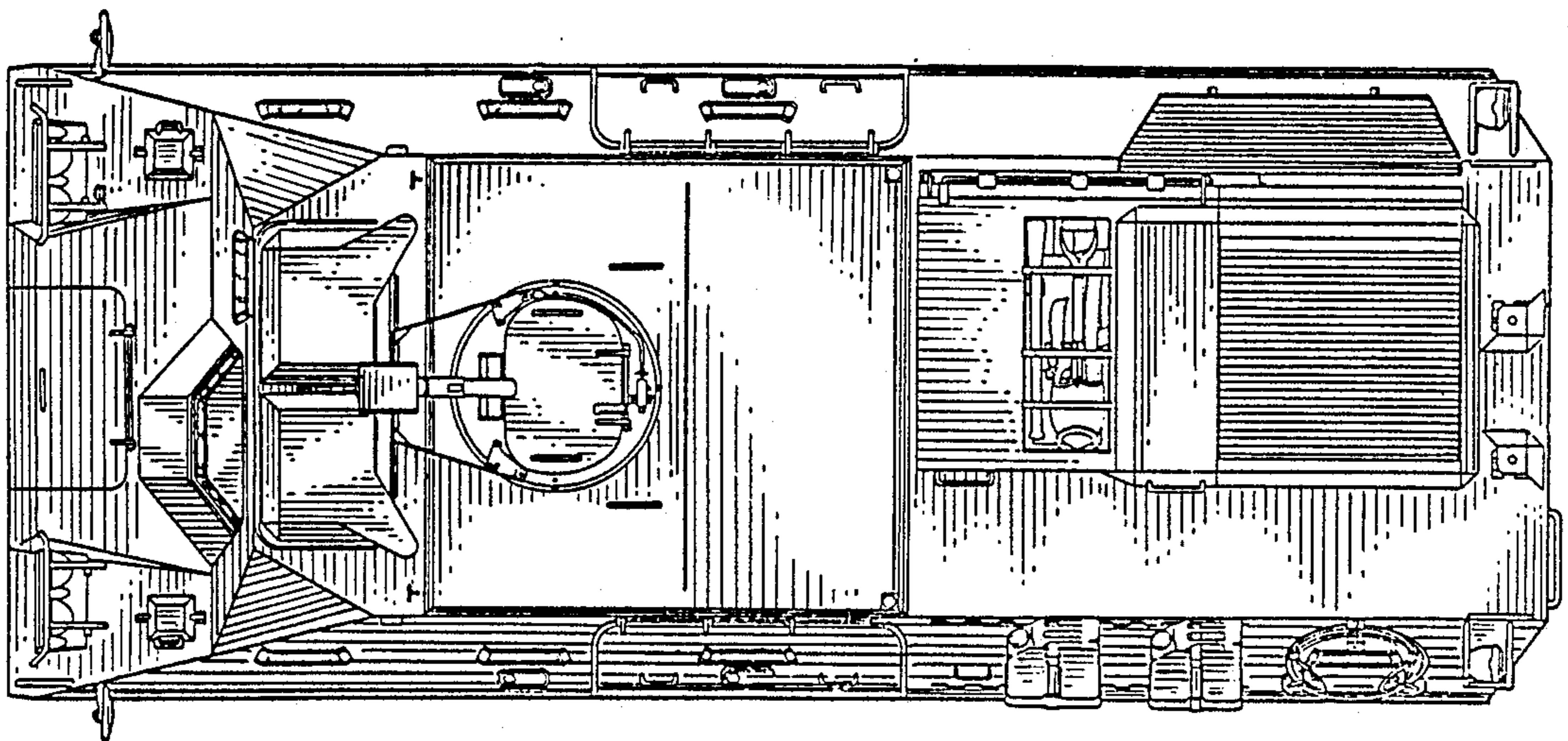
*FIG. 6.*



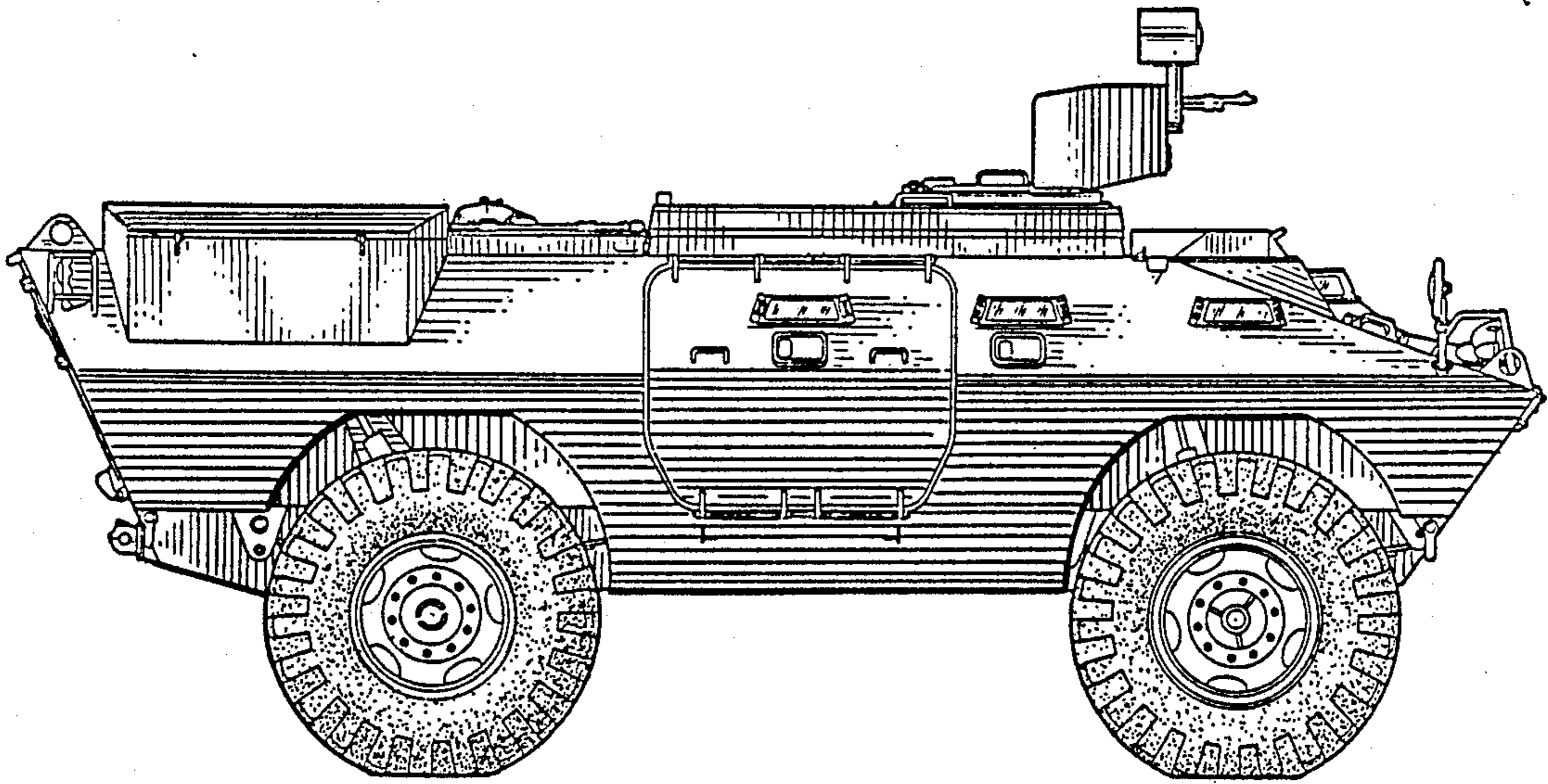
*FIG. 7.*



*FIG. 8.*



*FIG. 9.*



*FIG. 10.*

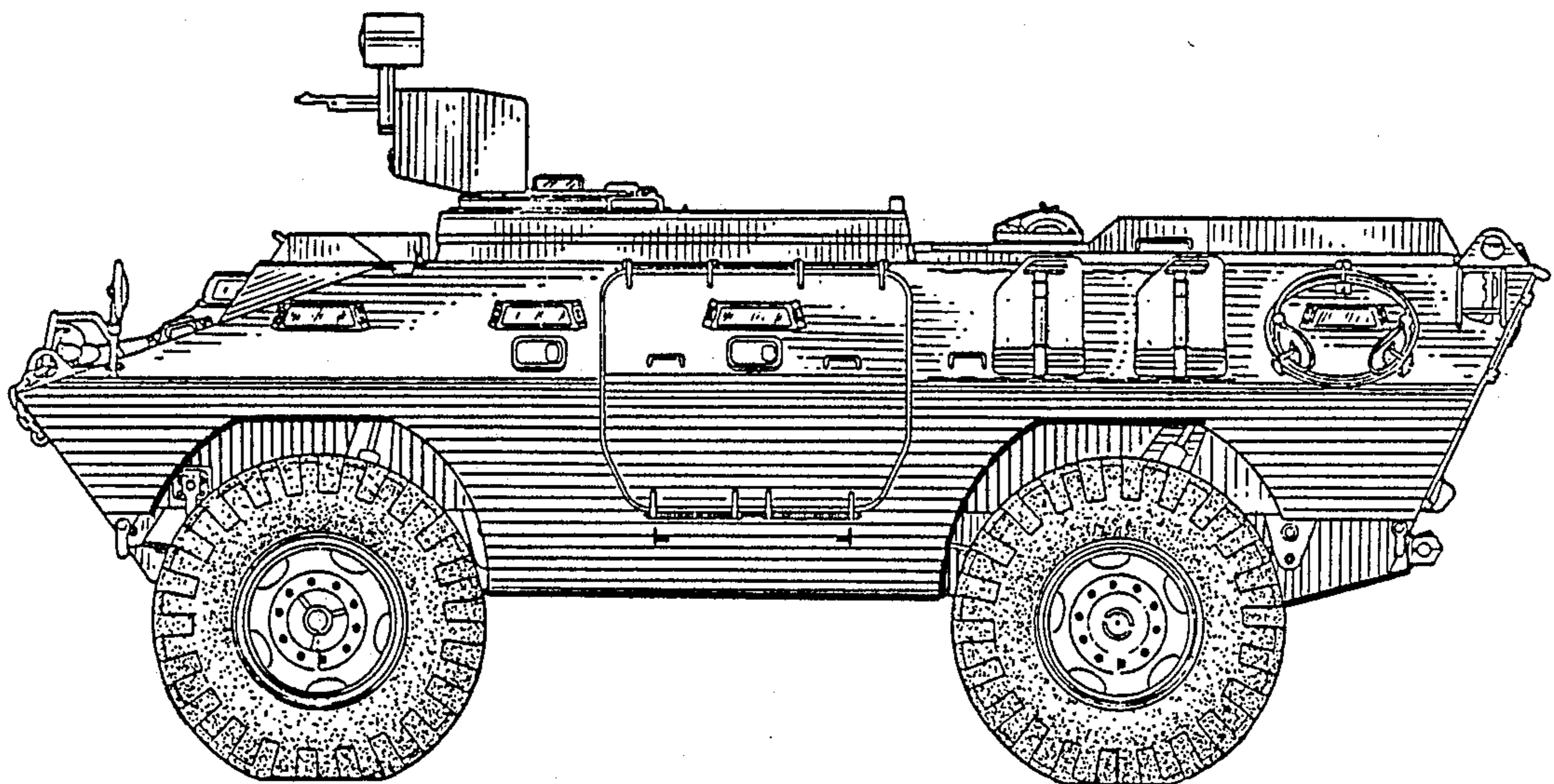


FIG. 11.

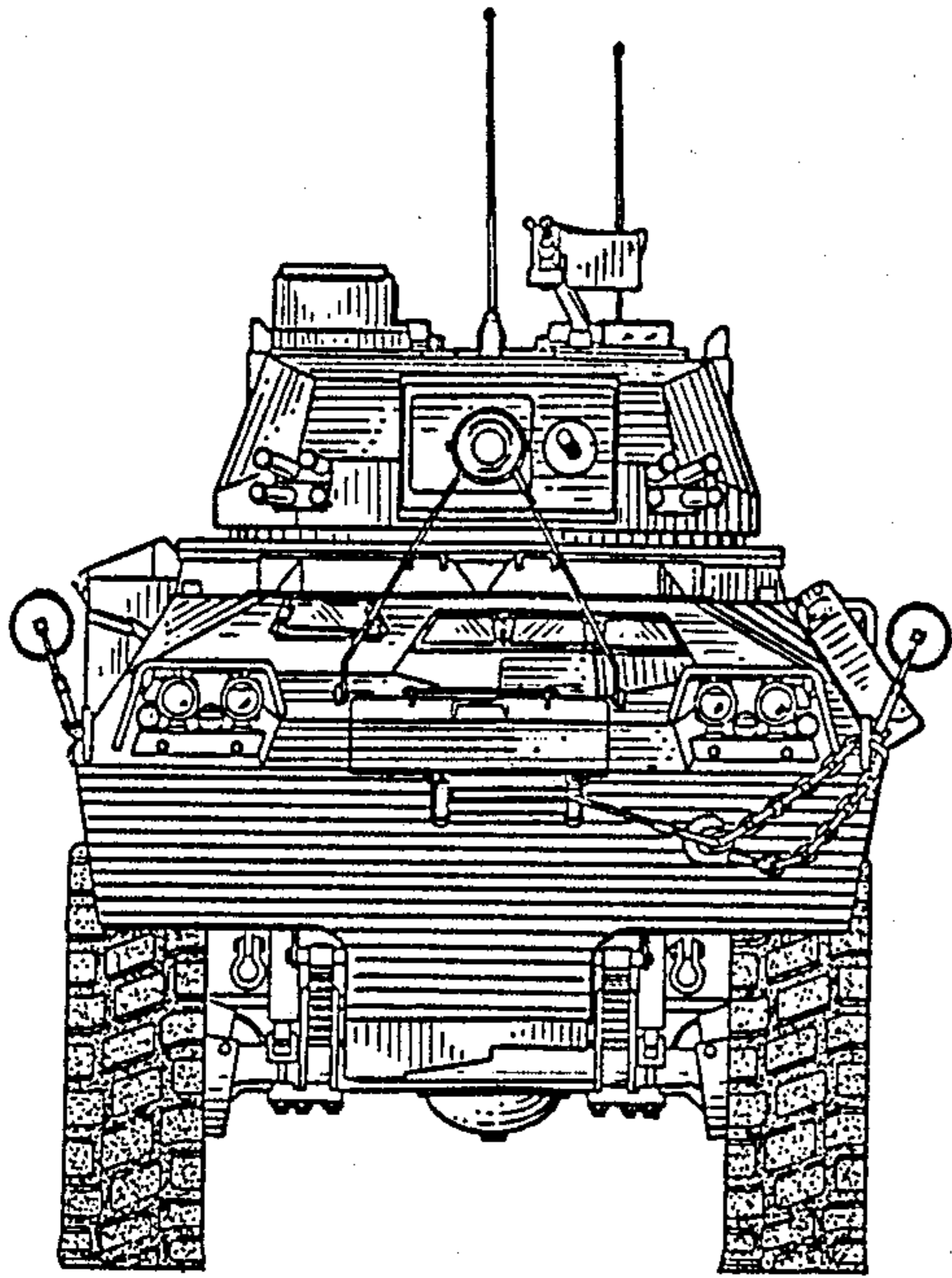


FIG. 12.

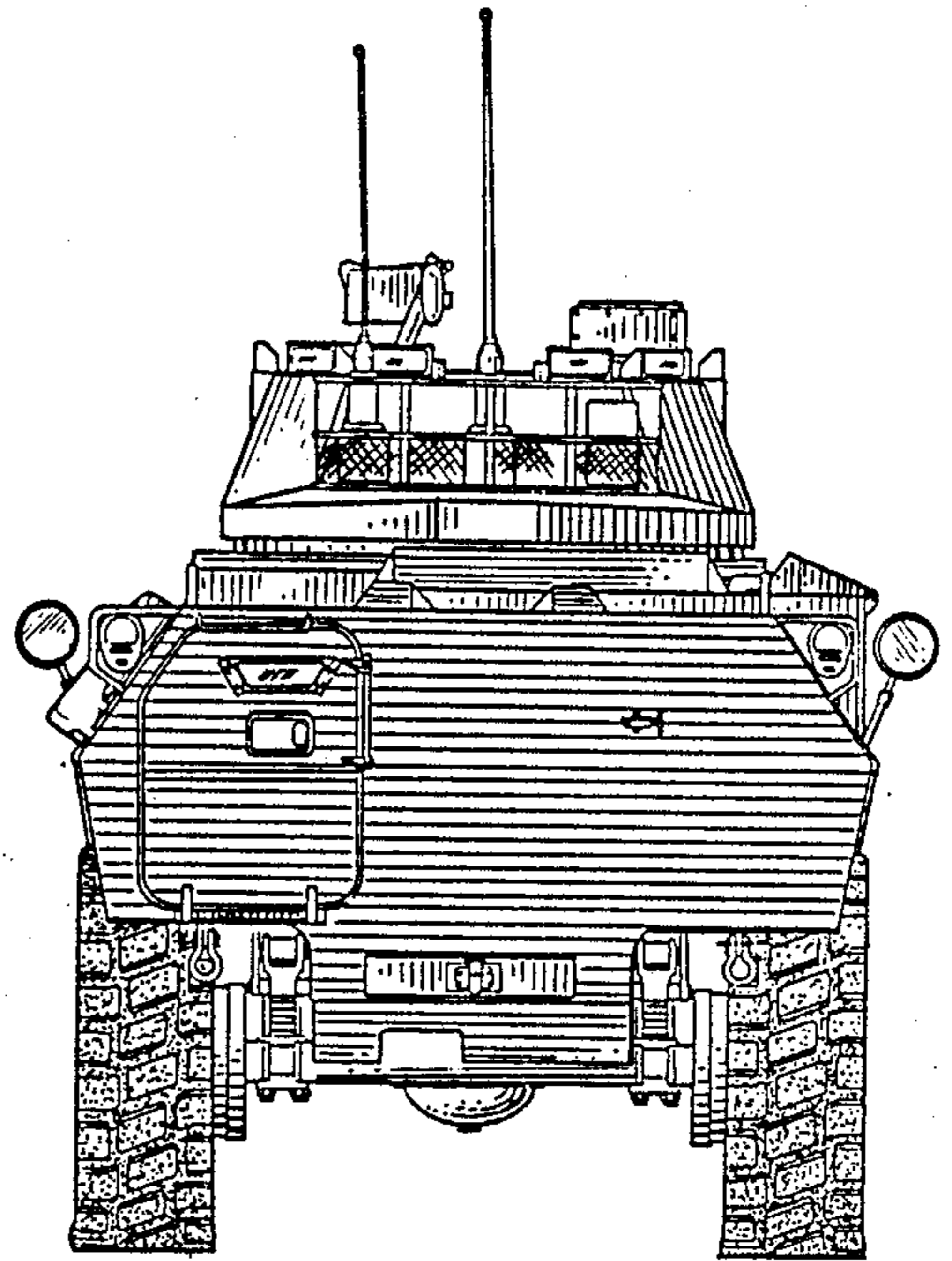
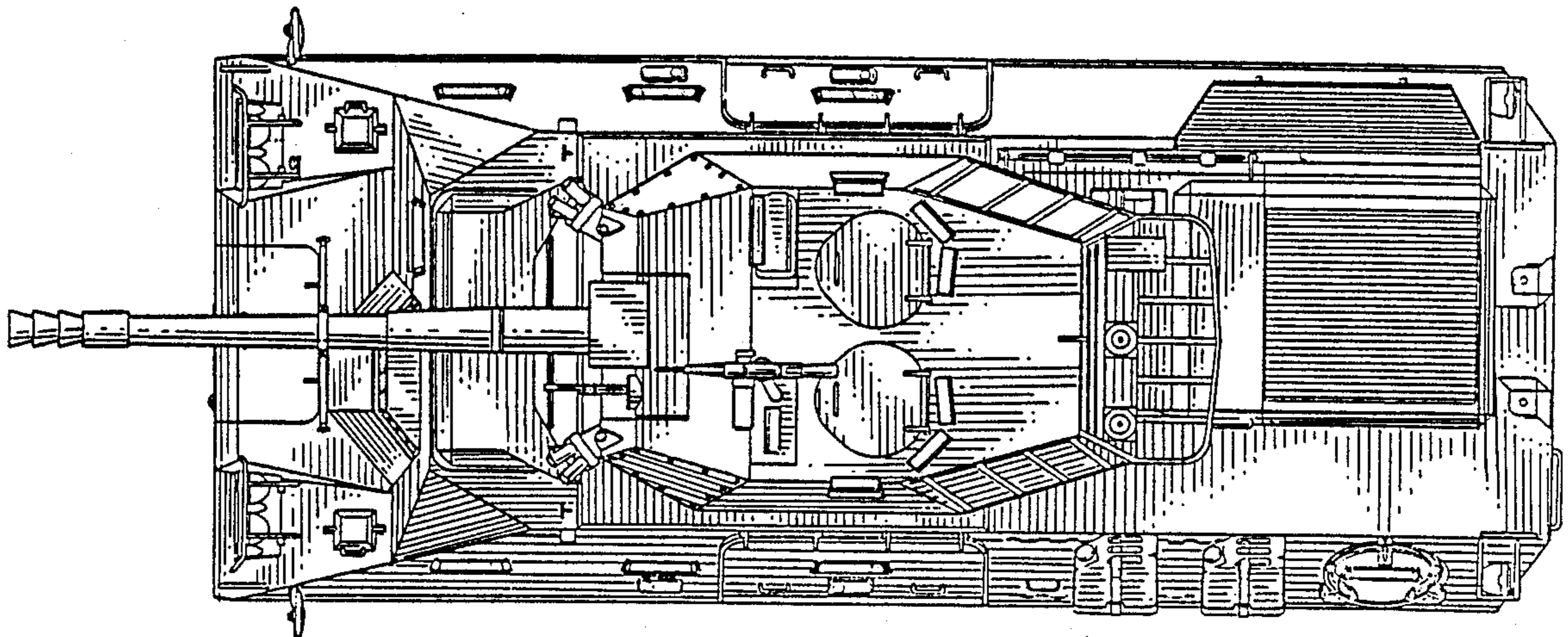
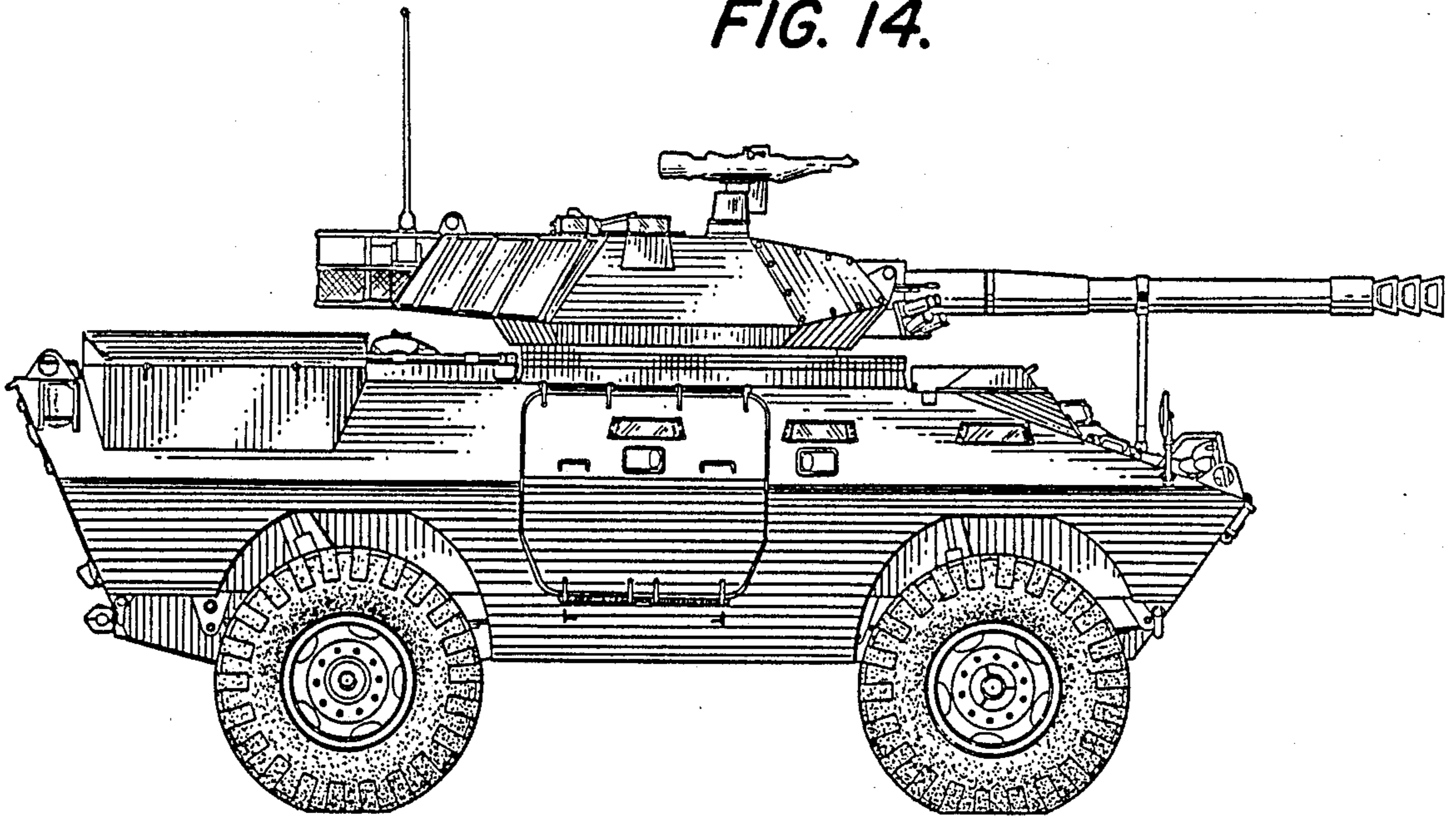


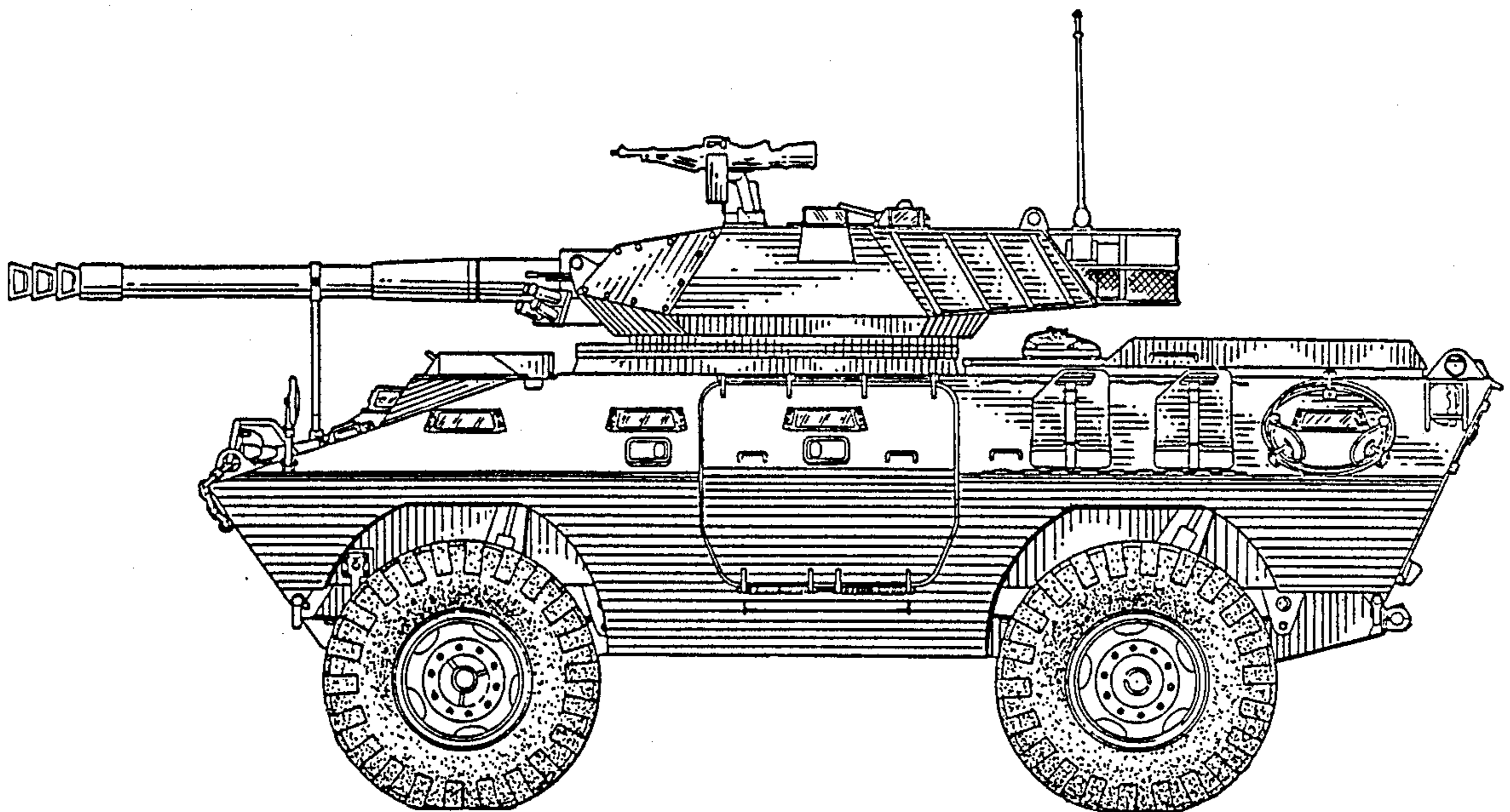
FIG. 13.



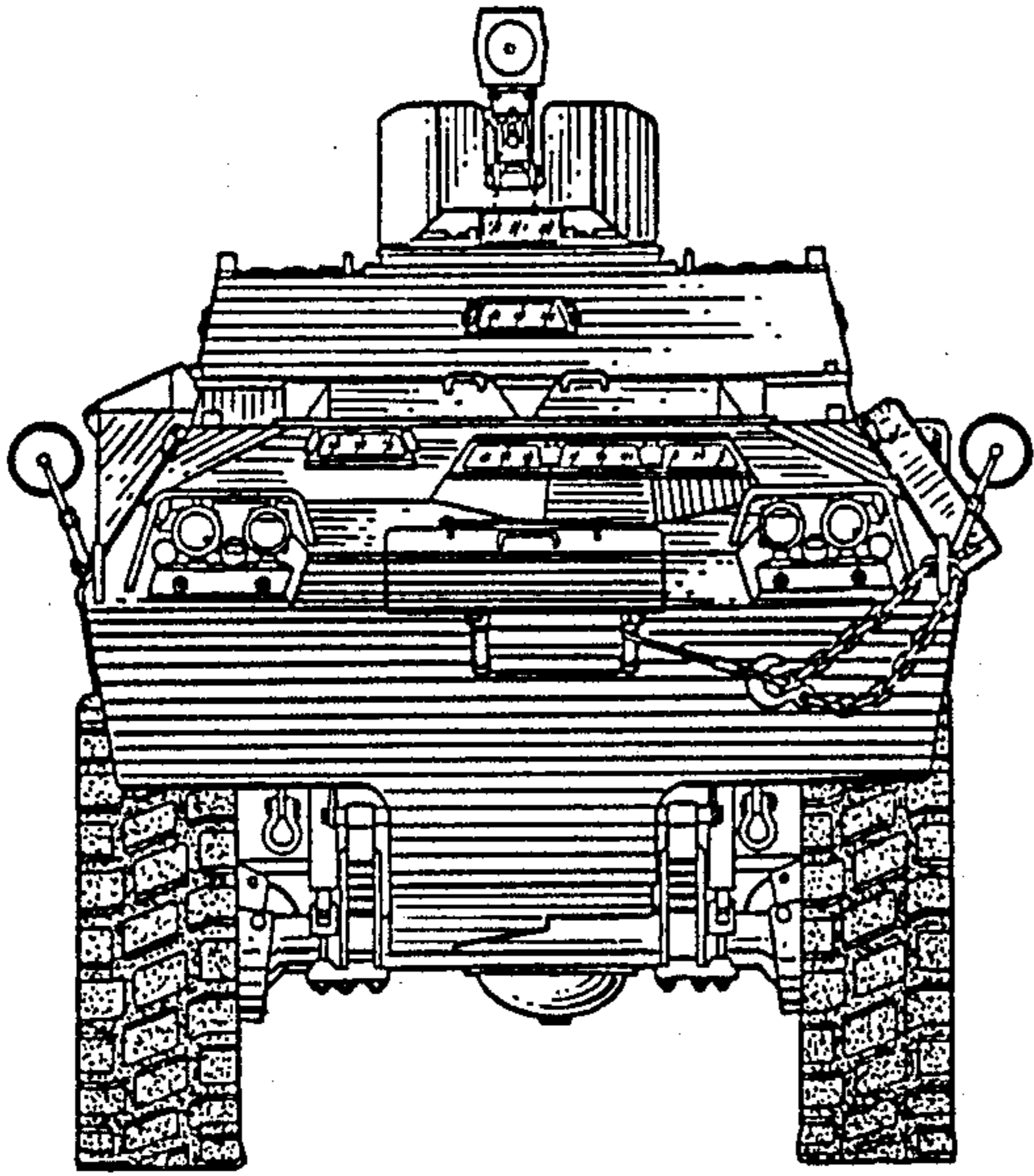
*FIG. 14.*



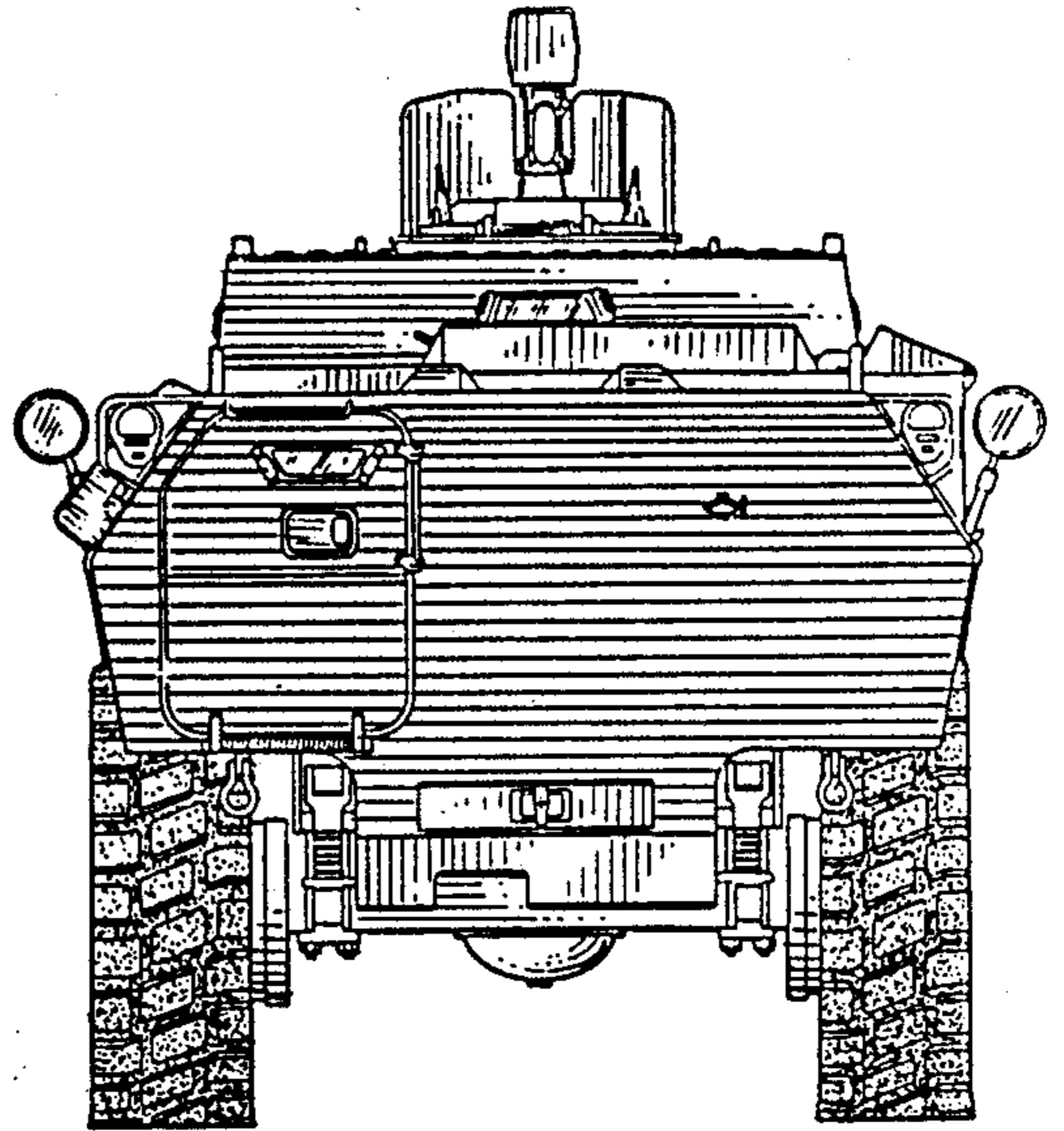
*FIG. 15.*



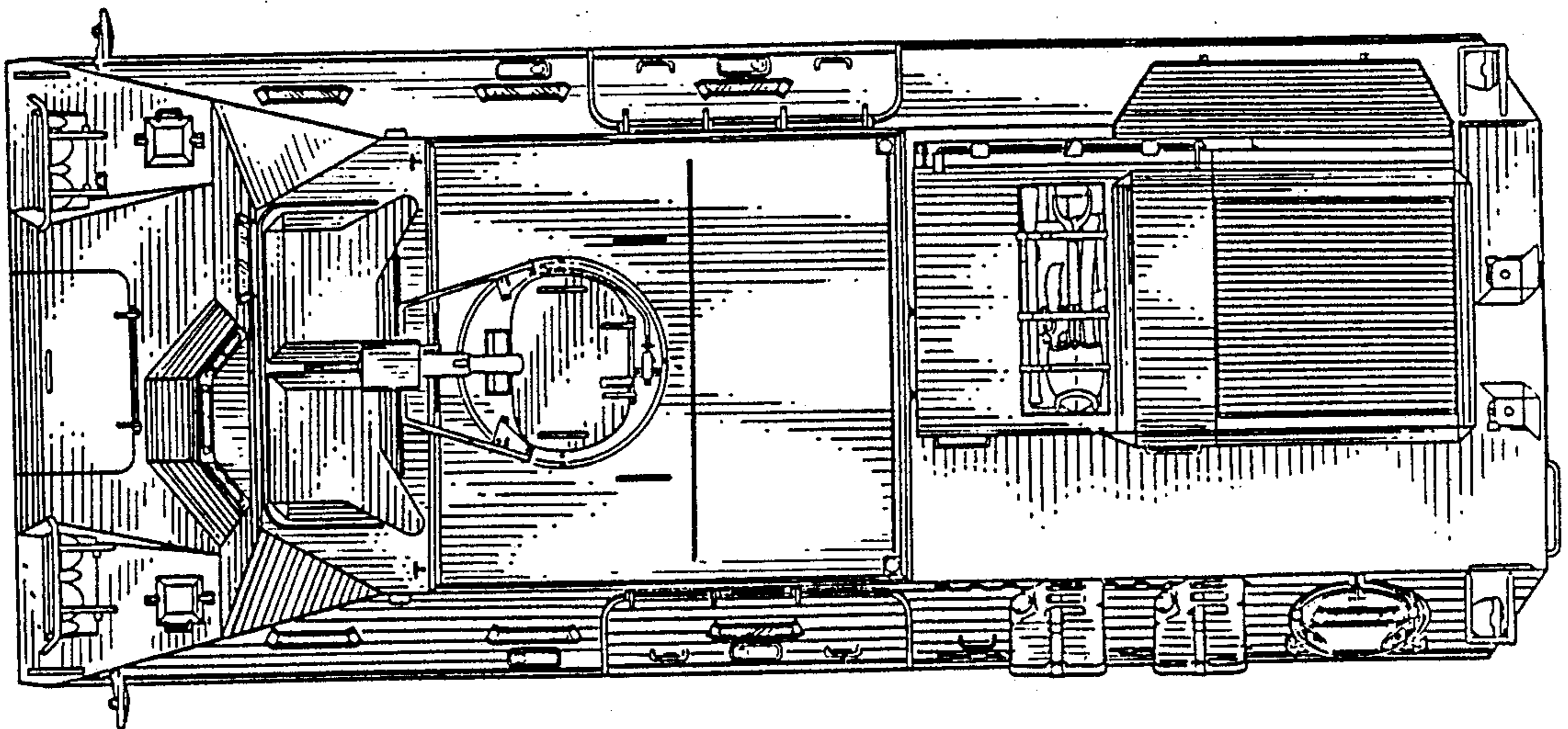
*FIG. 16.*



*FIG. 17.*

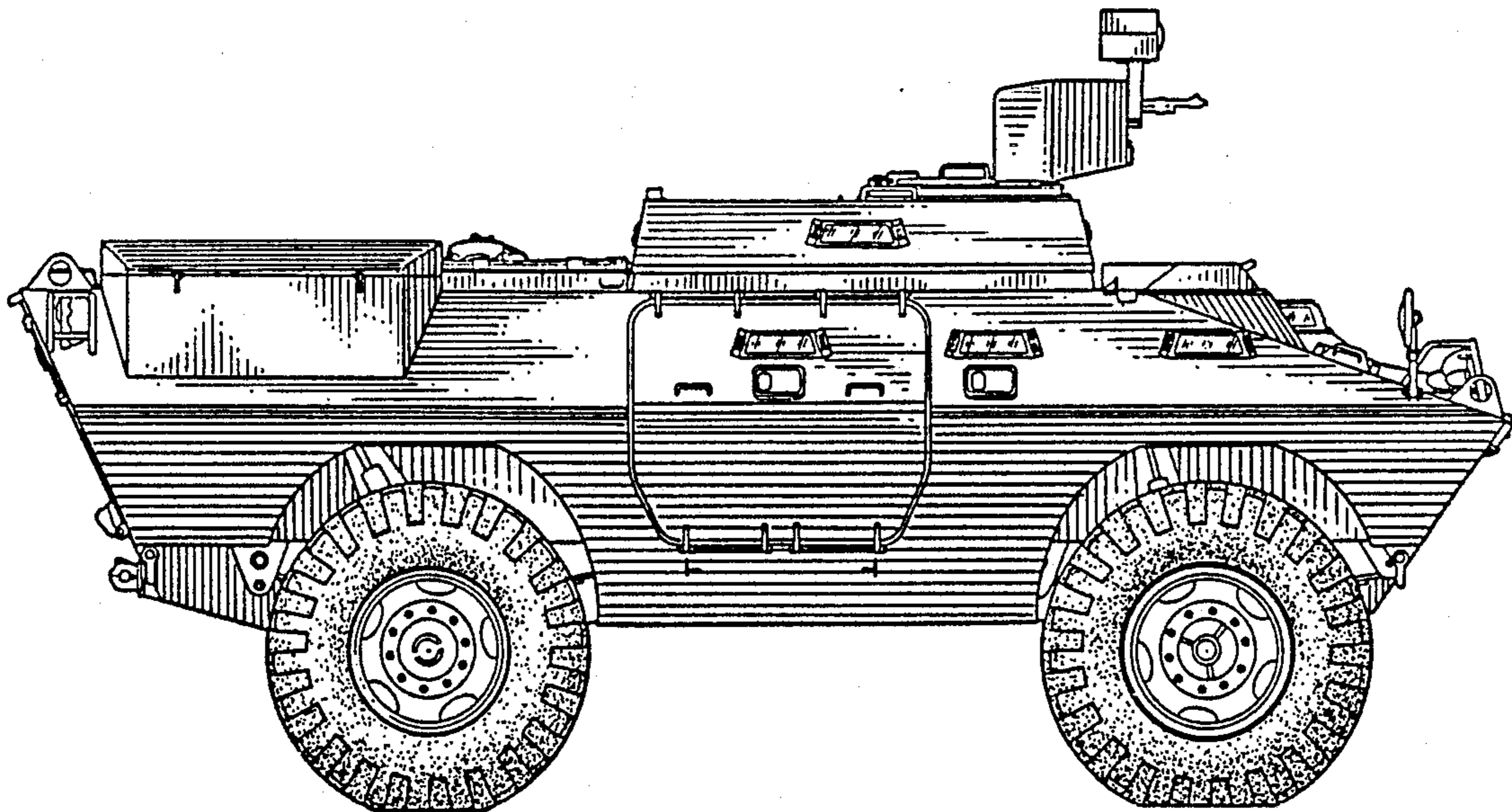


*FIG. 18.*

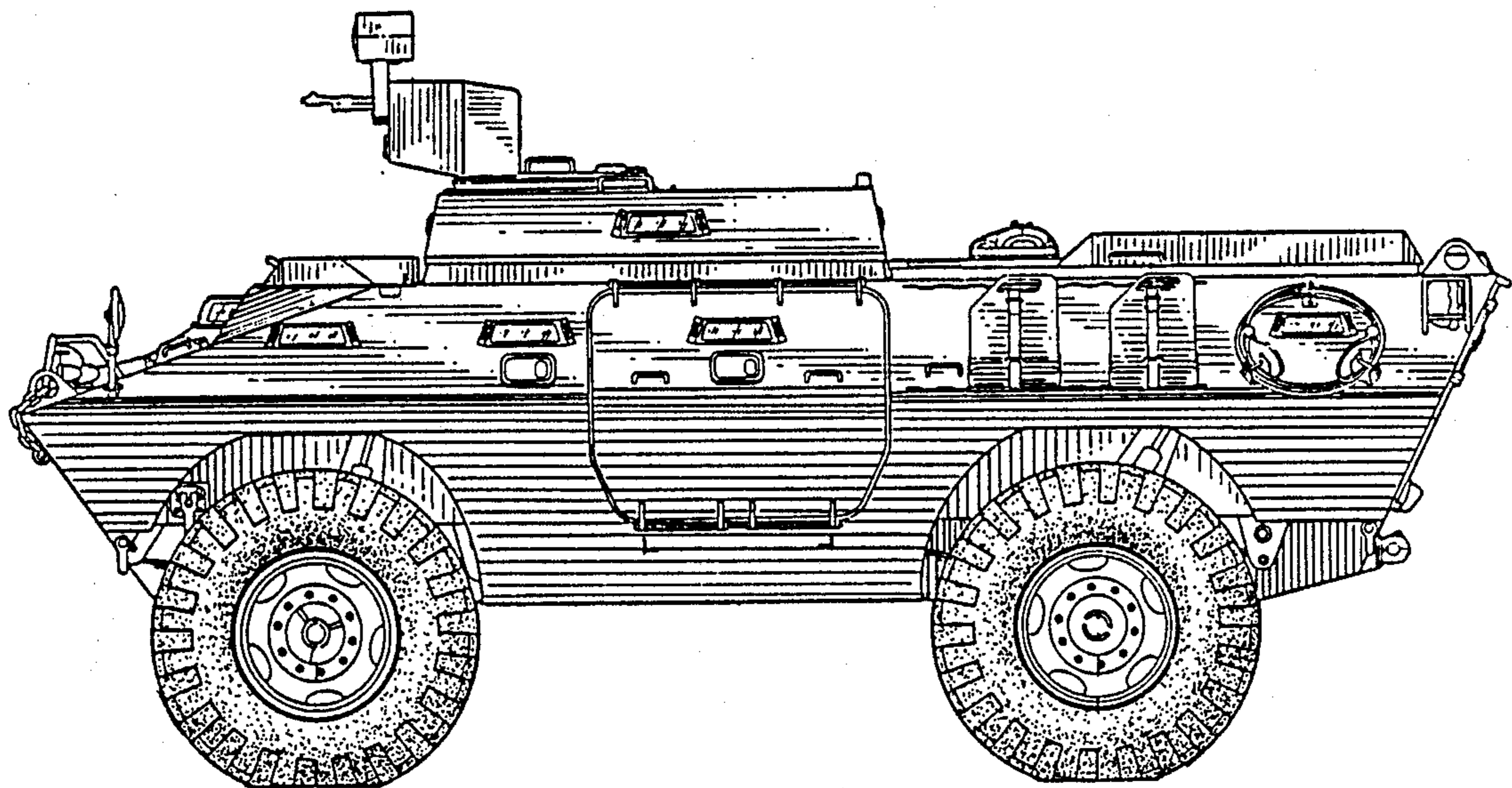




*FIG. 19.*



*FIG. 20.*



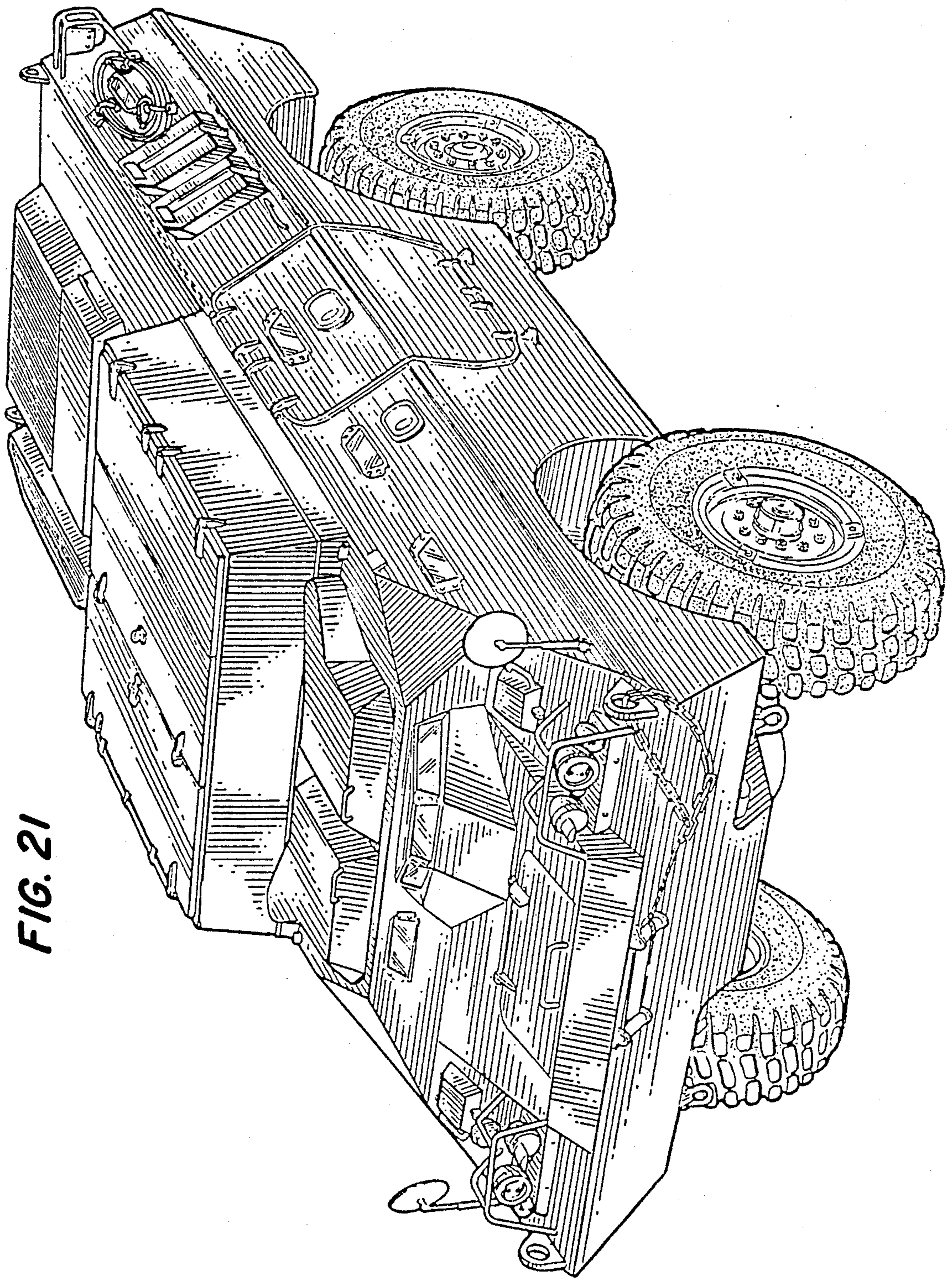
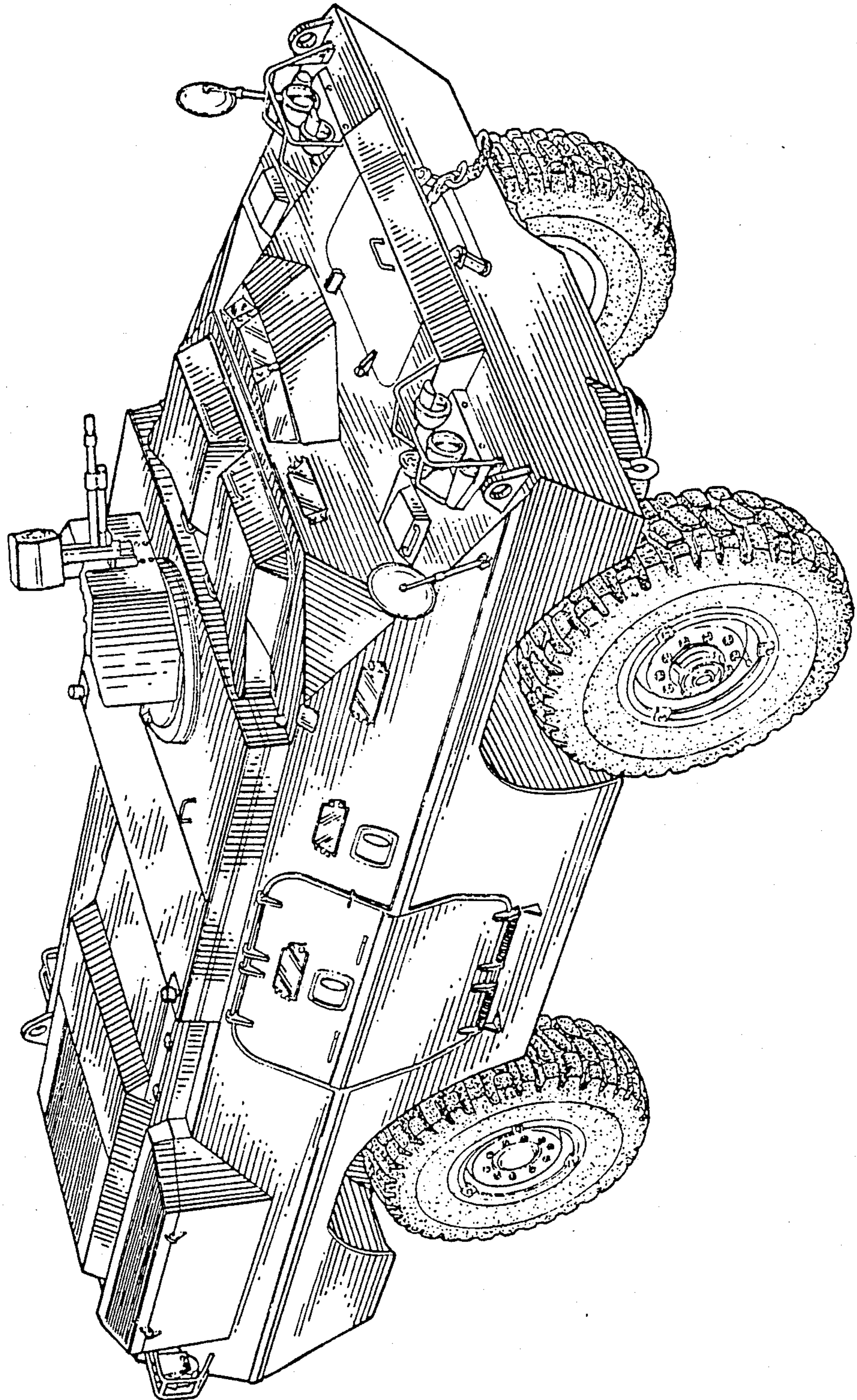


FIG. 21

FIG. 22



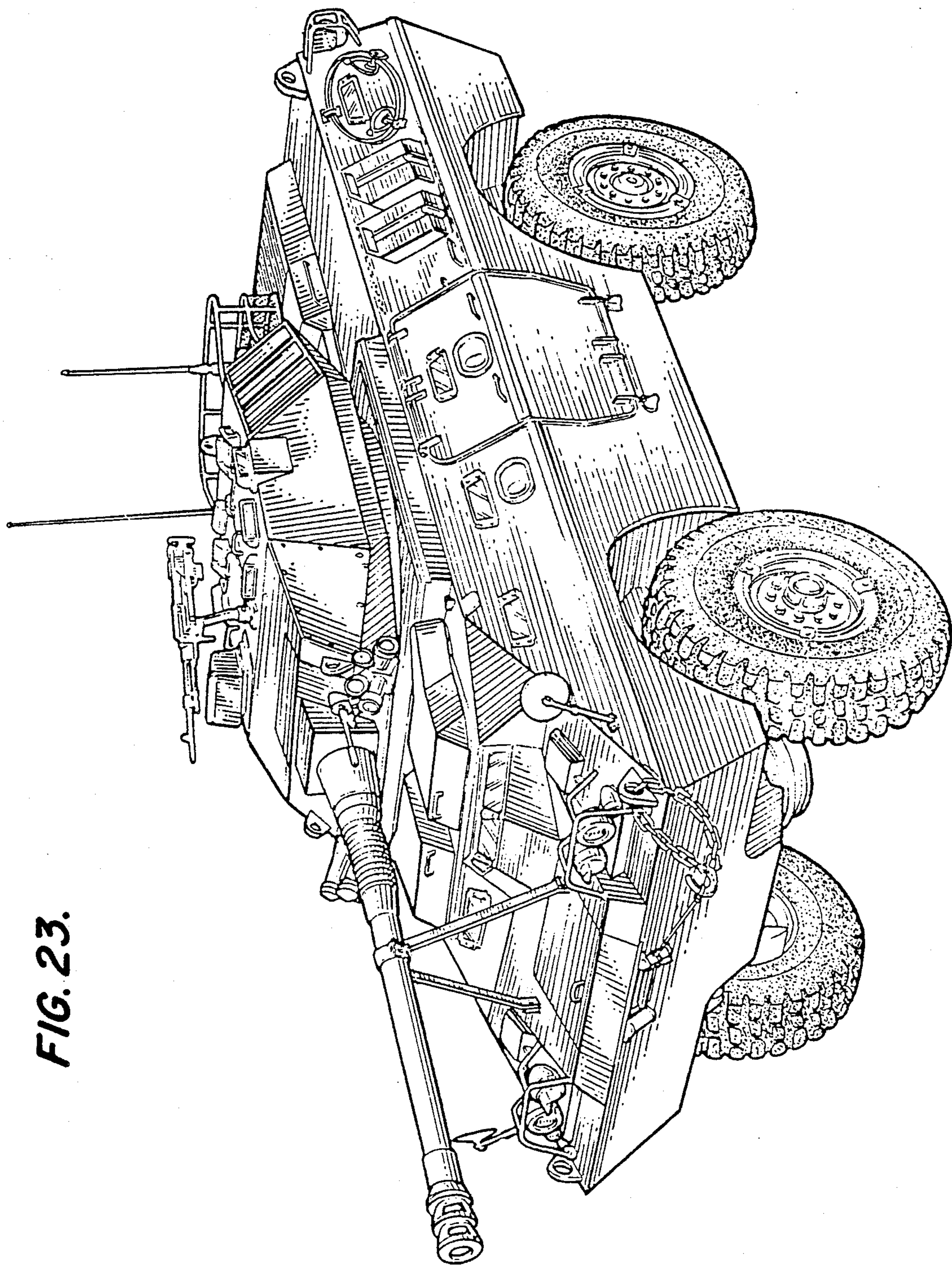


FIG. 23.

FIG. 24.

