

[54] **AIRCRAFT**
[76] **Inventor: Gerald L. Butler, P.O. Box 150163, Arlington, Tex. 76015**
[**] **Term: 14 Years**
[21] **Appl. No.: 93,902**
[22] **Filed: Sep. 8, 1987**
[52] **U.S. Cl. D12/342; D12/331**
[58] **Field of Search D12/319, 331, 342; 244/45 R, 36; D21/87, 89**

[56] **References Cited**
U.S. PATENT DOCUMENTS
D. 292,910 11/1987 McGiboney D12/342
4,090,681 5/1978 Zimmer 244/45 R
4,146,199 3/1979 Wenzel 244/36
FOREIGN PATENT DOCUMENTS
3636046 4/1988 Fed. Rep. of Germany 244/36

Primary Examiner—Wallace R. Burke
Assistant Examiner—Kay H. Chin
Attorney, Agent, or Firm—Kenneth A. Roddy

[57] **CLAIM**
The ornamental design for an aircraft, as shown and described.

DESCRIPTION
FIG. 1 is a top plan view of an aircraft showing my new design;
FIG. 2 is a side elevational view thereof, the opposite side view being a mirror image of that shown;
FIG. 3 is a front elevational view thereof;
FIG. 4 is a bottom plan view thereof;
FIG. 5 is a rear elevational view thereof;
FIG. 6 is a top perspective view thereof;
FIG. 7 is a bottom perspective view thereof; and
FIG. 8 is a bottom plan view of a second embodiment of the aircraft. The top, side, and rear views of the second embodiment are identical to FIGS. 1, 2, 3, 5, and 6.

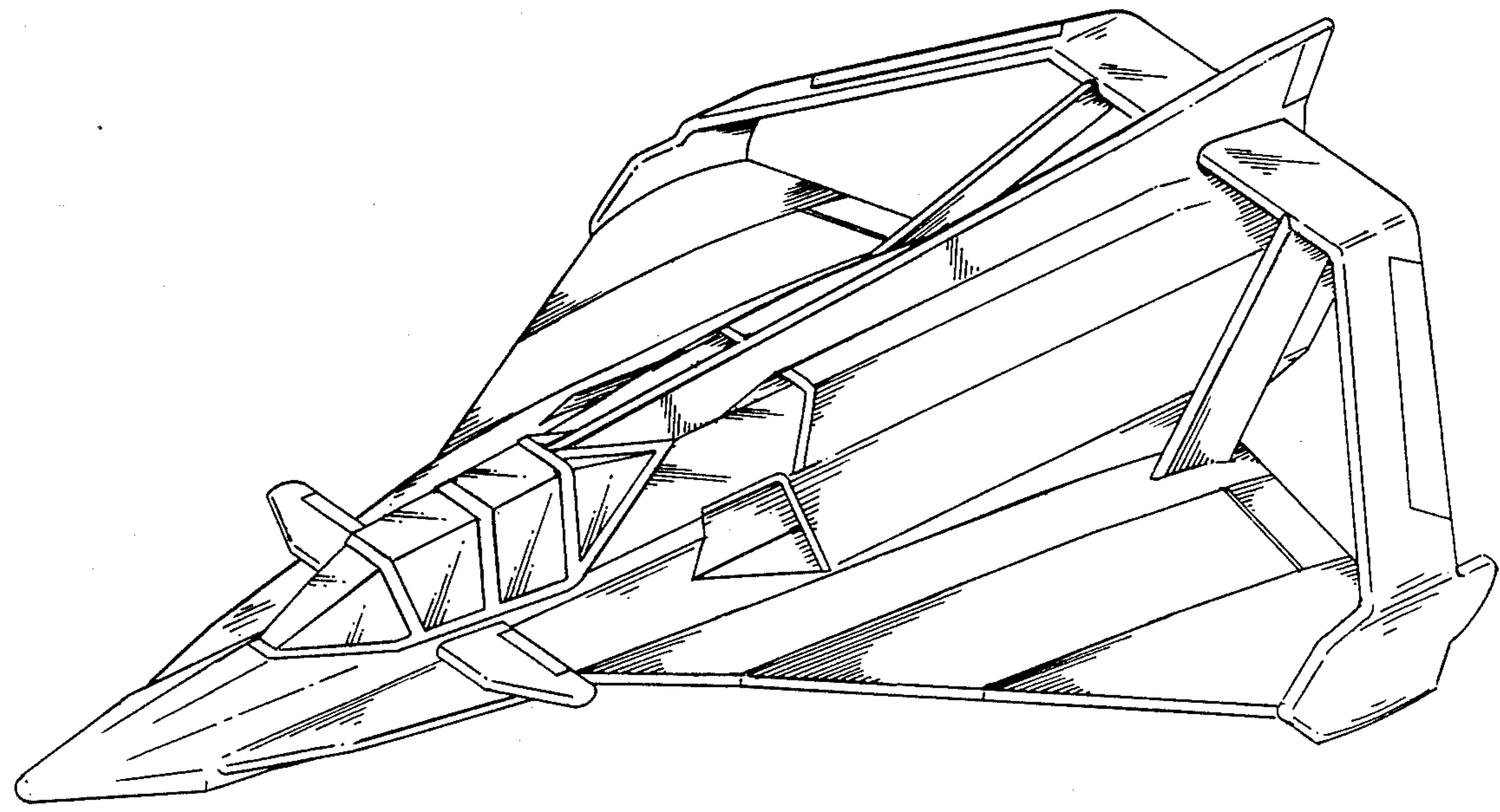

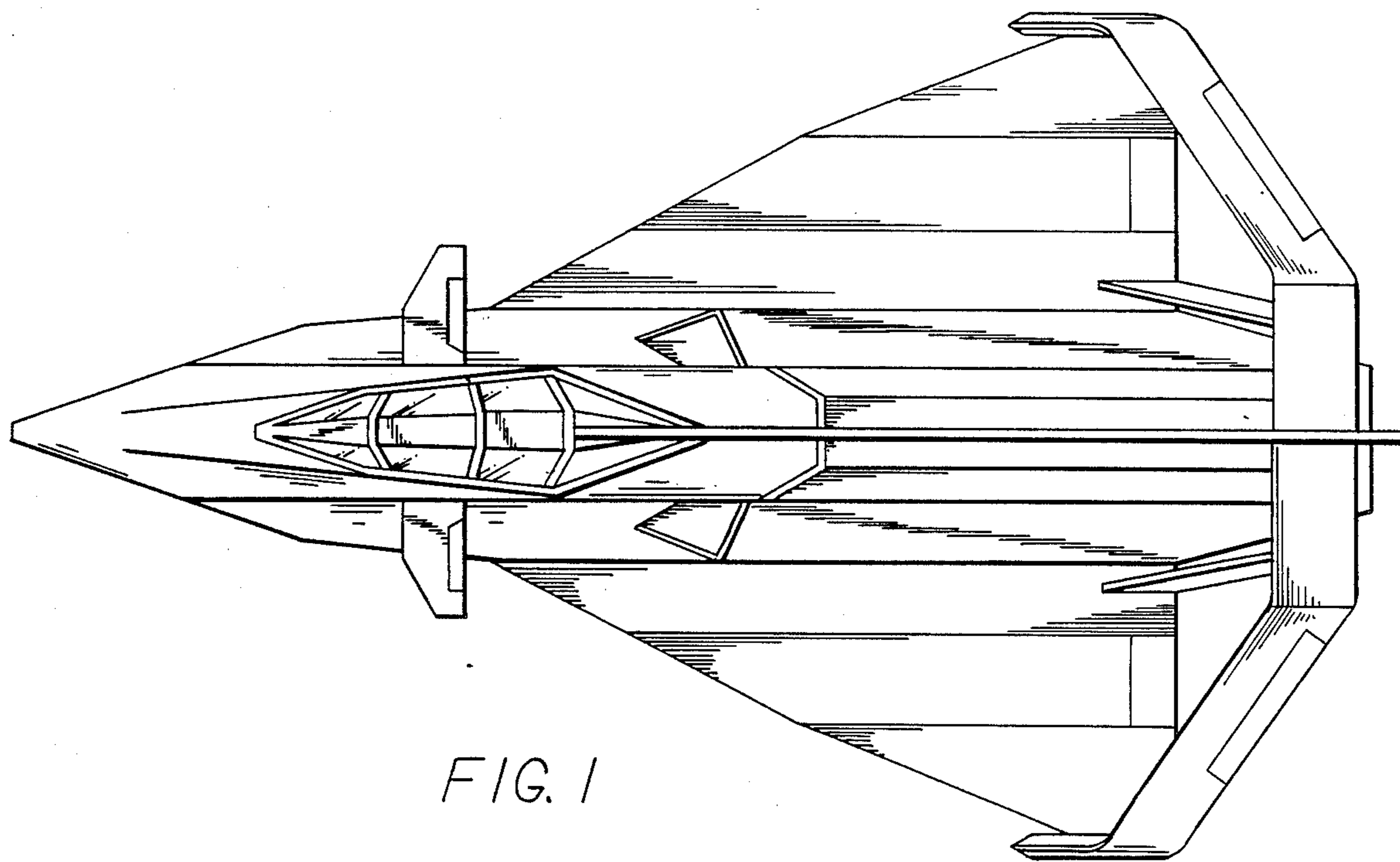

FIG. 1

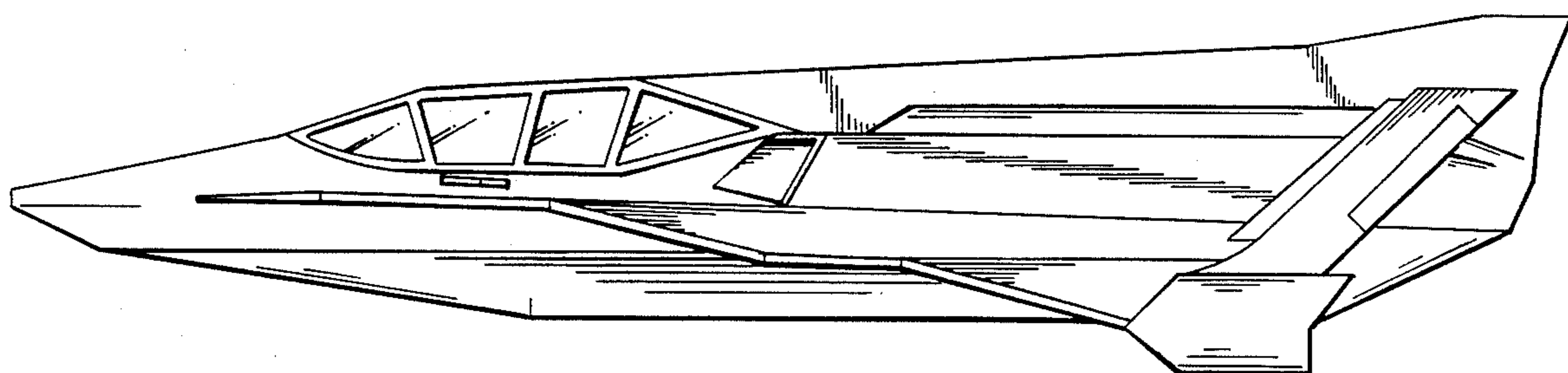

FIG. 2

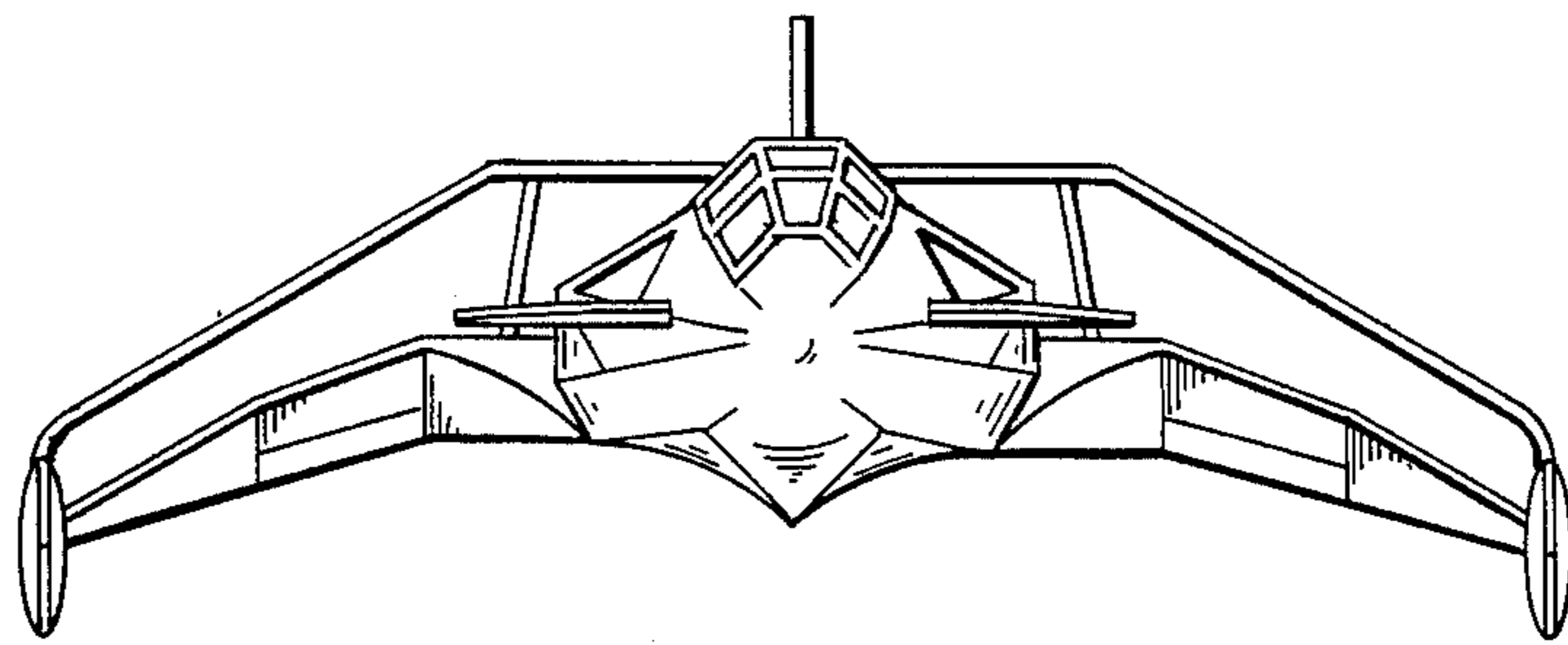

FIG. 3

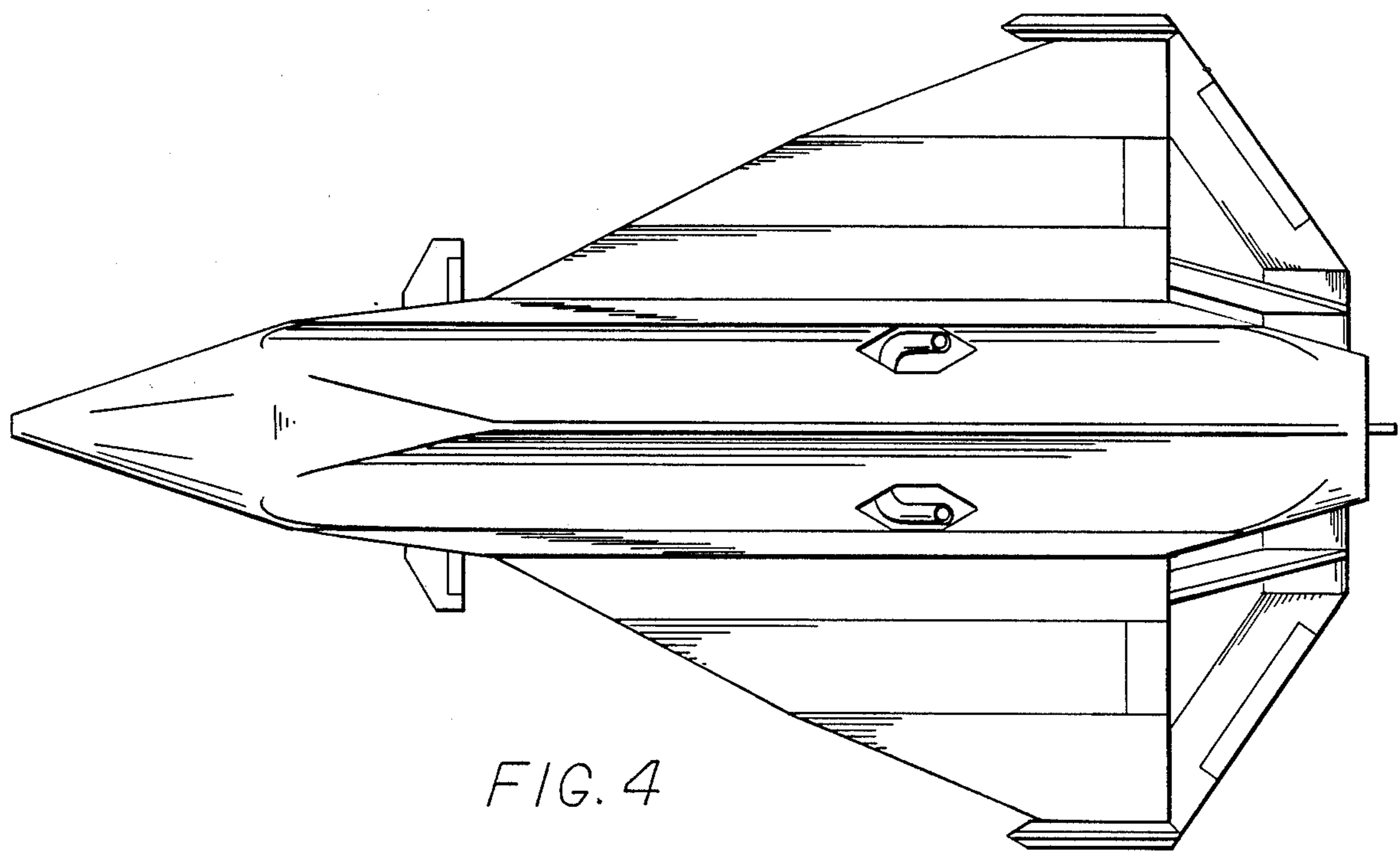

FIG. 4

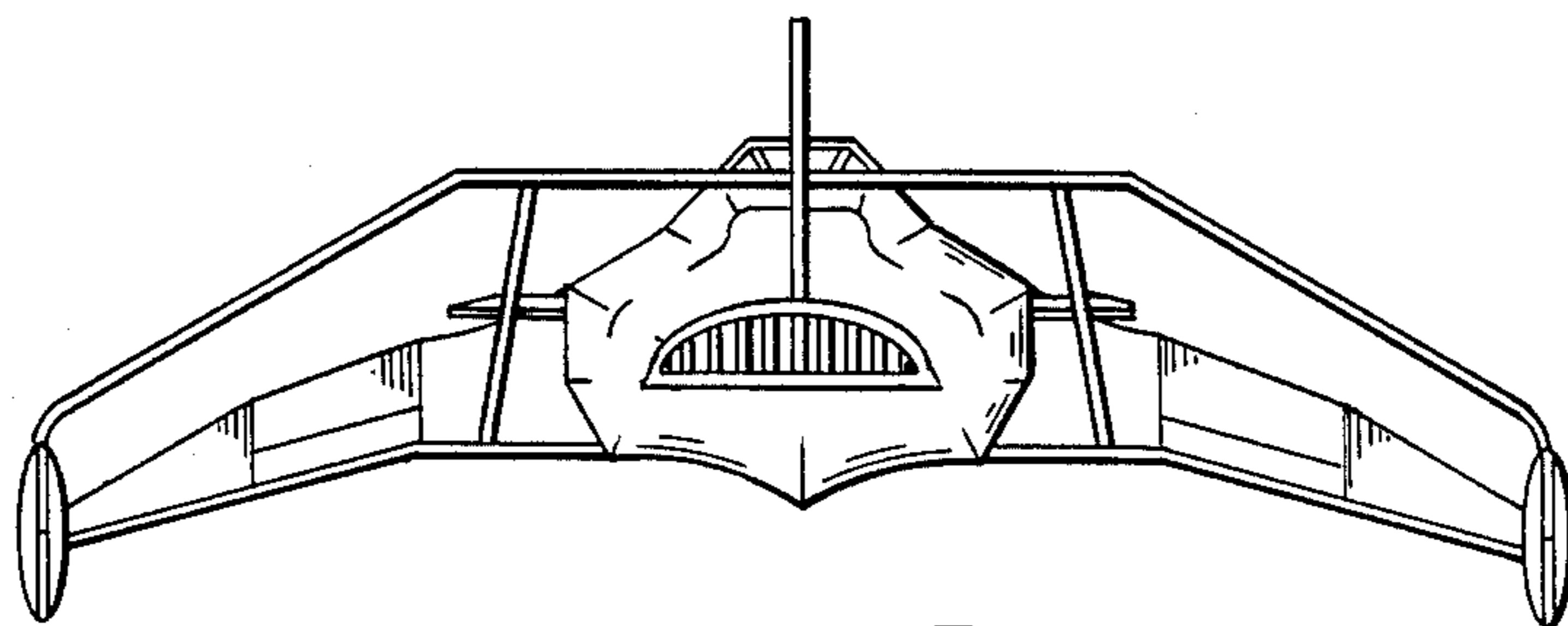

FIG. 5

FIG. 6

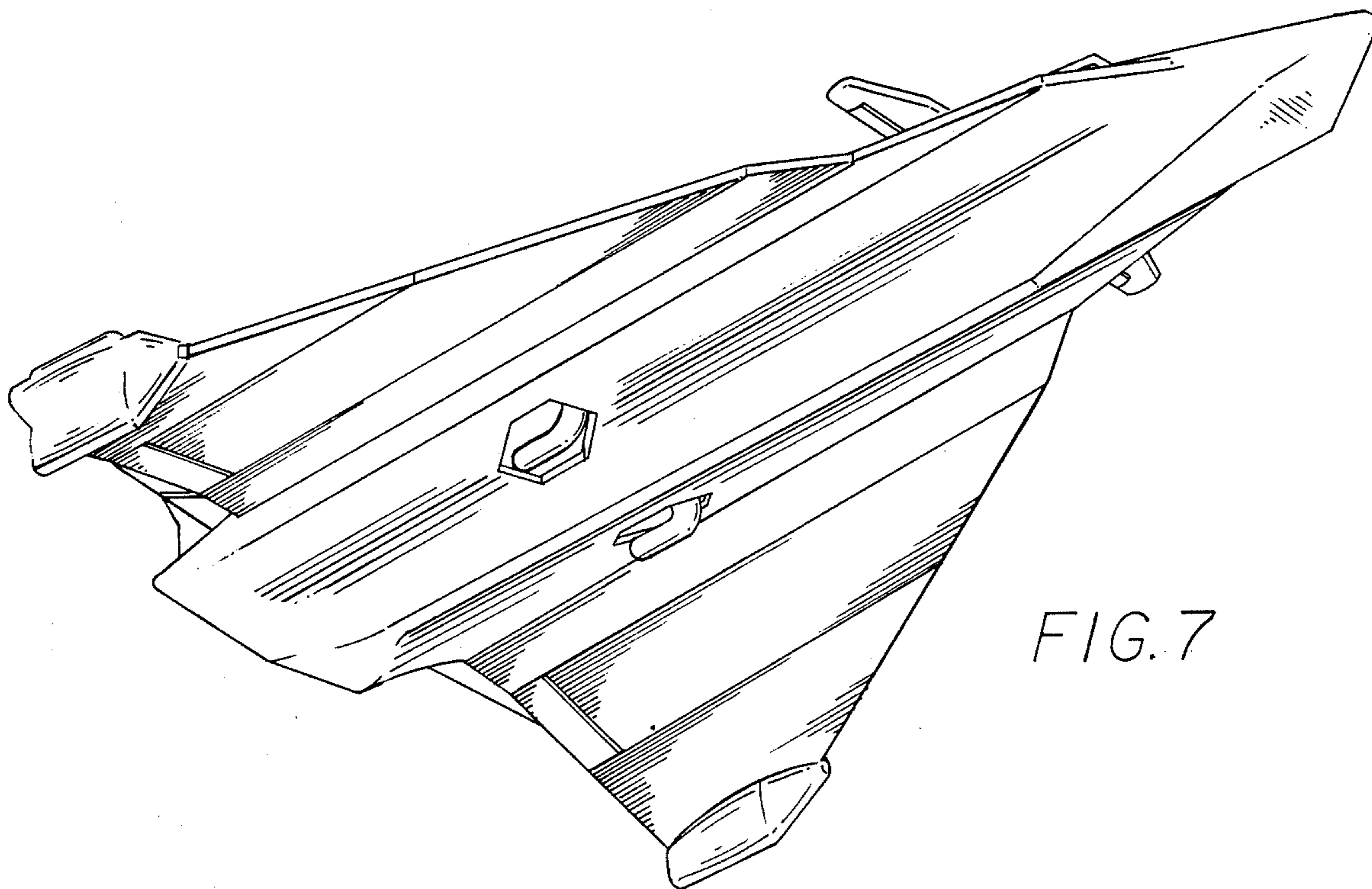
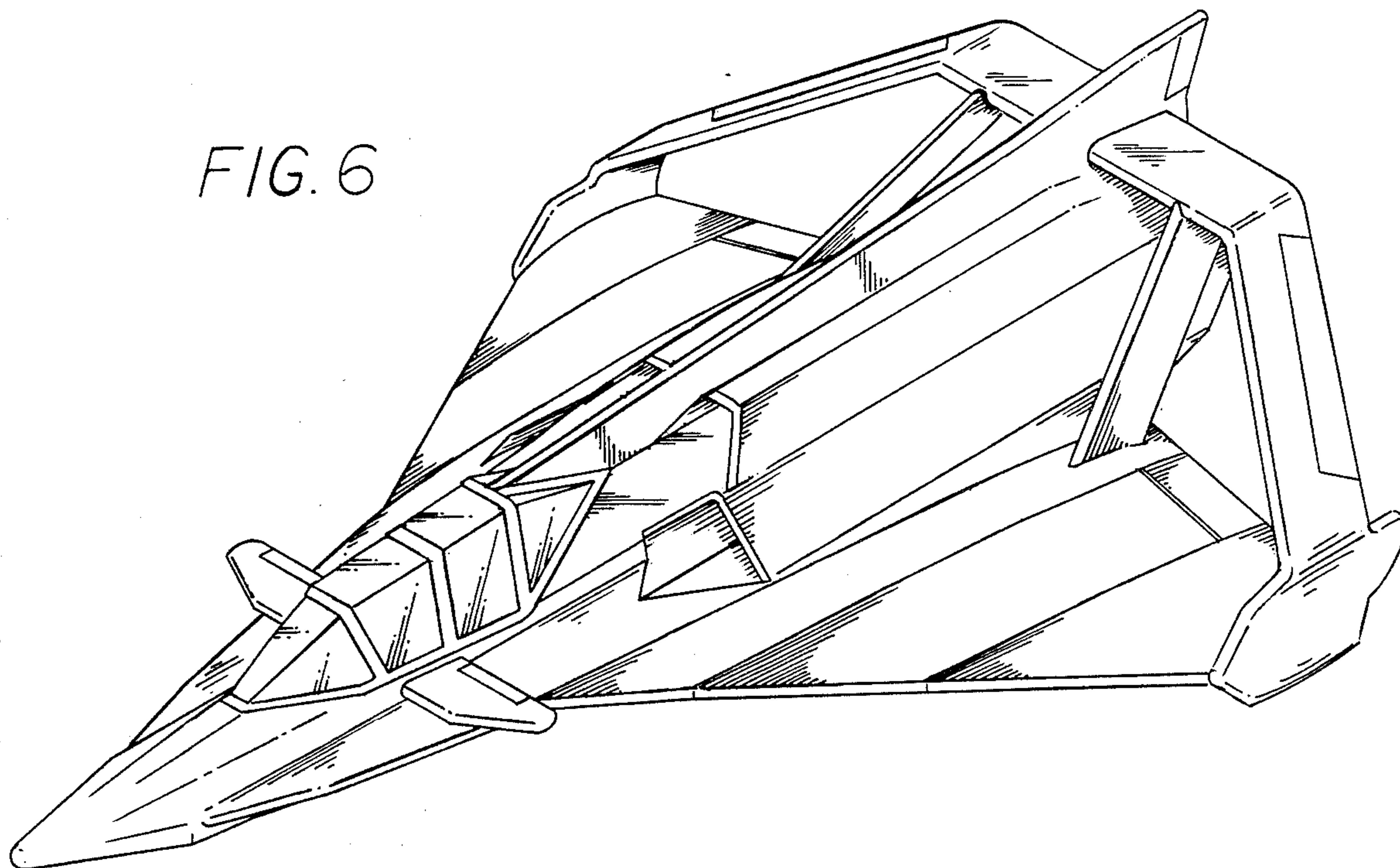

FIG. 7

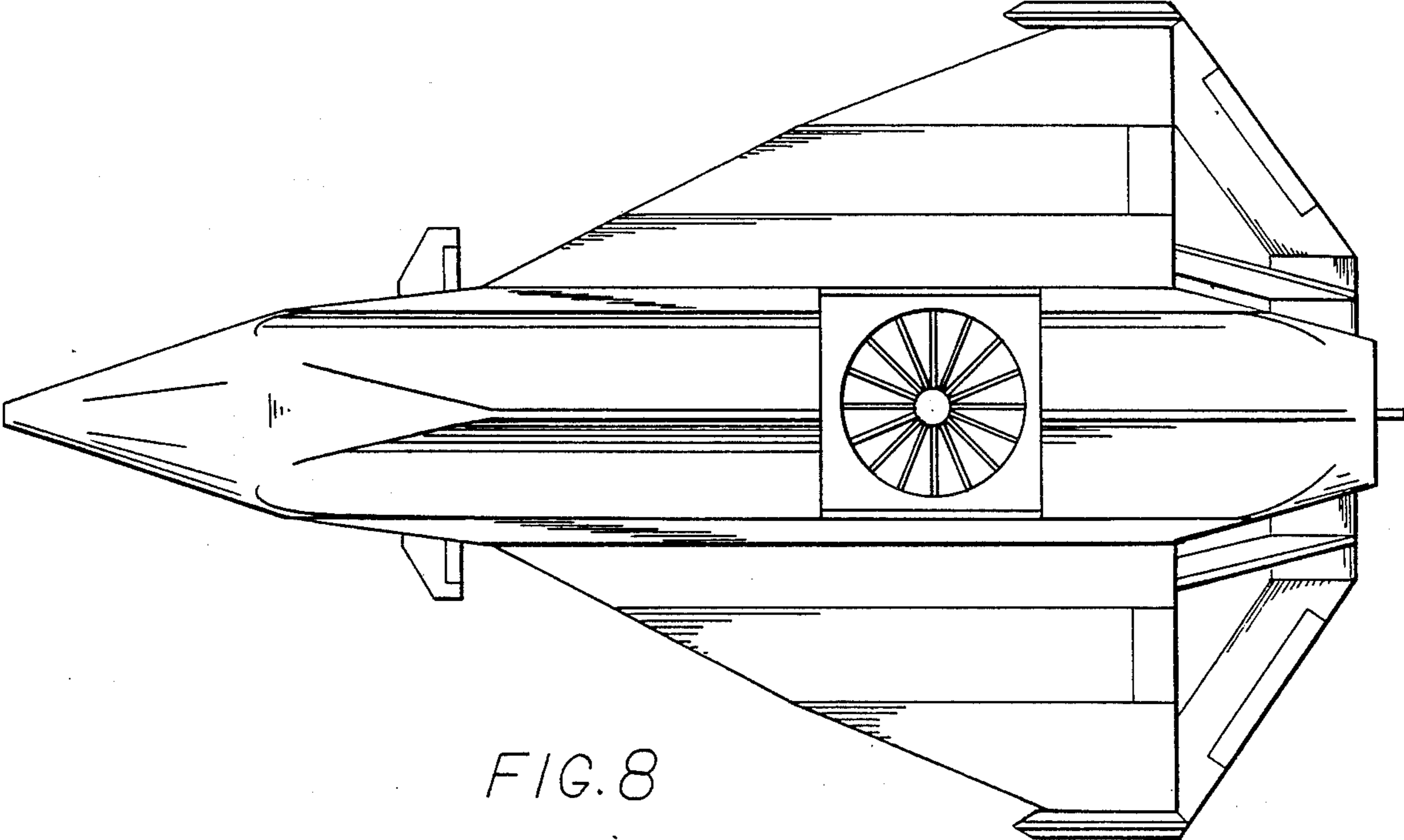

FIG. 8