

[54] **COMBINED VEHICLE BUMPER AND GUARD**

[76] **Inventor: Keith R. Aiken, P.O. Box 276, Campbelltown, New South Wales, Australia**

[**] **Term: 14 Years**

[21] **Appl. No.: 70,519**

[22] **Filed: Jul. 7, 1987**

[30] **Foreign Application Priority Data**

Feb. 3, 1987 [AU] Australia 0322/87
[52] **U.S. Cl.** **D12/169; D12/171**
[58] **Field of Search** **D12/169, 171, 167; 293/102, 112, 115, 143, 146**

[56] **References Cited**

U.S. PATENT DOCUMENTS

D. 148,980 3/1948 Bustin D12/171
D. 248,229 6/1978 Baker D12/169
D. 258,502 3/1981 Nespor D12/169
D. 300,128 3/1989 Brennan D12/169

Primary Examiner—James M. Gandy
Attorney, Agent, or Firm—Dressler, Goldsmith, Shore, Sutker & Milnamow, Ltd.

[57] **CLAIM**

The ornamental design for a combined vehicle bumper and guard, as shown and described.

DESCRIPTION

FIG. 1 is a perspective view of a combined vehicle bumper and guard showing my new design; FIG. 2 is a rear elevation view thereof; and FIG. 3 is a side elevation view thereof, the opposite side being a mirror image of that shown.

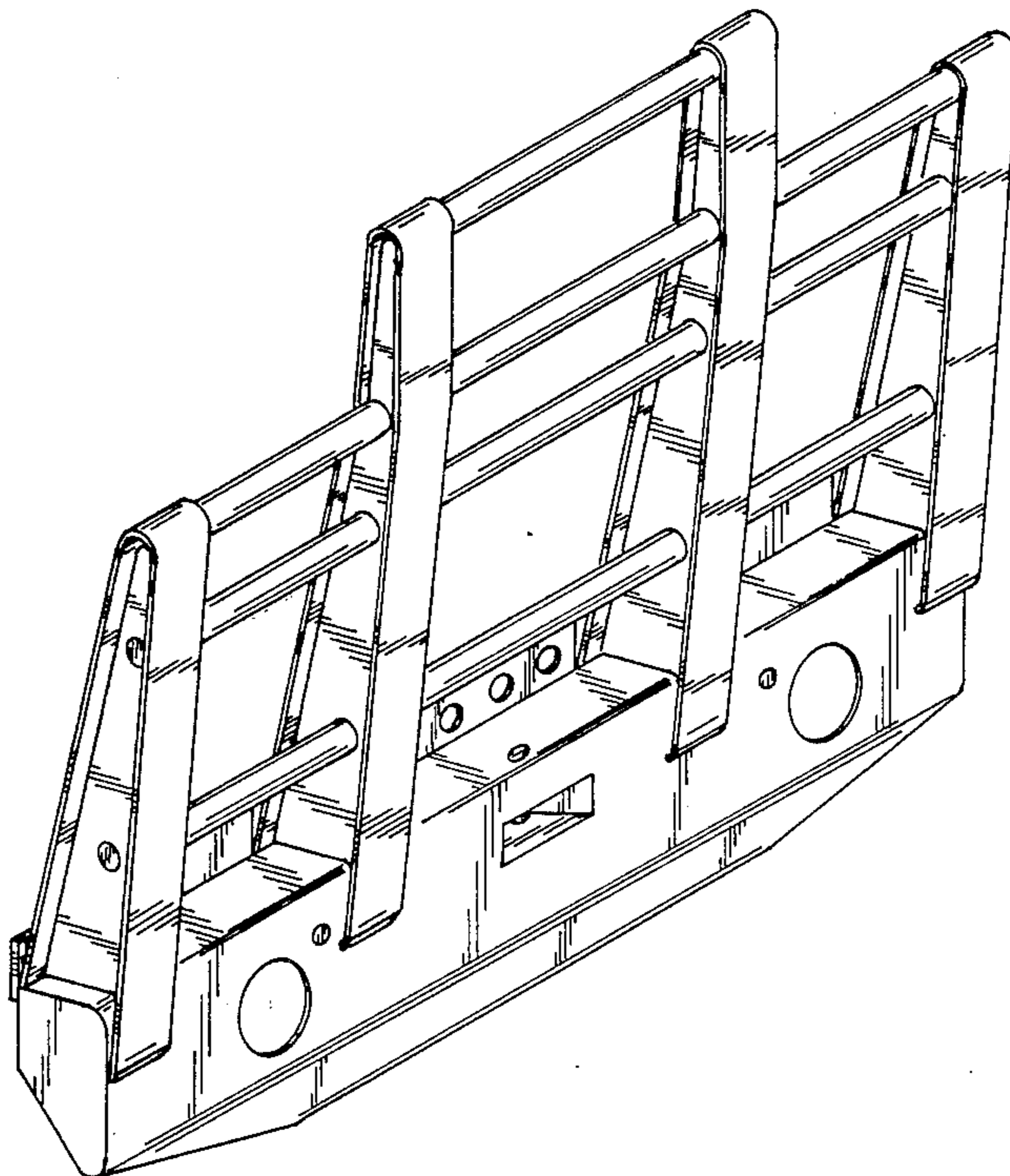

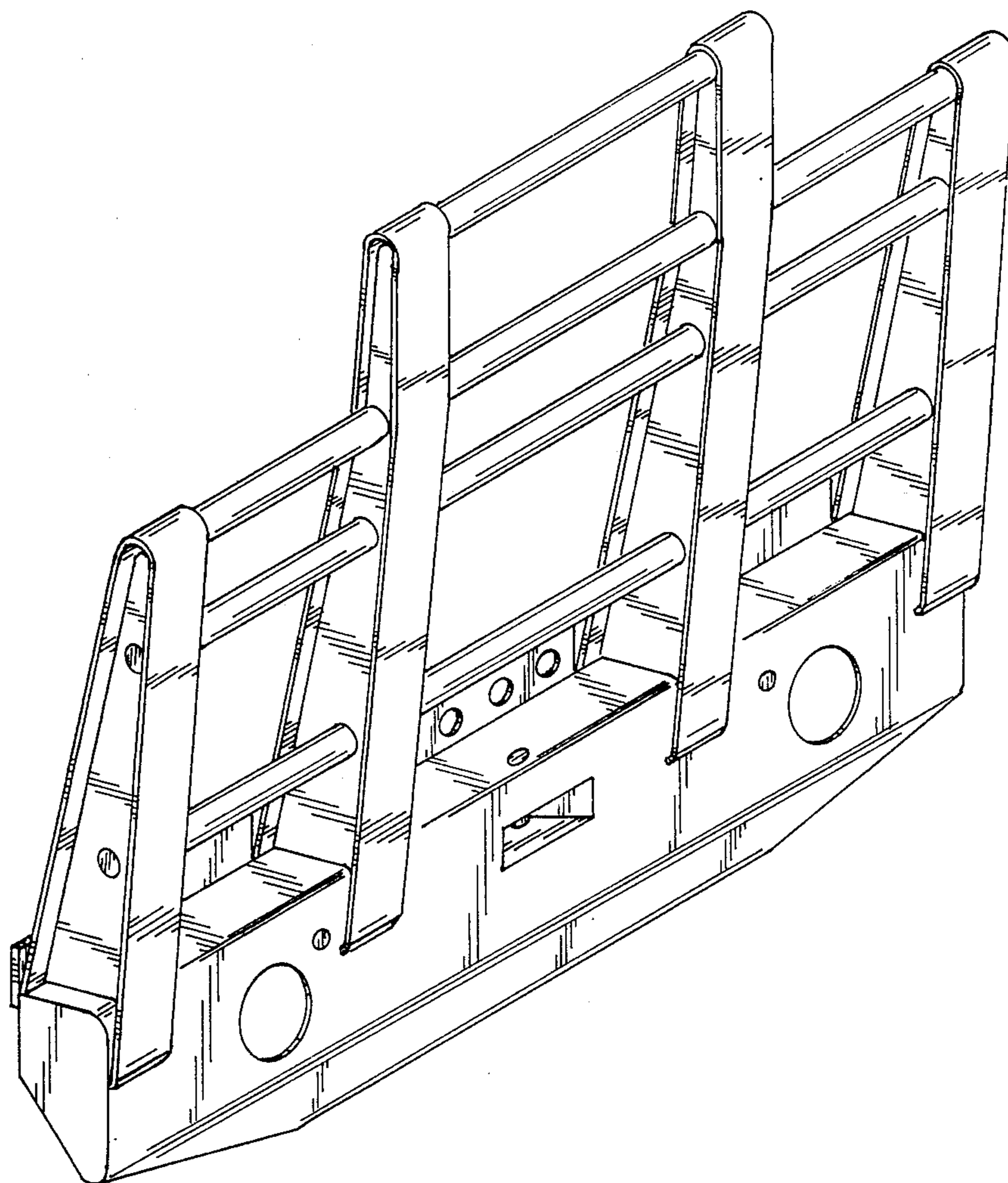

FIGURE 1

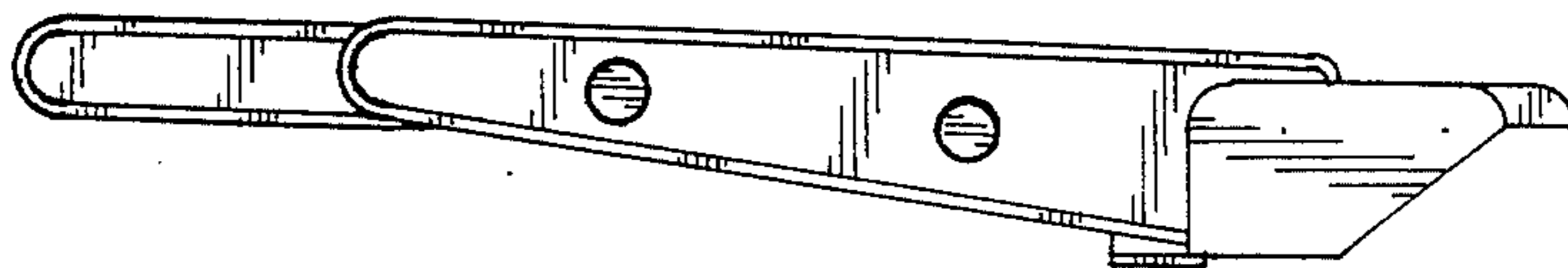

FIGURE 3

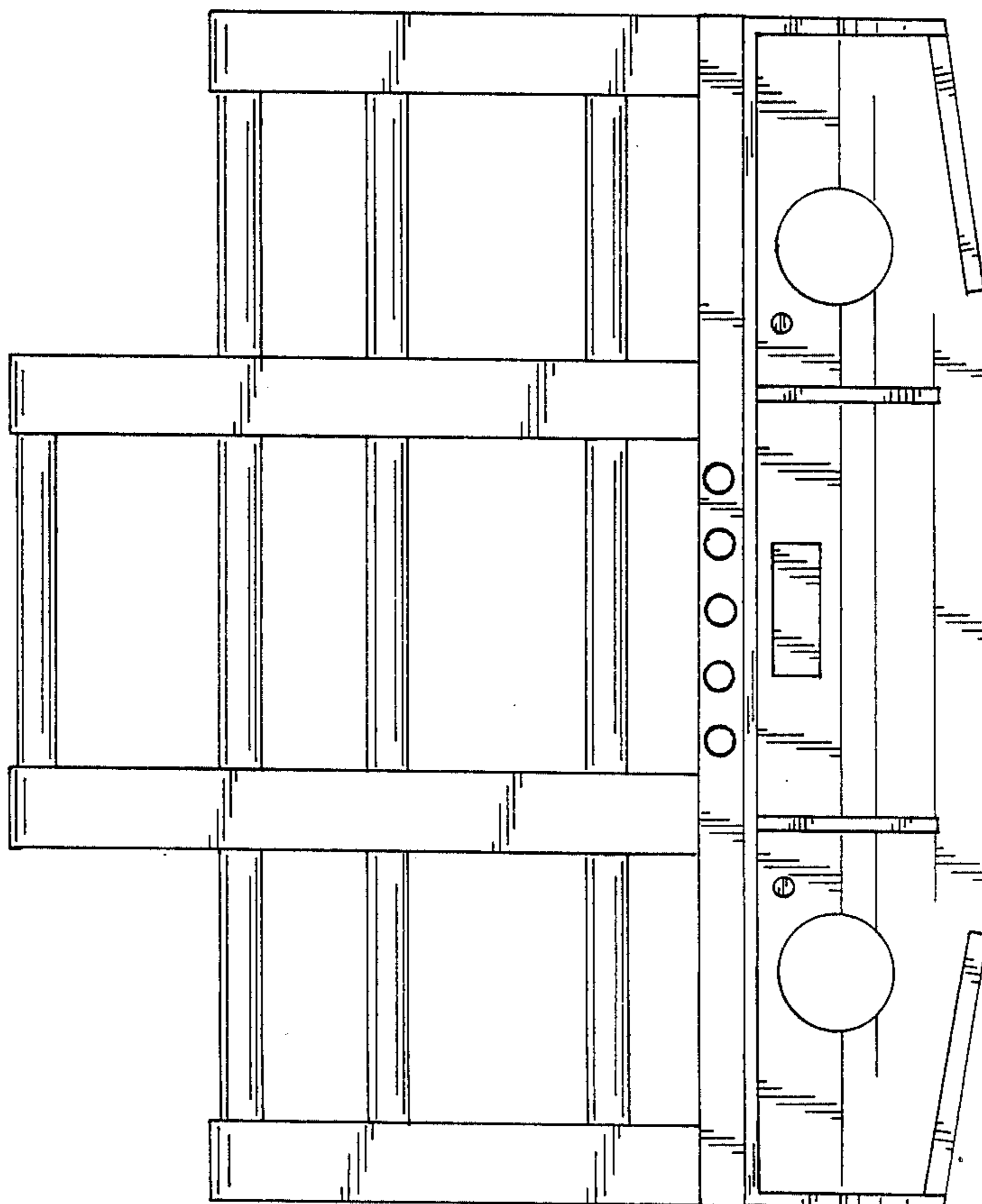

FIGURE 2