

[54] COMBINED TRACTOR TRAILER PIN PULLER AND FLASHLIGHT

4,572,040 2/1986 Metz ..... 81/463  
4,601,505 7/1986 Chilton ..... 294/26

[76] Inventor: Ernest G. Nickert, 8227 W. Lafayette, Detroit, Mich. 48209

FOREIGN PATENT DOCUMENTS

472478 12/1914 France ..... 294/26  
875178 9/1942 France ..... 294/26

[\*\*] Term: 14 Years

Primary Examiner—Bruce W. Dunkins  
Assistant Examiner—Clare E. Heflin  
Attorney, Agent, or Firm—Jerry T. Kearns

[21] Appl. No.: 82,366

[22] Filed: Aug. 6, 1987

[52] U.S. Cl. .... D8/14; D8/89; D8/105

[57] CLAIM

[58] Field of Search ..... D8/14, 105, 51; 294/14, 294/17, 26; 81/463; 7/100; 29/270, 271, 278, 280

The ornamental design for a combined tractor trailer pin puller and flashlight, as shown and described.

DESCRIPTION

[56] References Cited

U.S. PATENT DOCUMENTS

931,339 8/1909 Penington et al. .... 294/26  
1,193,950 8/1916 Vezina ..... 294/14  
2,999,310 9/1961 Pope ..... 294/26  
3,282,619 11/1966 Loosemore ..... 294/15  
4,034,594 7/1977 Morgan ..... 81/463

FIG. 1 is a front elevational view of a combined tractor trailer pin puller and flashlight showing my new design; FIG. 2 is a rear elevational view thereof; FIG. 3 is a left side elevational view thereof; FIG. 4 is a right side elevational view thereof; FIG. 5 is a top plan view thereof; FIG. 6 is a bottom plan view thereof; and, FIG. 7 is a perspective view thereof.

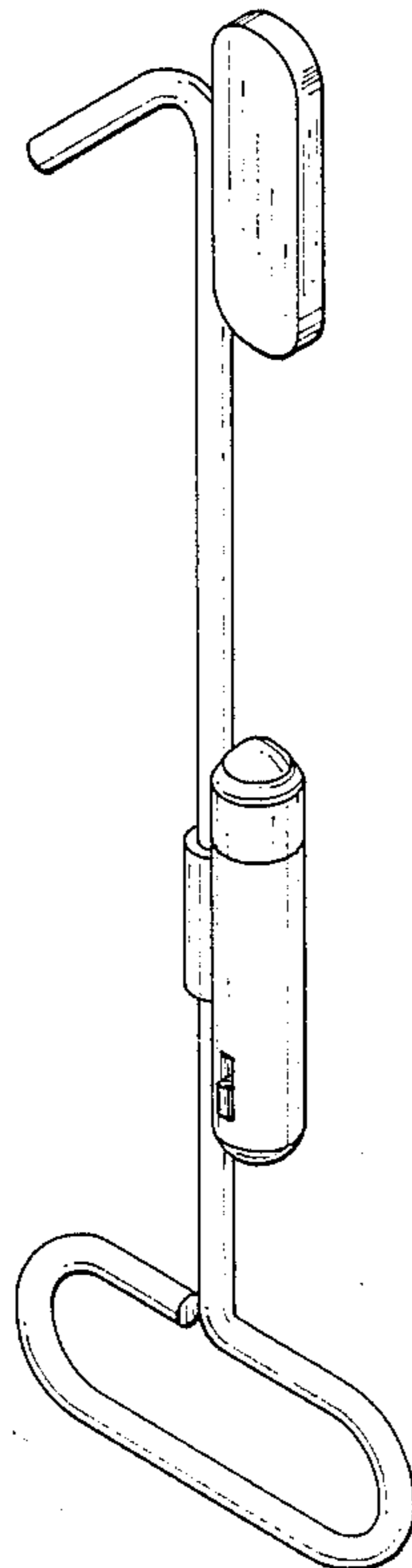

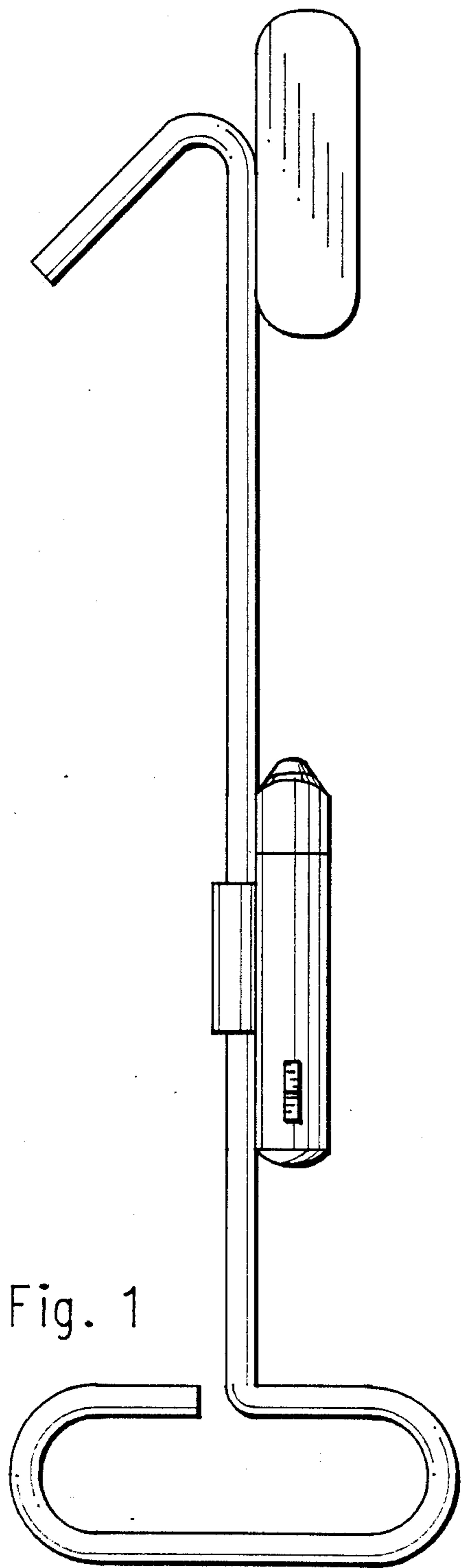

Fig. 1

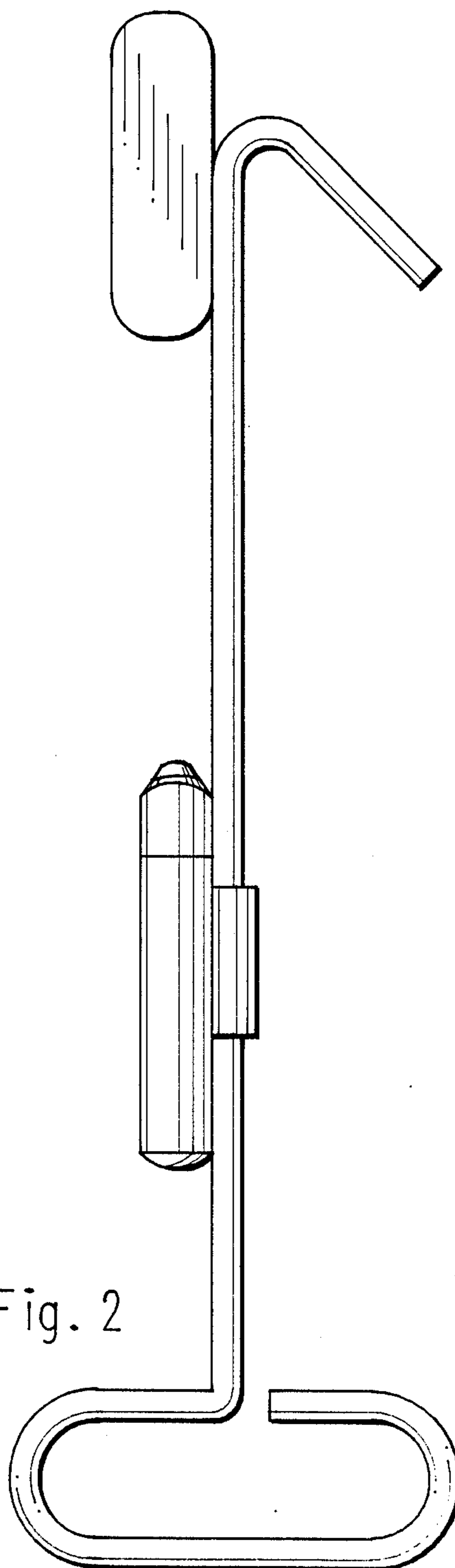

Fig. 2



Fig. 3



Fig. 4

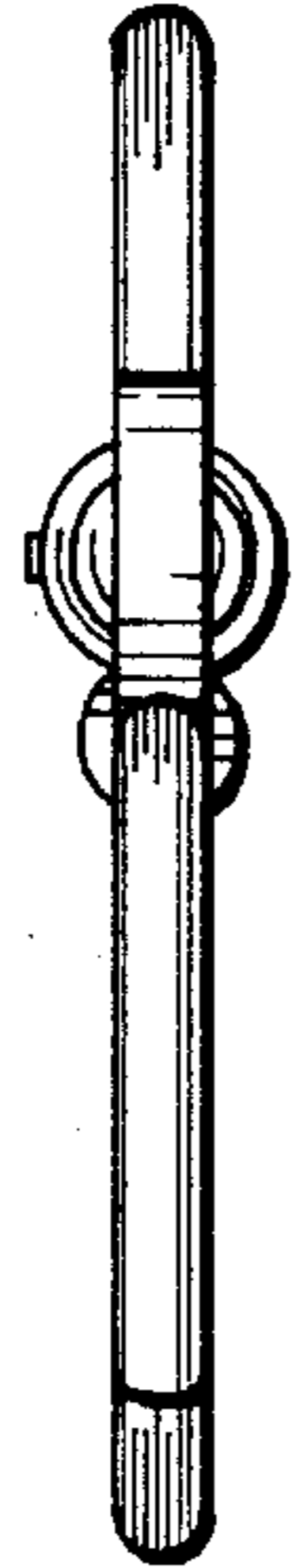

Fig. 5

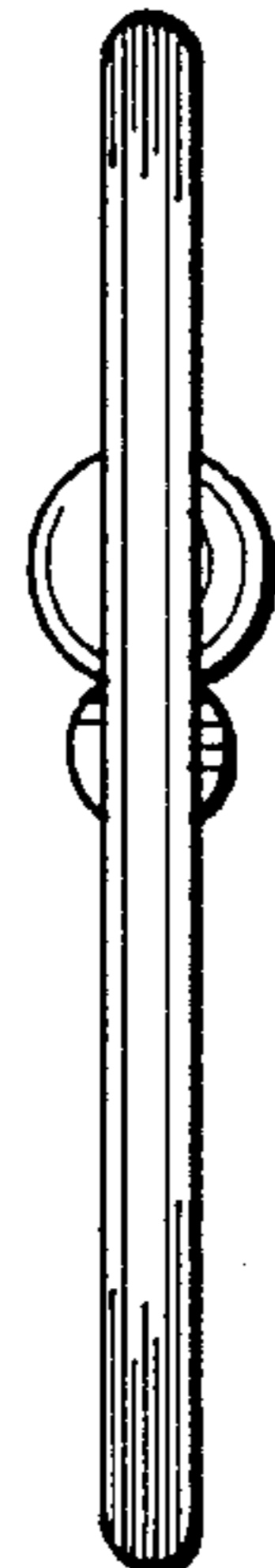

Fig. 6

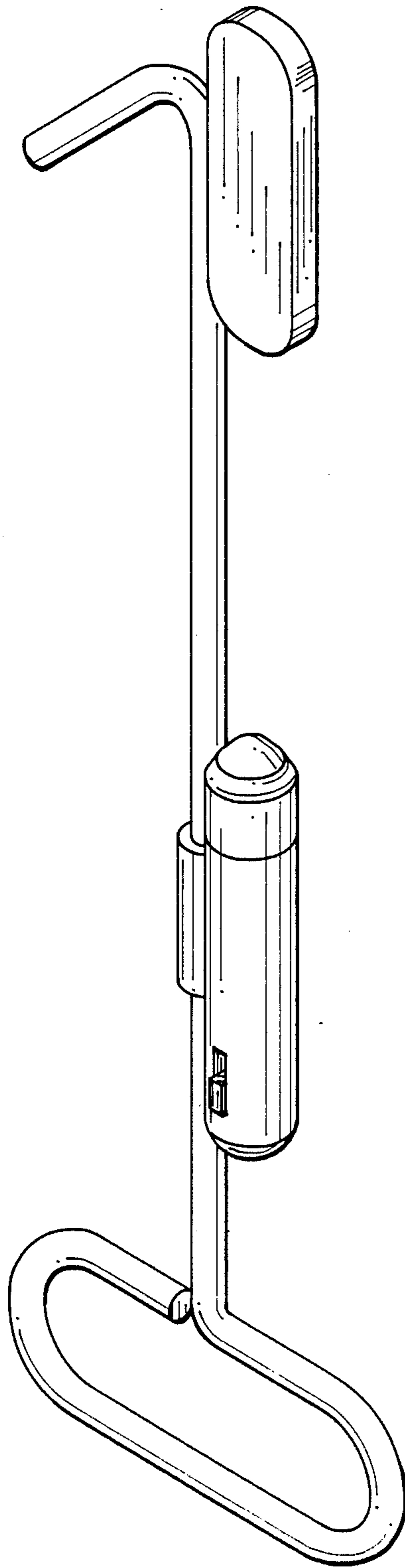

Fig. 7