

[54] **AIRCRAFT**

- [75] **Inventor: John J. Dupont, Lee's Summit, Mo.**
- [73] **Assignee: Skytrader Corporation, Kansas City, Mo.**
- [**] **Term: 14 Years**
- [21] **Appl. No.: 67,551**
- [22] **Filed: Jun. 29, 1987**
- [52] **U.S. Cl. D12/344; D12/324**
- [58] **Field of Search D12/319, 324, 326, 327, D12/328, 329, 336, 337, 341, 344; 244/55, 13**

[56] **References Cited**

U.S. PATENT DOCUMENTS

D. 177,563	5/1956	Fletcher	D12/344
D. 217,888	6/1970	Biemond	D12/324
3,807,665	4/1974	Coombe	244/55
4,662,582	5/1987	Brand	244/13

OTHER PUBLICATIONS

Jane's all the World's Aircraft, 1983 & 1984, "Hawk Gafhawk 125" (lower).

Primary Examiner—Wallace R. Burke
Assistant Examiner—Kay H. Chin
Attorney, Agent, or Firm—Hovey, Williams, Timmons & Collins

CLAIM

[57] The ornamental design for an aircraft, as shown and described.

DESCRIPTION

FIG. 1 is a right side elevation view of an aircraft showing my new design;
FIG. 2 is a top plan view thereof;
FIG. 3 is a front elevation thereof;
FIG. 4 is a rear elevation view thereof;
FIG. 5 is a bottom plan view thereof; and
FIG. 6 is a left side elevation thereof.

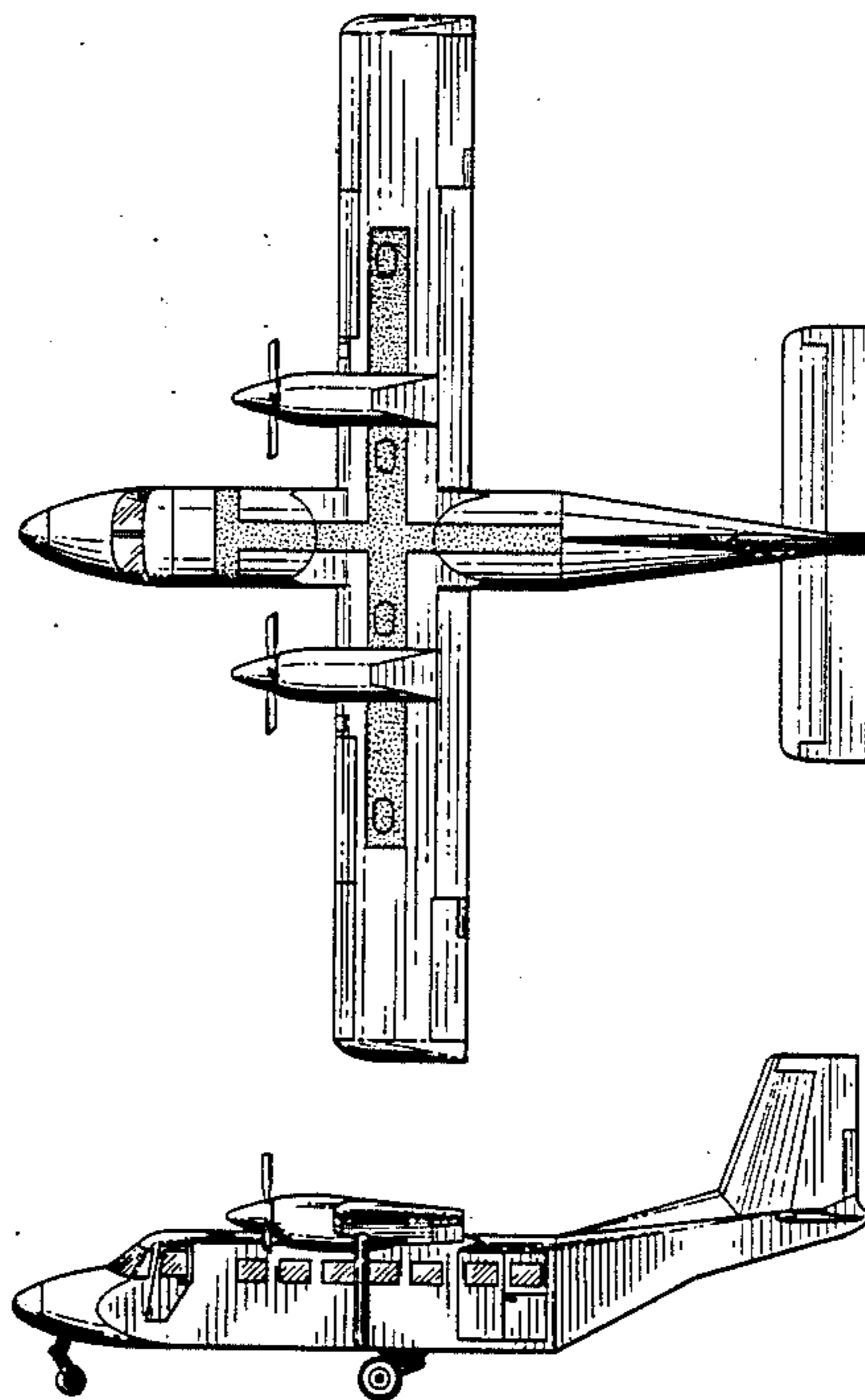

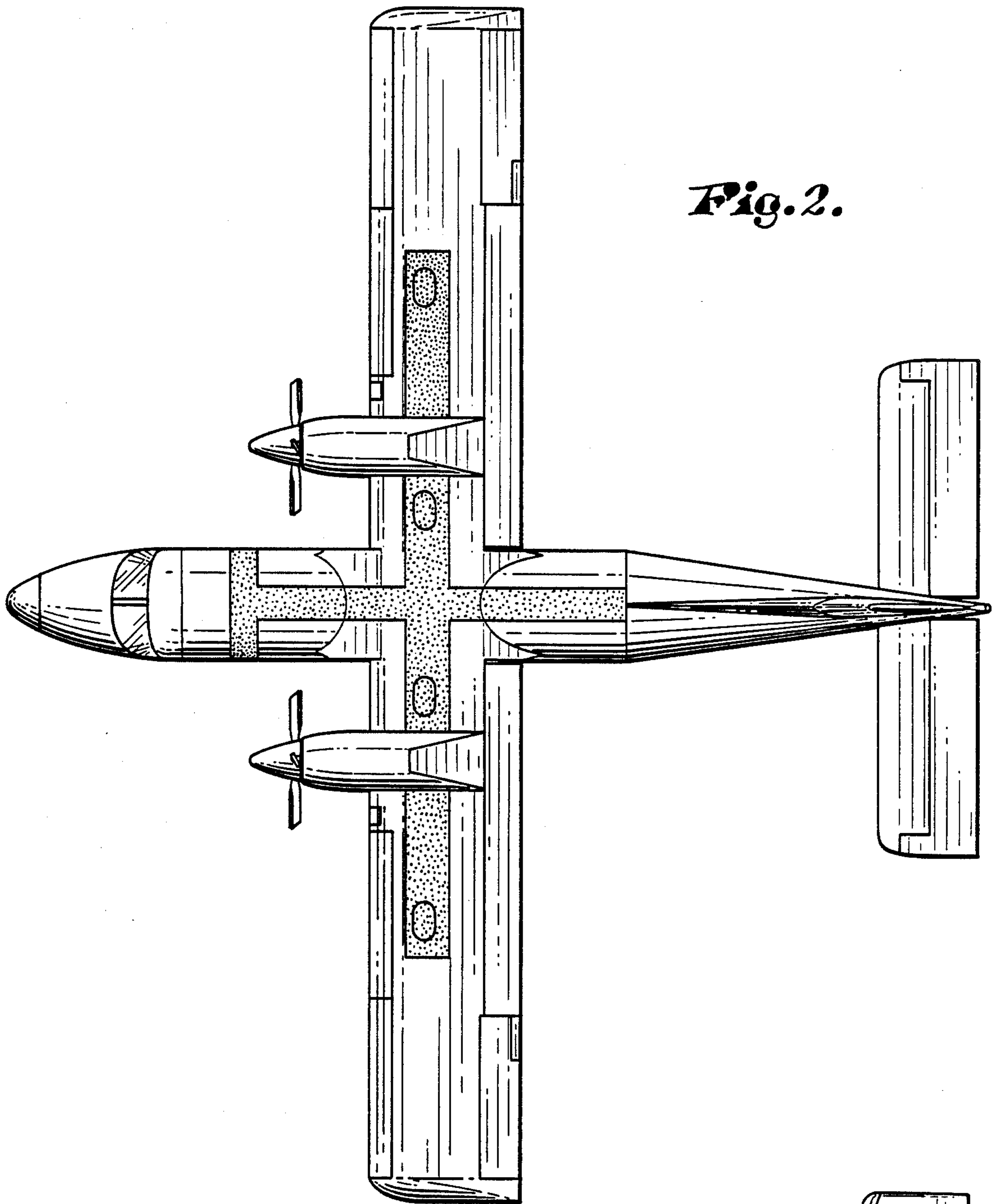

Fig. 2.

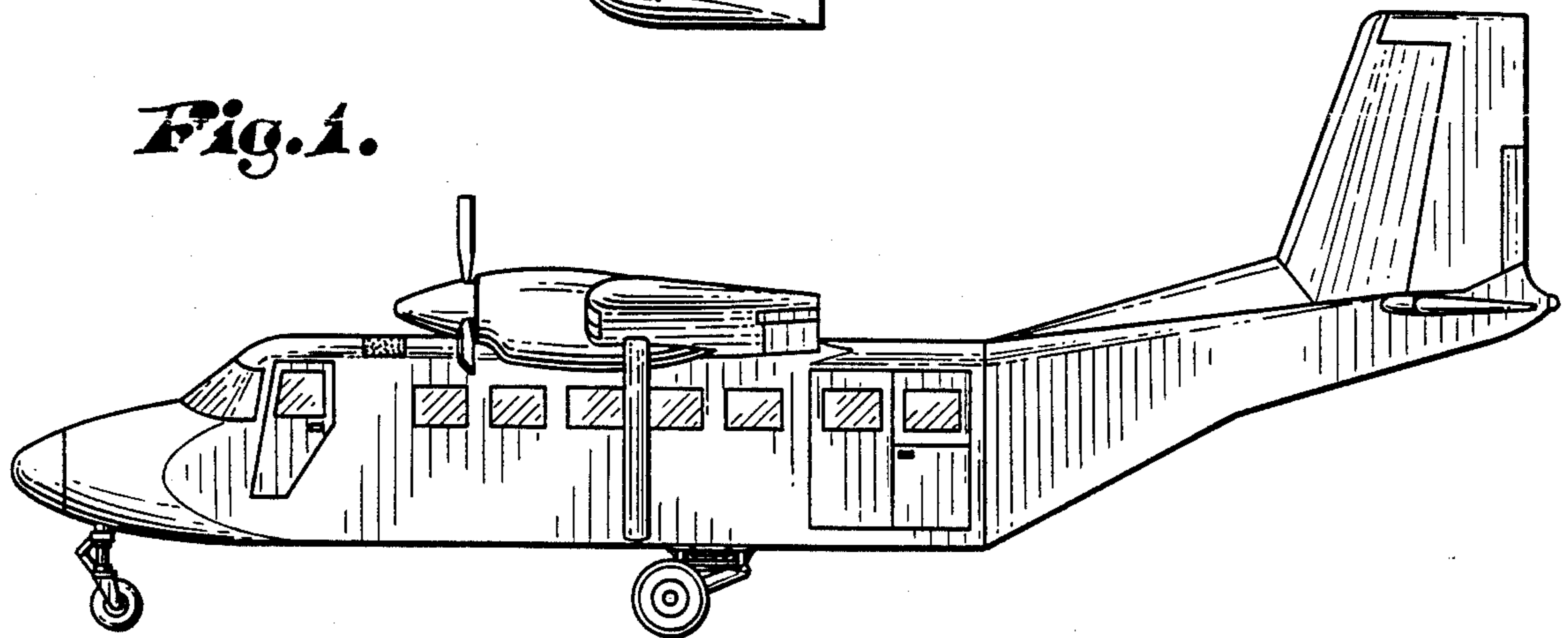

Fig. 1.

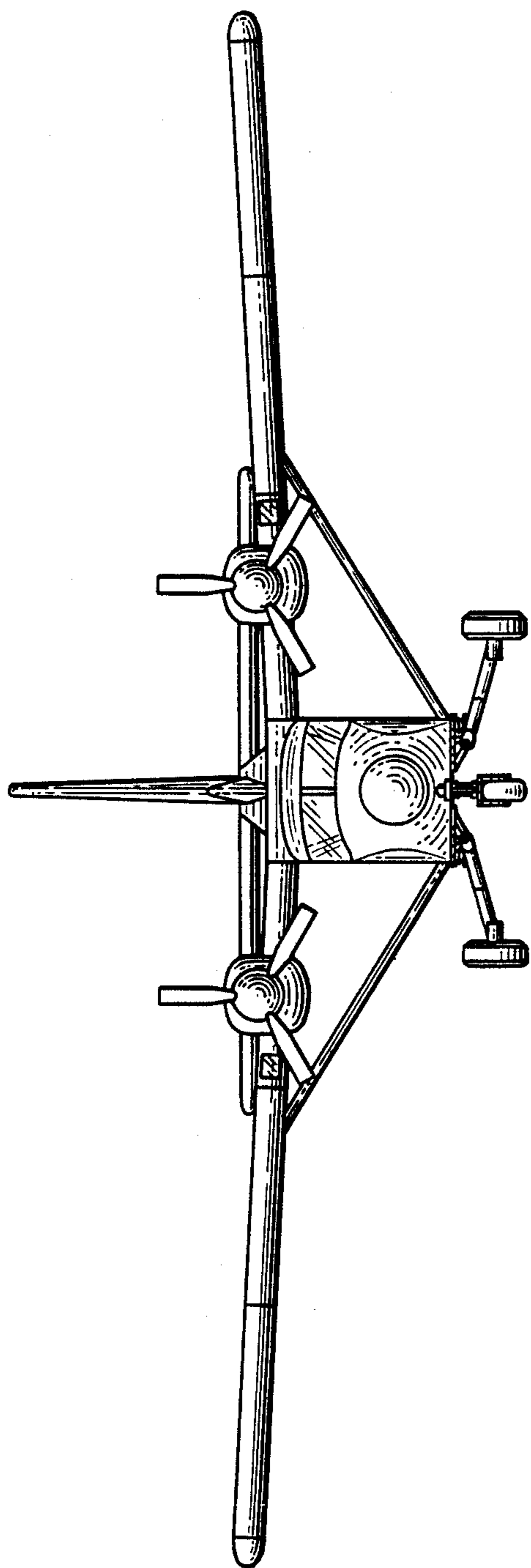

Fig. 3.

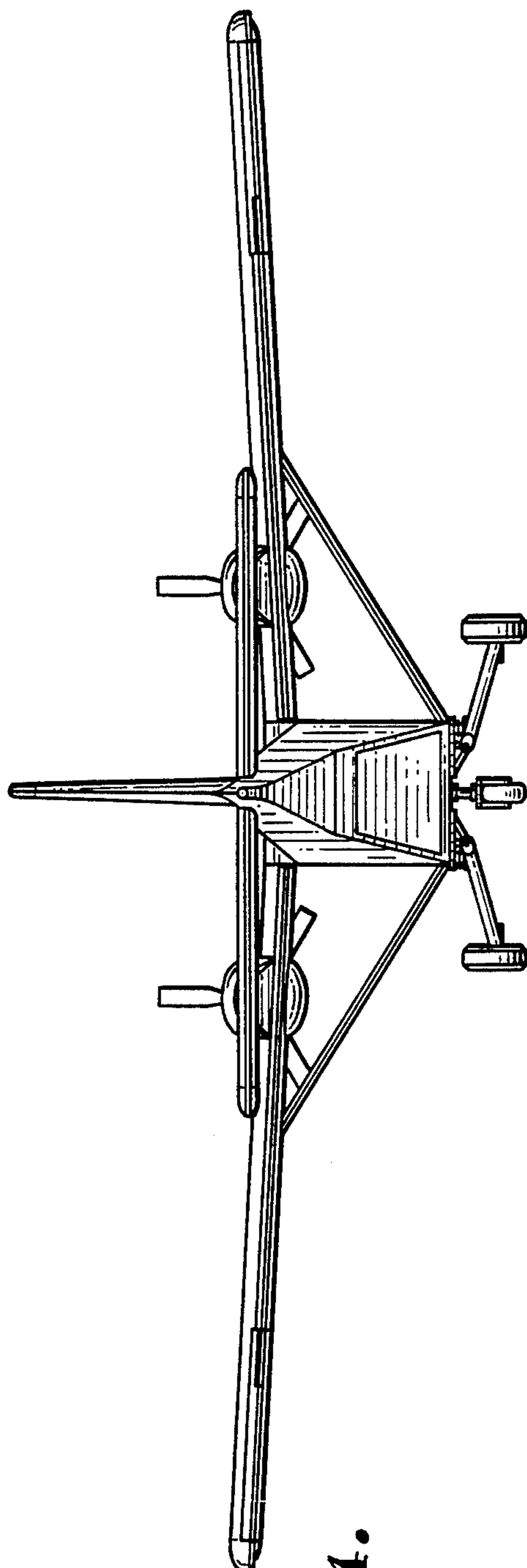

Fig. 4.

Fig. 5.

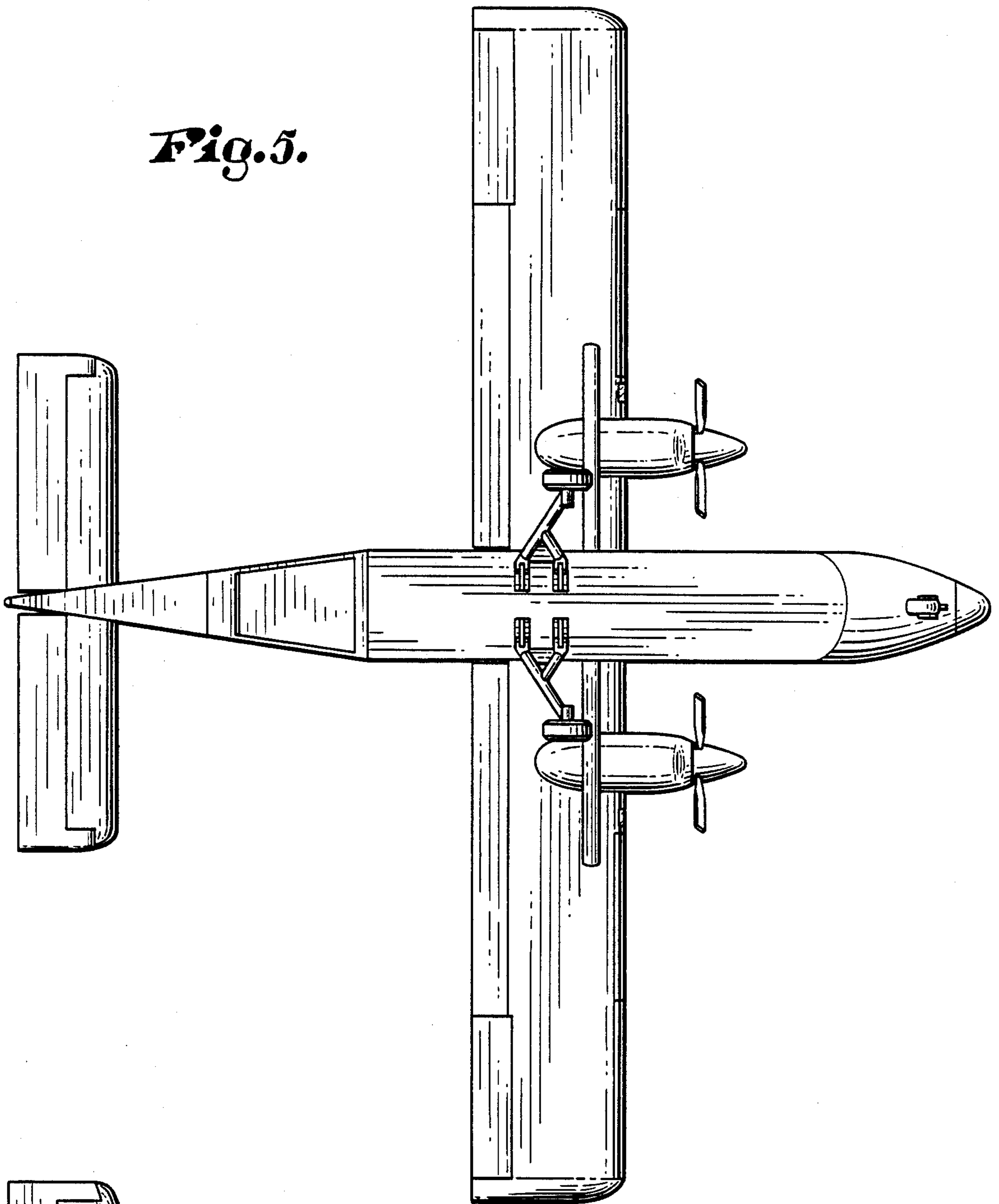

Fig. 6.

