

[54] AIR VEHICLE

[75] Inventor: George Ninkovich, Richmond, Canada  
[73] Assignee: Hystar Aerospace Development Corporation, Vancouver, Canada

[\*\*] Term: 14 Years

[21] Appl. No.: 35,947

[22] Filed: Apr. 8, 1987

[30] Foreign Application Priority Data

Feb. 17, 1986 [JP] Japan ..... 62-5777  
[52] U.S. Cl. .... D12/325; D21/87  
[58] Field of Search ..... D12/319, 320, 323, 325; D21/82, 84, 85, 86, 87, 90, 91, 108, 150; 446/36, 85, 88, 93, 94, 108, 116, 118, 120, 220, 225, 230, 231, 232; 244/23 C, 24, 26, 29, 34 A, 34 R

[56]

References Cited

U.S. PATENT DOCUMENTS

D. 213,731	4/1969	Hsi .....	D12/323
2,935,275	5/1960	Grayson .....	D12/325
3,477,168	11/1969	Troglew .....	244/23 C
4,461,436	7/1984	Messiwa .....	244/23 C
4,685,640	8/1987	Warrington et al. ....	244/29

Primary Examiner—Charles A. Rademaker  
Attorney, Agent, or Firm—Rogers, Bereskin & Parr

[57]

CLAIM

The ornamental design for an air vehicle, as shown and described.

DESCRIPTION

FIG. 1 is a top perspective view of an air vehicle showing my new design;  
FIG. 2 is a bottom perspective view thereof;  
FIG. 3 is a top plan view thereof;  
FIG. 4 is a bottom plan view thereof;  
FIG. 5 is a side elevational view thereof, the side opposite being a mirror image; and,  
FIG. 6 is a vertical sectional view on line A—A of FIG. 3.

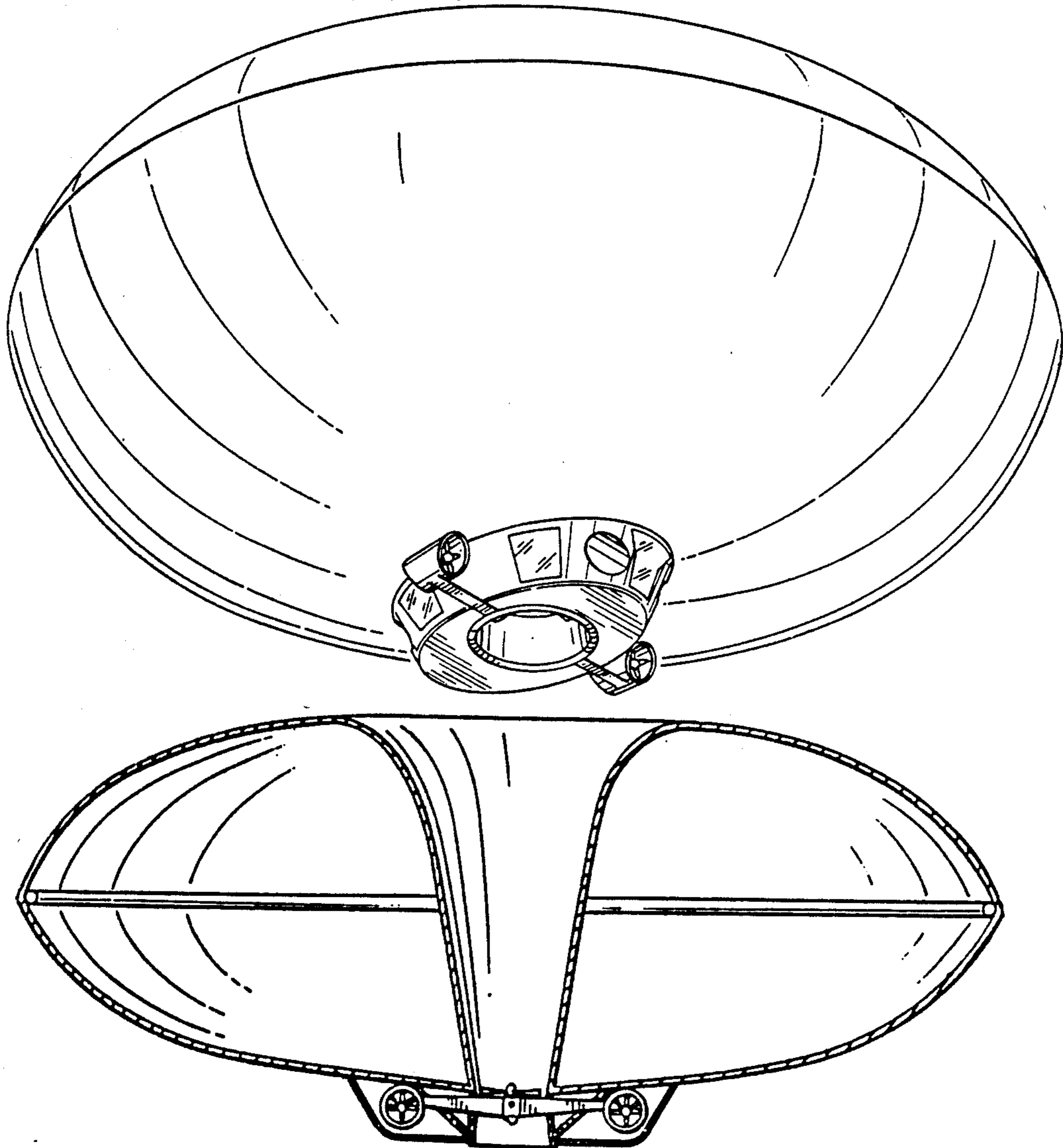

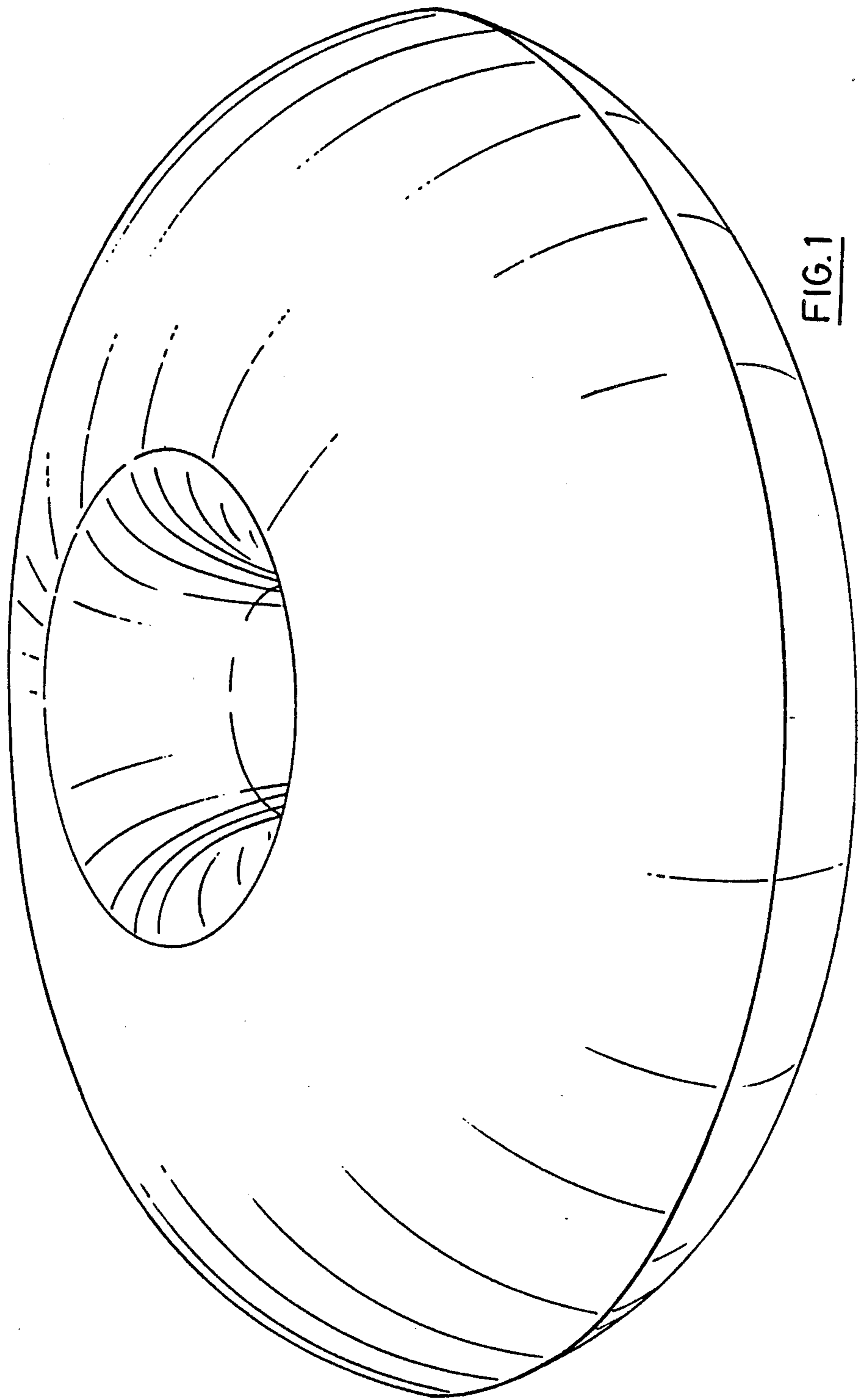

FIG. 1

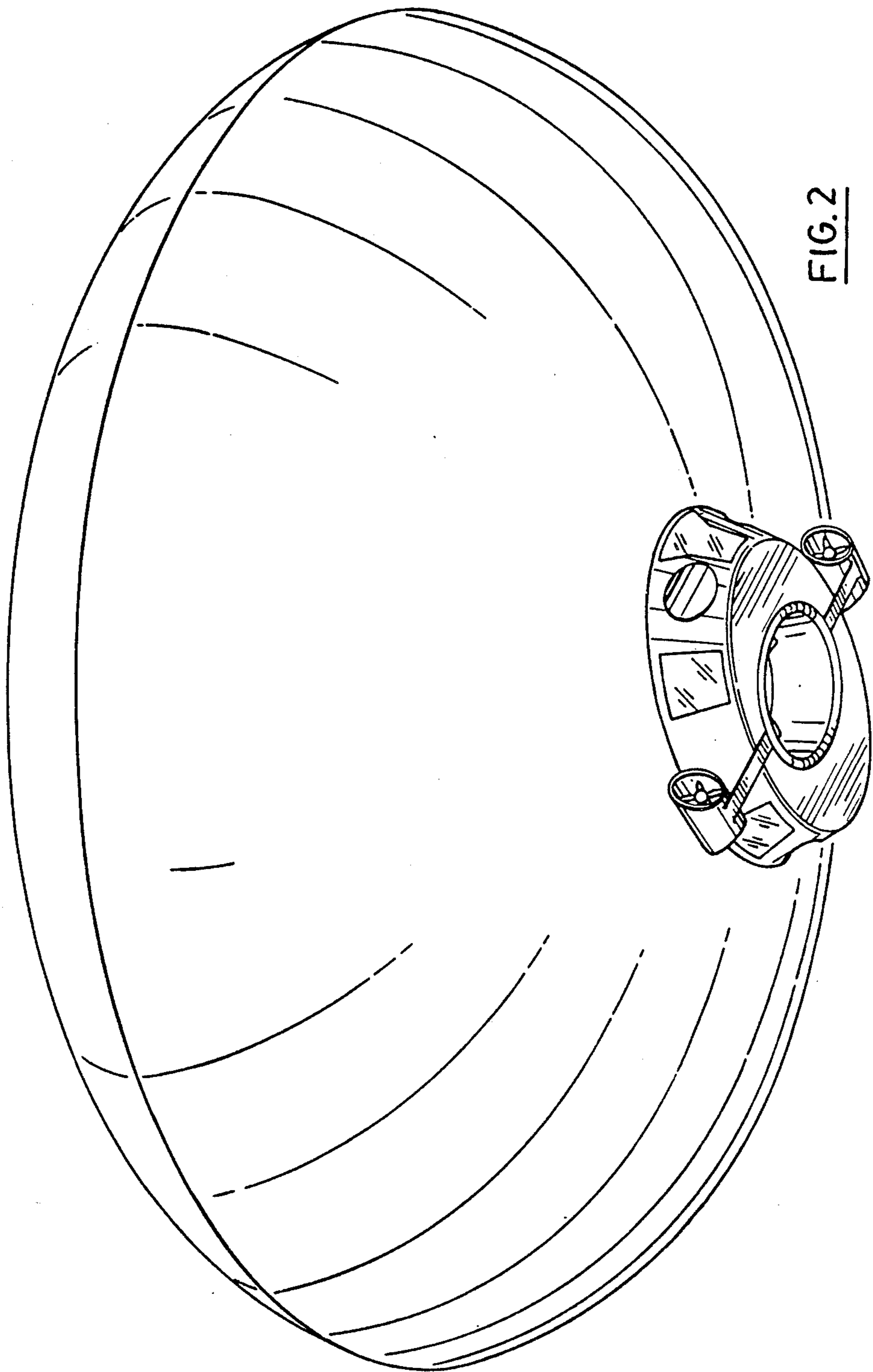

FIG. 2

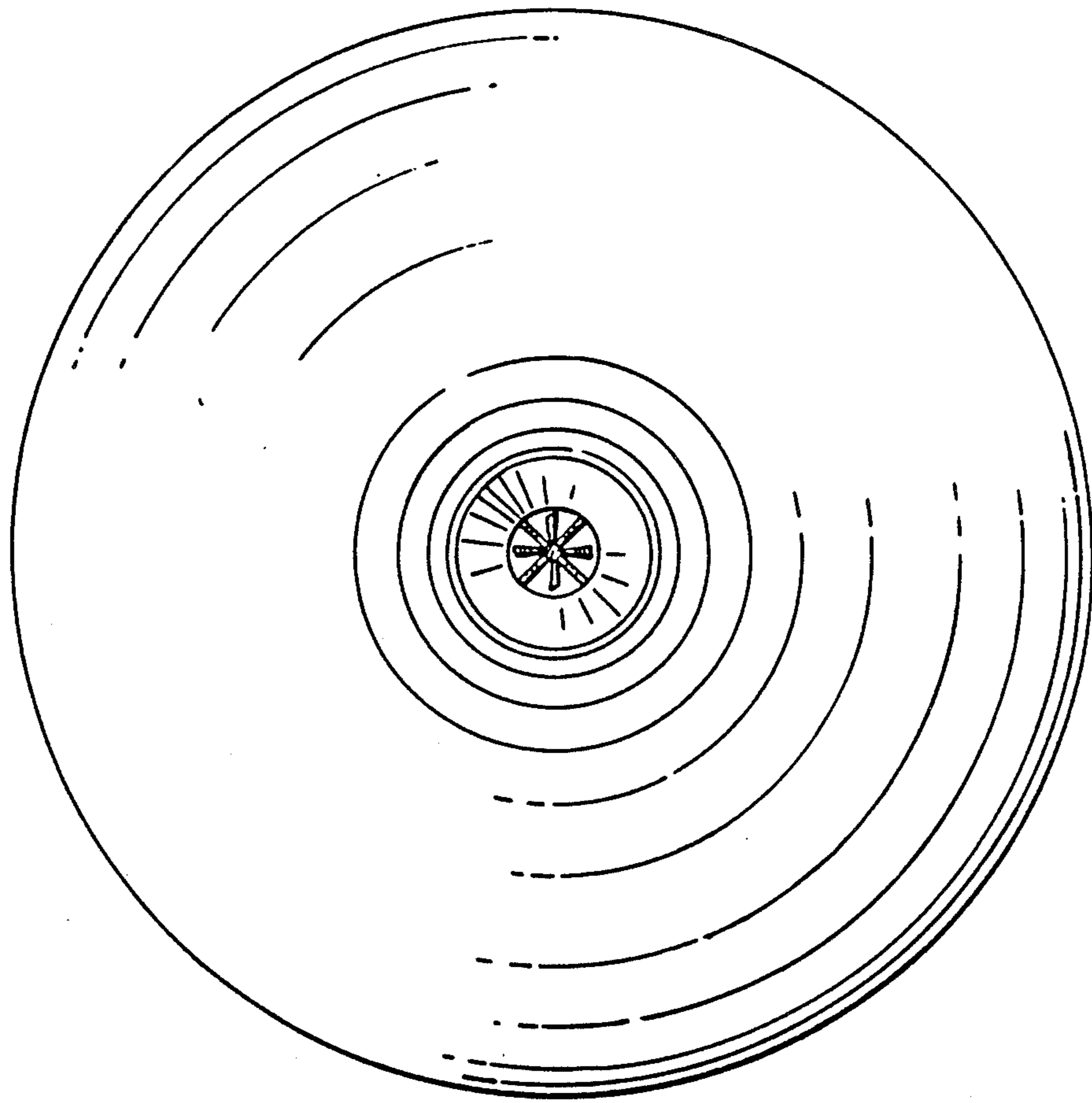

FIG. 3

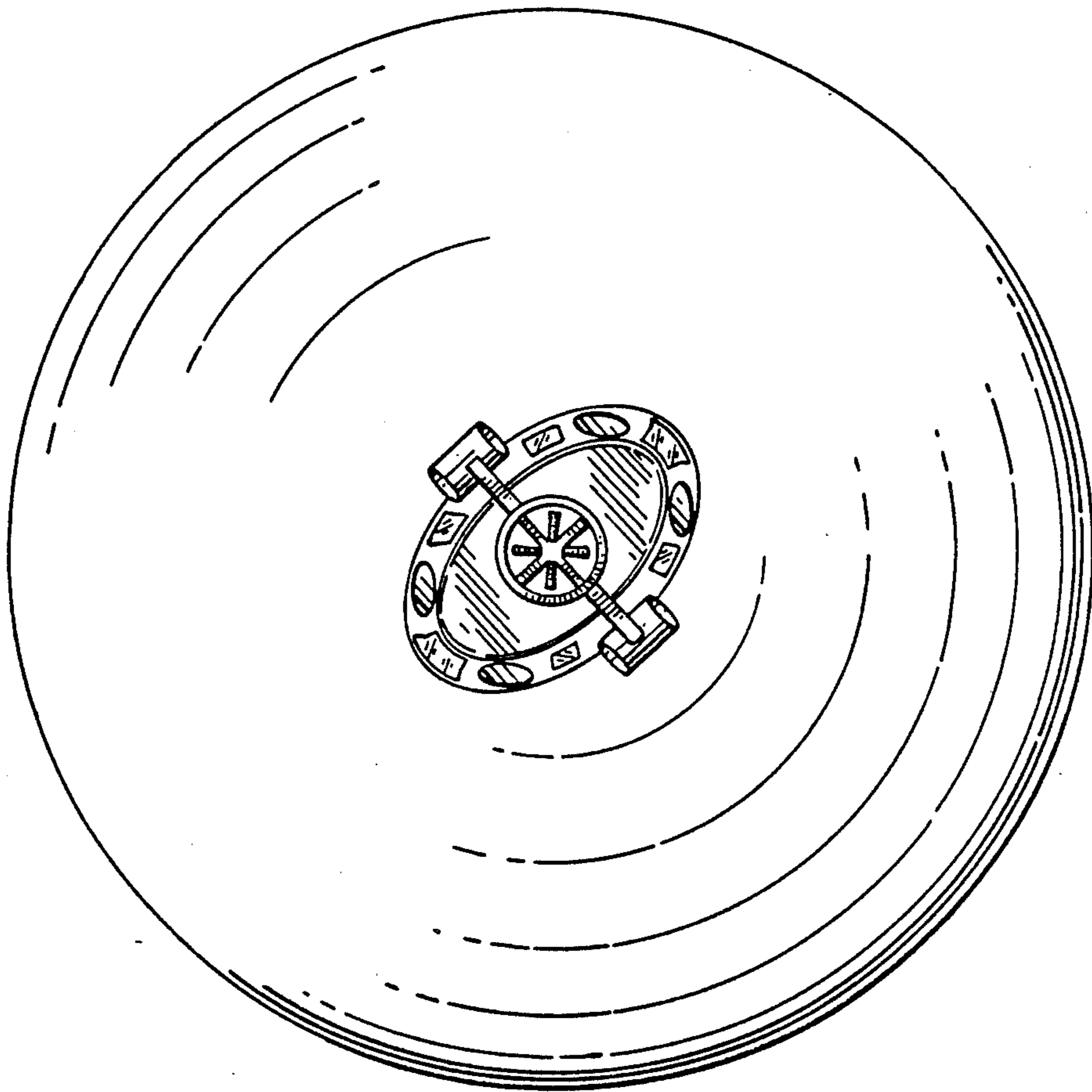

FIG. 4

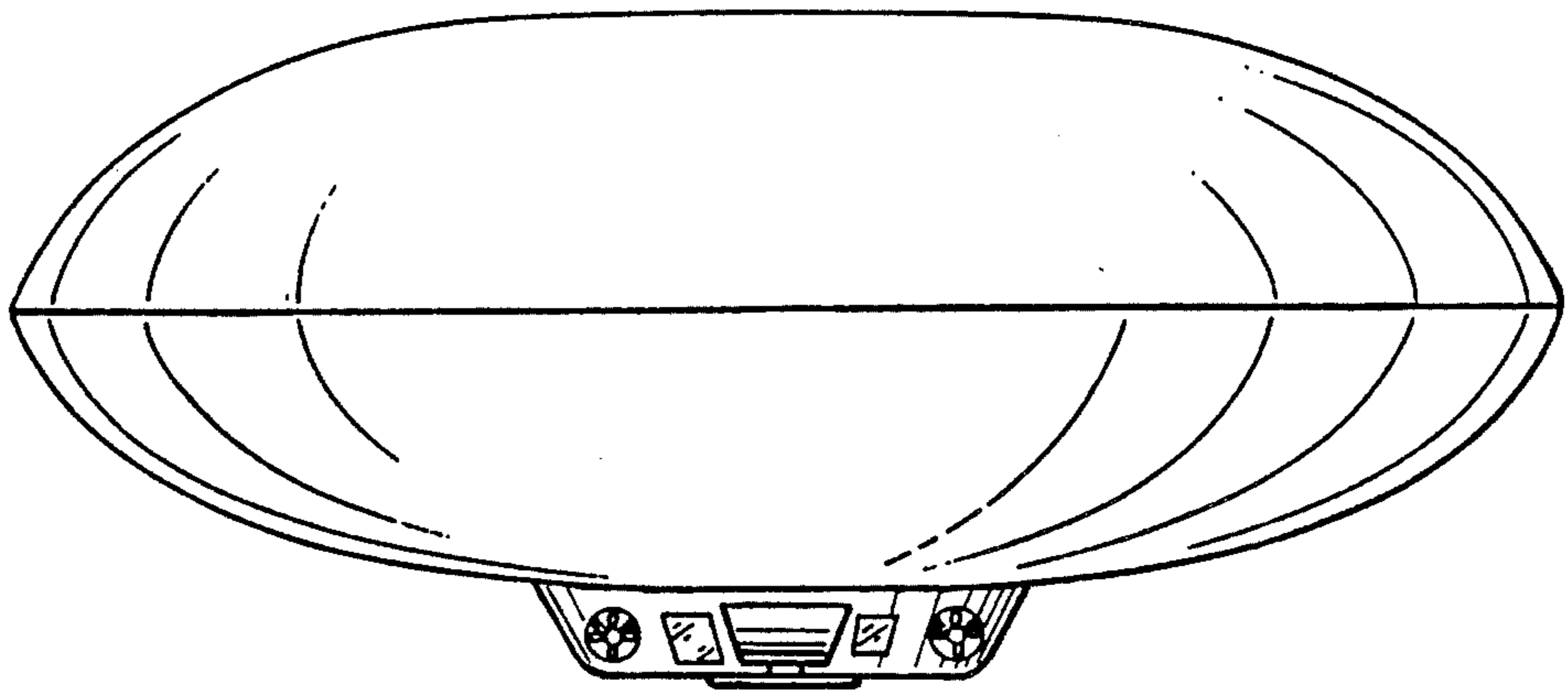

FIG. 5

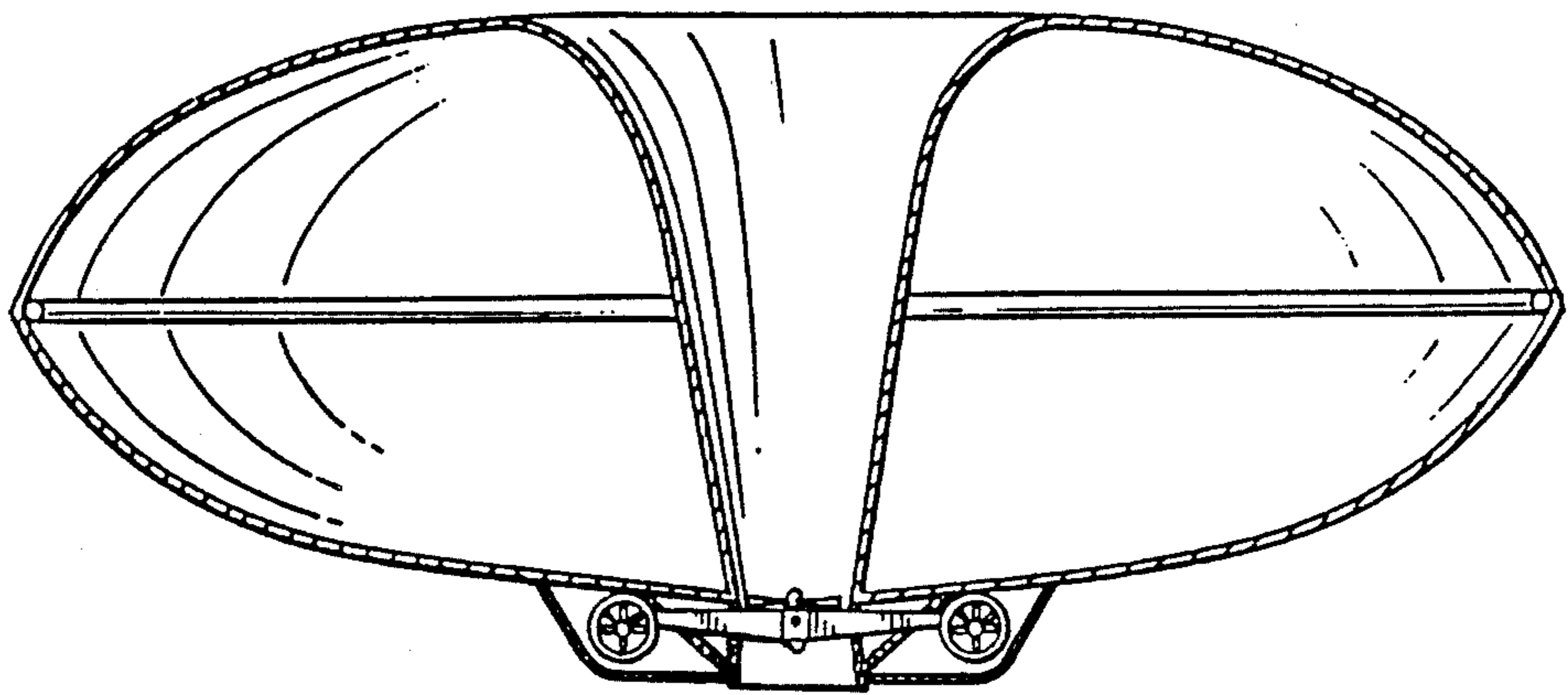

FIG. 6