

United States Patent [19]

Marks

[11] Patent Number: Des. 307,822

[45] Date of Patent: ** May 15, 1990

[54] SPECTACLE CASE FOR ATTACHMENT TO A SUNVISOR

1,513,776 11/1924 Wells D3/34 X
1,748,430 2/1930 Stringham D3/34 X

[75] Inventor: Robert J. Marks, Las Vegas, Nev.

Primary Examiner—James R. Largen
Assistant Examiner—Y. Brunot
Attorney, Agent, or Firm—Harris Zimmerman

[73] Assignee: California Optical Leather, Inc., San Leandro, Calif.

[**] Term: 14 Years

[21] Appl. No.: 886,888

[22] Filed: Jul. 18, 1986

[52] U.S. Cl. D3/34

[58] Field of Search D3/34

[57] CLAIM

The ornamental design for a spectacle case for attachment to a sunvisor, as shown and described.

DESCRIPTION

FIG. 1 is a perspective view of a spectacle case for attachment to a sunvisor showing my new design; FIG. 2 is a top plan view thereof; FIG. 3 is a front elevational view; FIG. 4 is a rear elevational view; FIG. 5 is an end elevational view, the opposite end being a mirror image thereof; and FIG. 6 is a bottom plan view.

[56] References Cited

U.S. PATENT DOCUMENTS

D. 205,421 8/1966 Hueber et al. D3/34
D. 262,585 1/1982 Anema D3/34 X

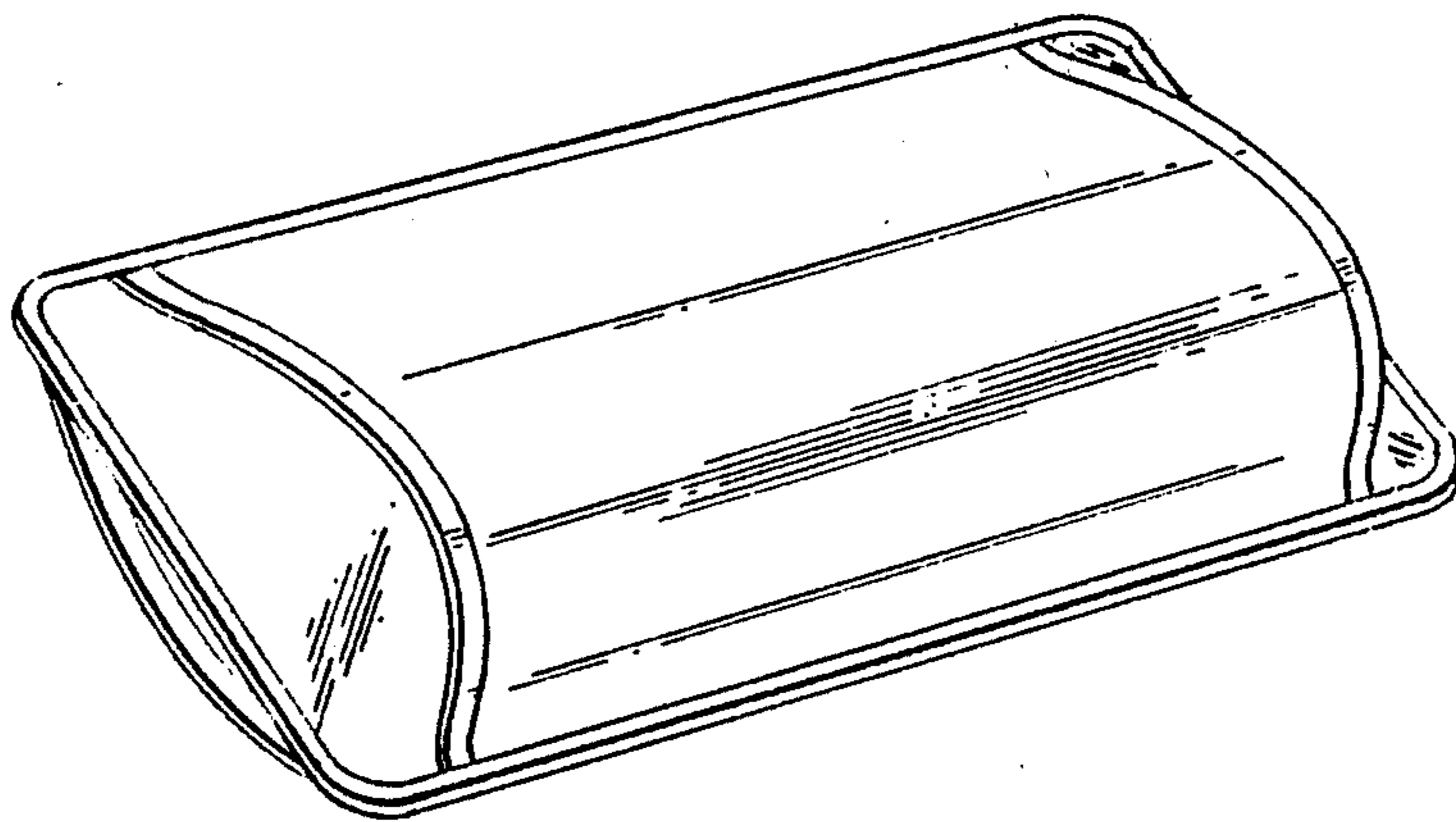

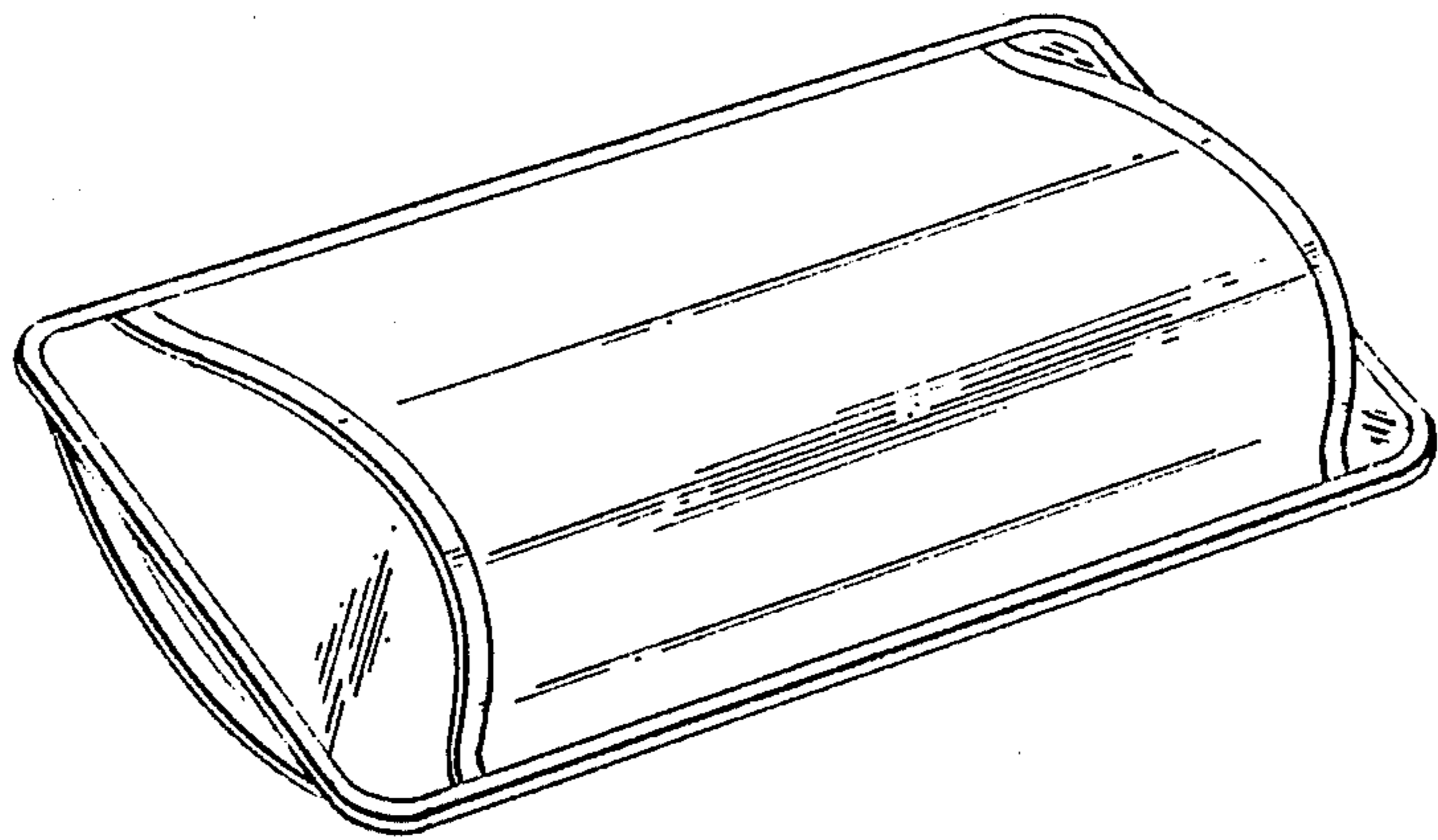

FIG - 1



FIG - 5

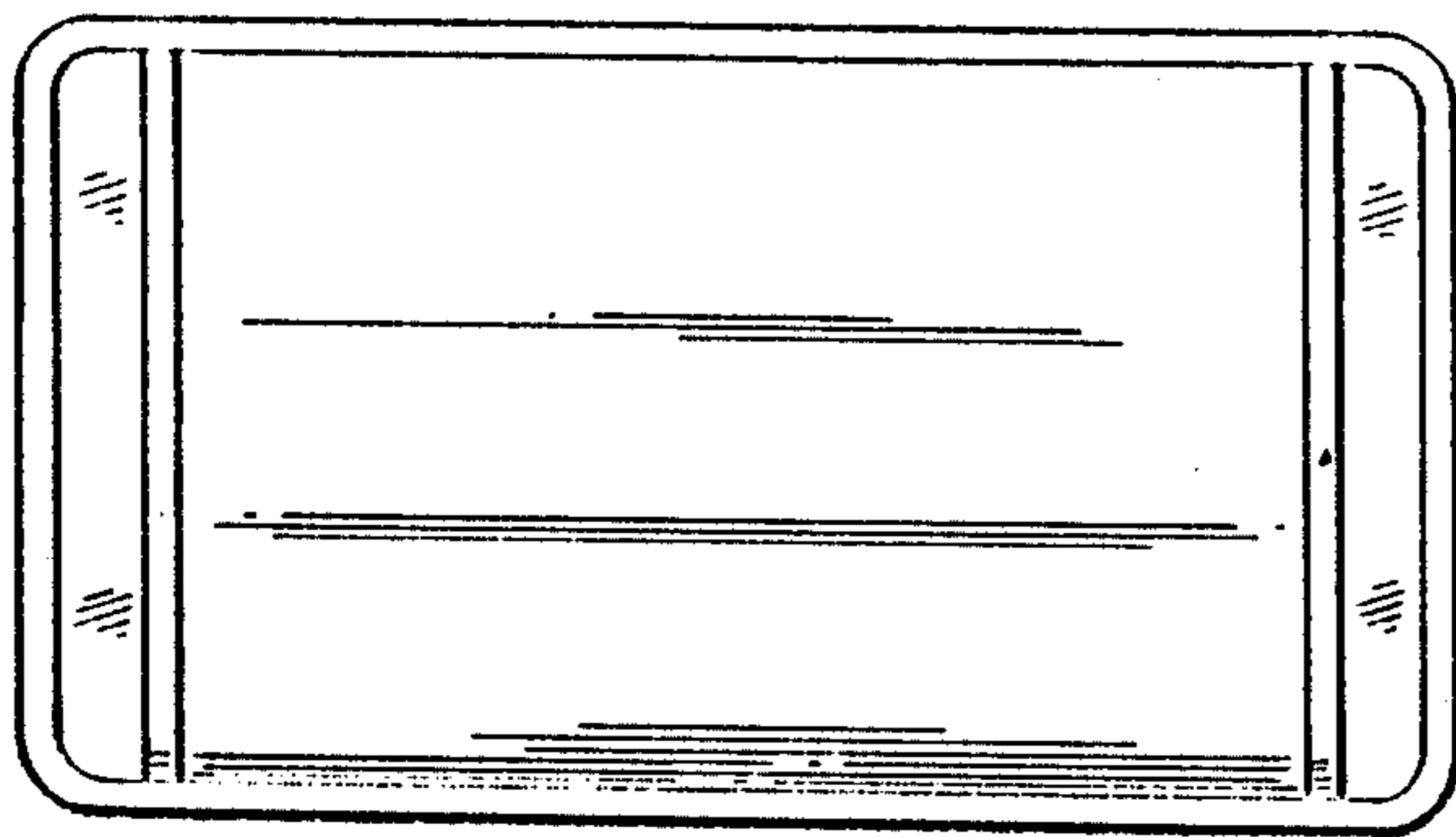

FIG - 2

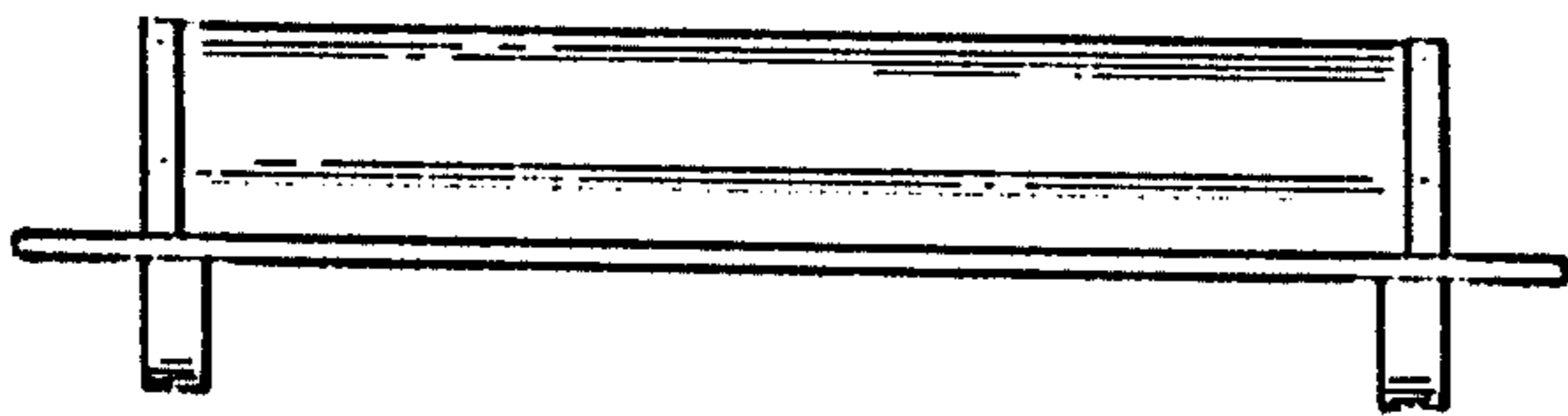

FIG - 3

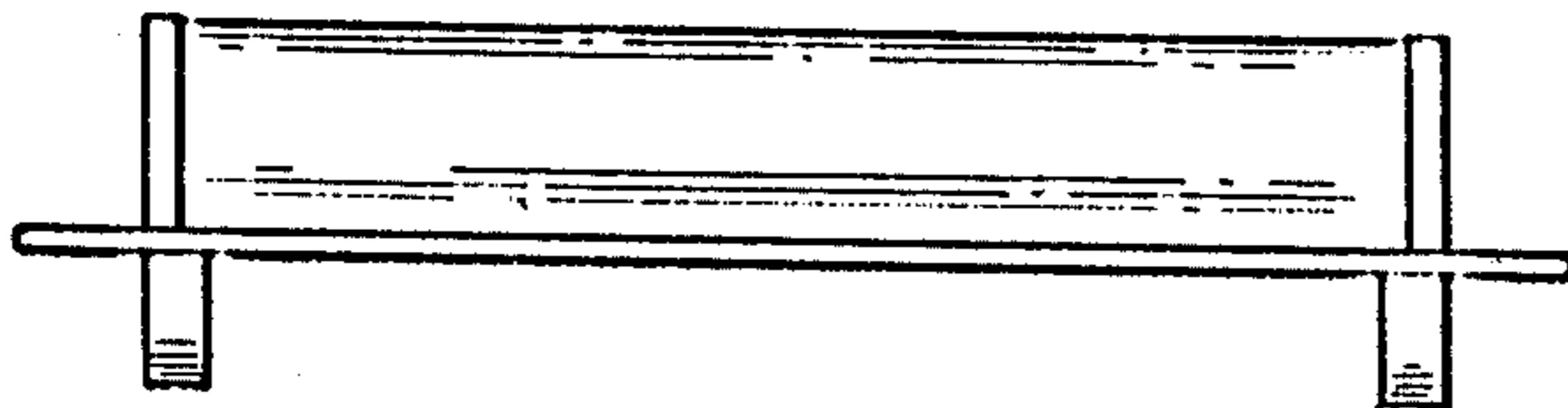

FIG - 4

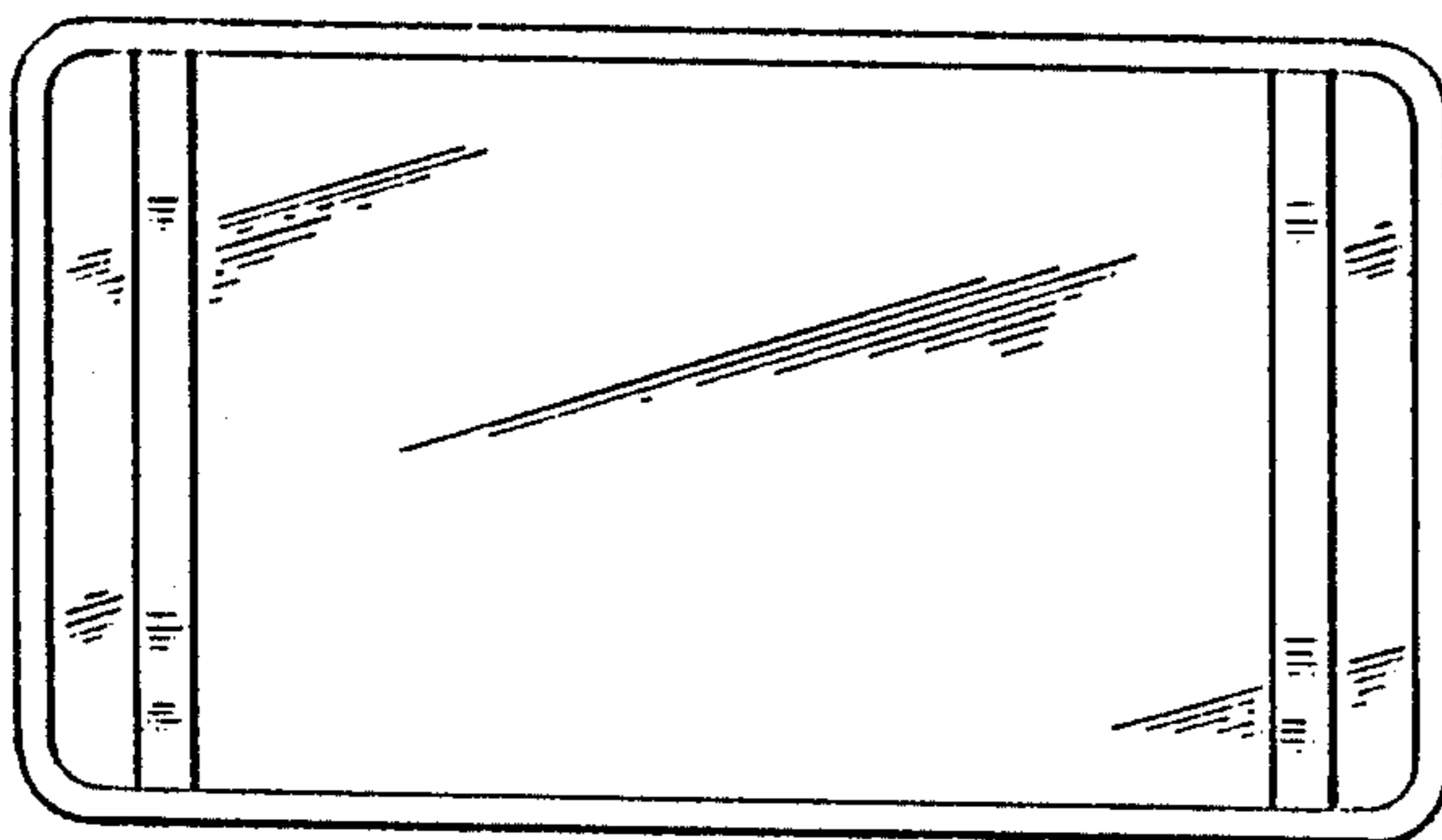

FIG - 6