

[54] **BAG FOR MOTORCYCLE**

[76] **Inventor: Hisashi Kushitani, No. 9-14,4-chome, Yoga, Setagaya-ku, Tokyo, Japan**

[**] **Term: 14 Years**

[21] **Appl. No.: 931,434**

[22] **Filed: Nov. 14, 1986**

[52] **U.S. Cl. D12/158**

[58] **Field of Search D3/71, 76, 77, 78, 79; D12/158.11; 206/335; 150/166, 167, 164, 165; 190/103, 18 A, 104, 105, 120, 53, 18 R; 224/30 R, 30 A, 31, 32 R, 32 A, 35, 37, 38, 39, 40, 309, 311, 42.11-42.19, 42.20, 42.21, 42.04, 325, 320, 314, 34, 35; 280/202, 769**

[56] **References Cited**

U.S. PATENT DOCUMENTS

3,903,944 8/1975 Montgomery et al. 224/32 R
4,260,085 4/1981 Jefferson 224/31
4,359,233 11/1982 Jackson et al. 224/32 R
4,469,256 9/1984 McEwen 224/32 R

FOREIGN PATENT DOCUMENTS

3125460 1/1983 Fed. Rep. of Germany 224/35
2080222 2/1982 United Kingdom 224/35

OTHER PUBLICATIONS

Cycle Magazine, Jan. 1975, Eclipse Tank Bag, p. 64.
Automotive Parts & Accessories, 10/77, p. 137, "Piggy Back" Type.

J. C. Whitney & Co., Parts & Accessories, 1982, p. 220, "Piggy Back" Type.

Primary Examiner—Nelson C. Holtje
Assistant Examiner—Antoine D. Davis
Attorney, Agent, or Firm—Robert E. Burns; Emmanuel J. Lobato

[57] **CLAIM**

The ornamental design for a bag for motorcycle, as shown and described.

DESCRIPTION

FIG. 1 is a top plan view of a bag for motorcycle showing my new design.
FIG. 2 is a front elevational view thereof.
FIG. 3 is a bottom plan view thereof.
FIG. 4 is a rear elevational view thereof.
FIG. 5 is a right side elevational view thereof;
FIG. 6 is a left side elevational view thereof;
FIG. 7 is a front, right side perspective view thereof;
FIG. 8 is a front, right side perspective view thereof, showing the bag extended with the magnetic flat plate unfolded and elastic corded hooks drawn out;
FIG. 9 is a left side elevational view thereof, showing the bag on a reduced scale, on a fuel tank of a motorcycle. The broken line showing of a motorcycle is for illustrative purposes only and forms no part of the claimed design;
FIG. 10 is a right side elevational view thereof, showing the bag on a reduced scale, on the rear seat of a motorcycle. The broken line showing of a motorcycle is for illustrative purposes only and forms no part of the claimed design.

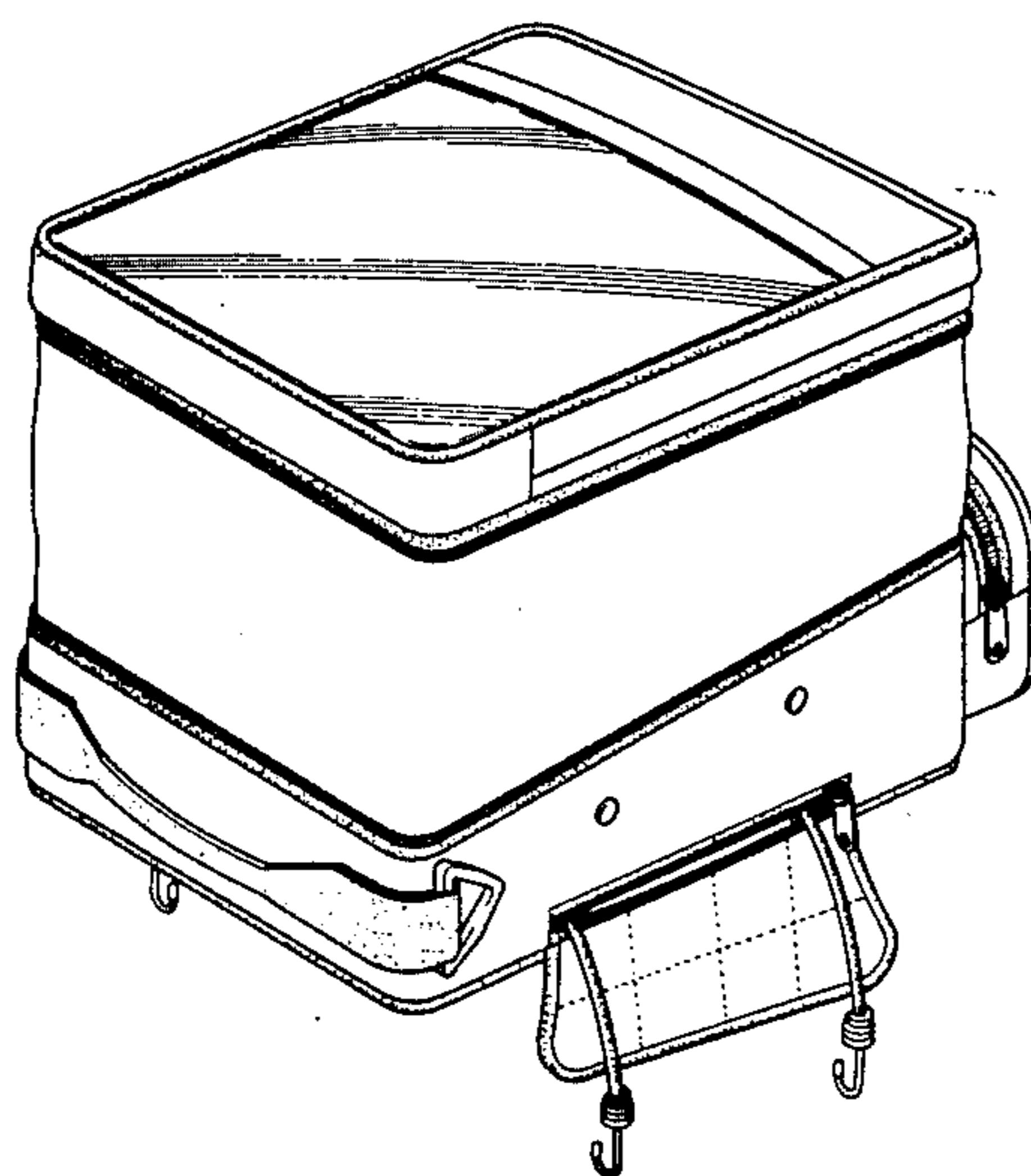

FIG. 1

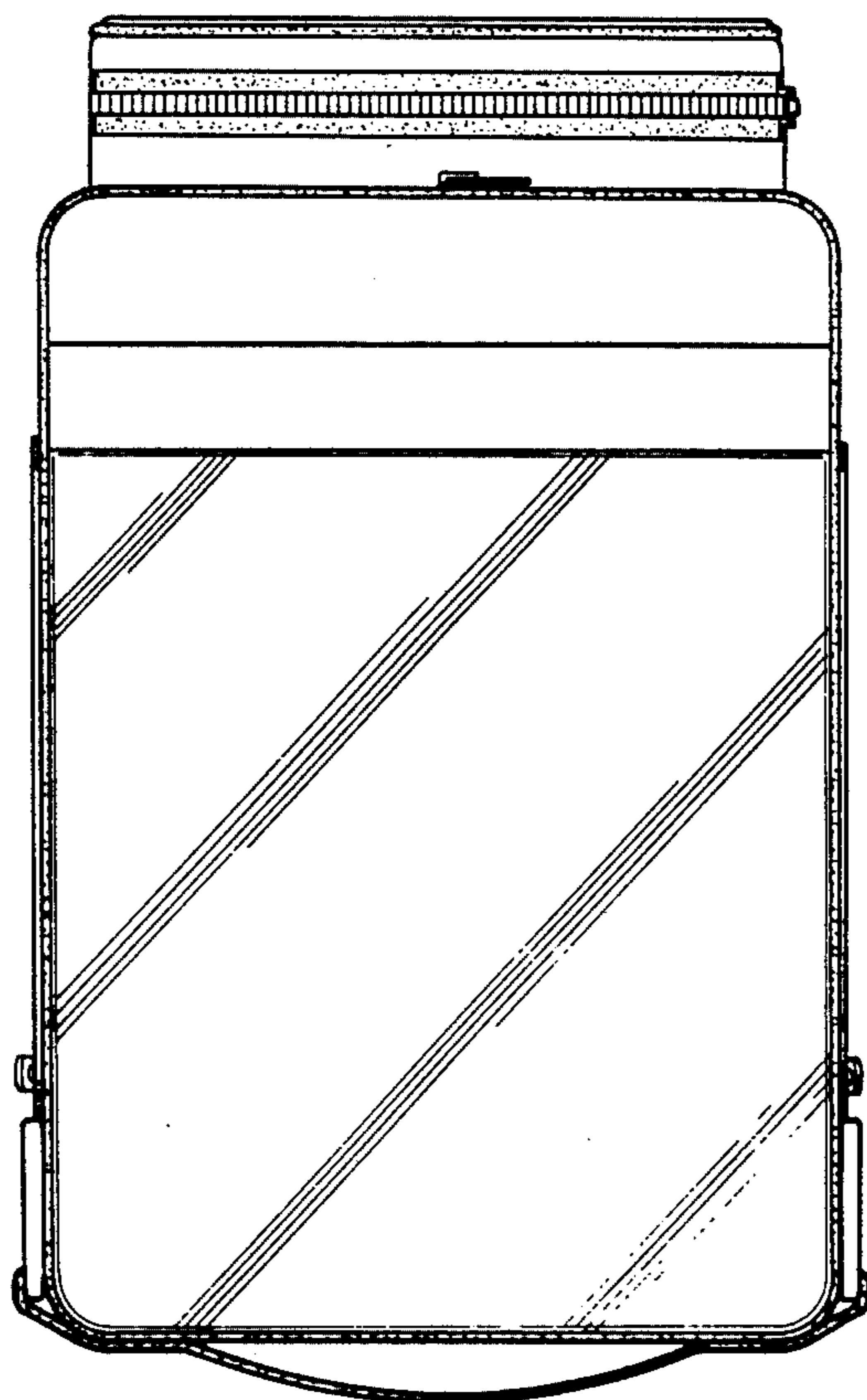

FIG. 2

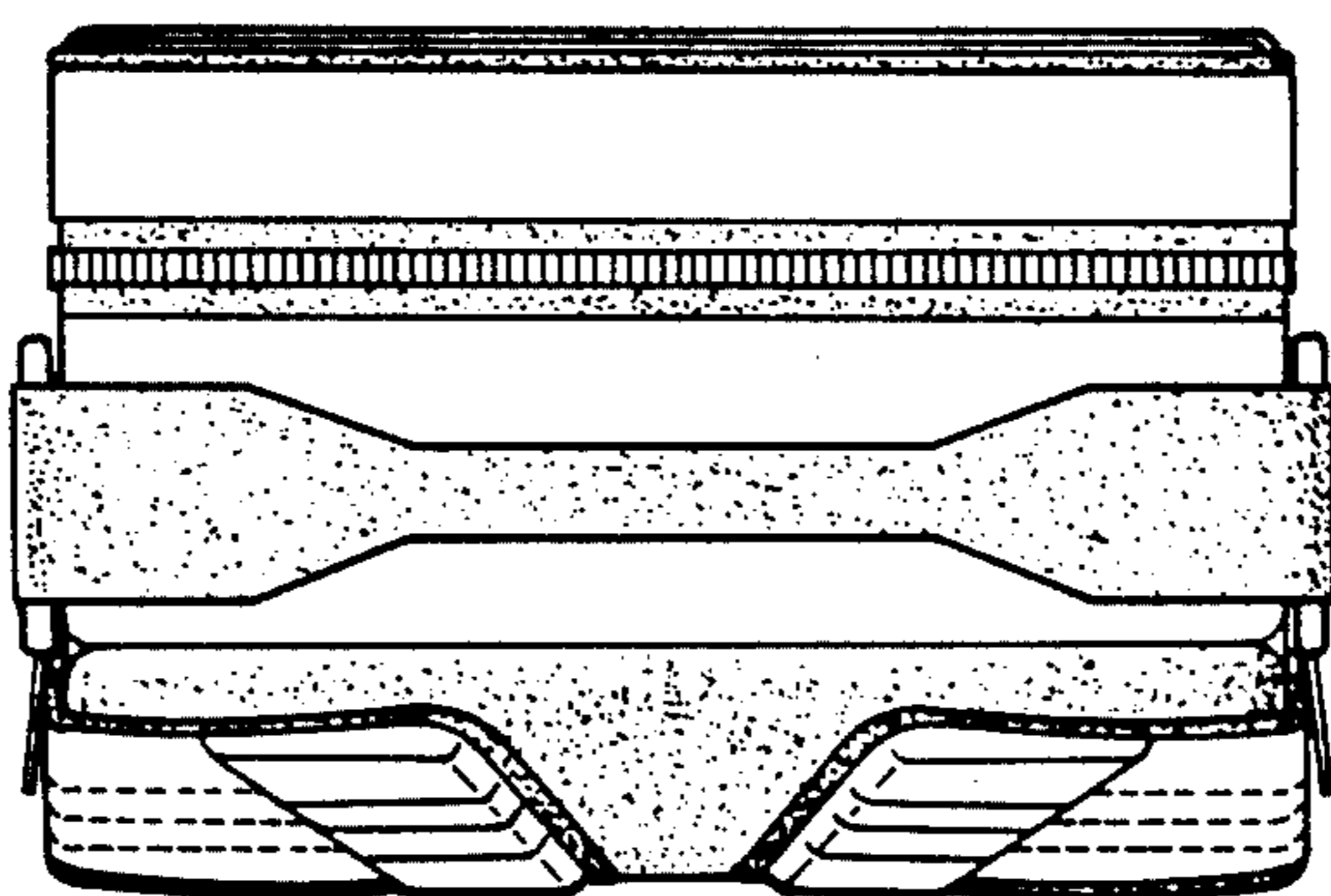

FIG.3

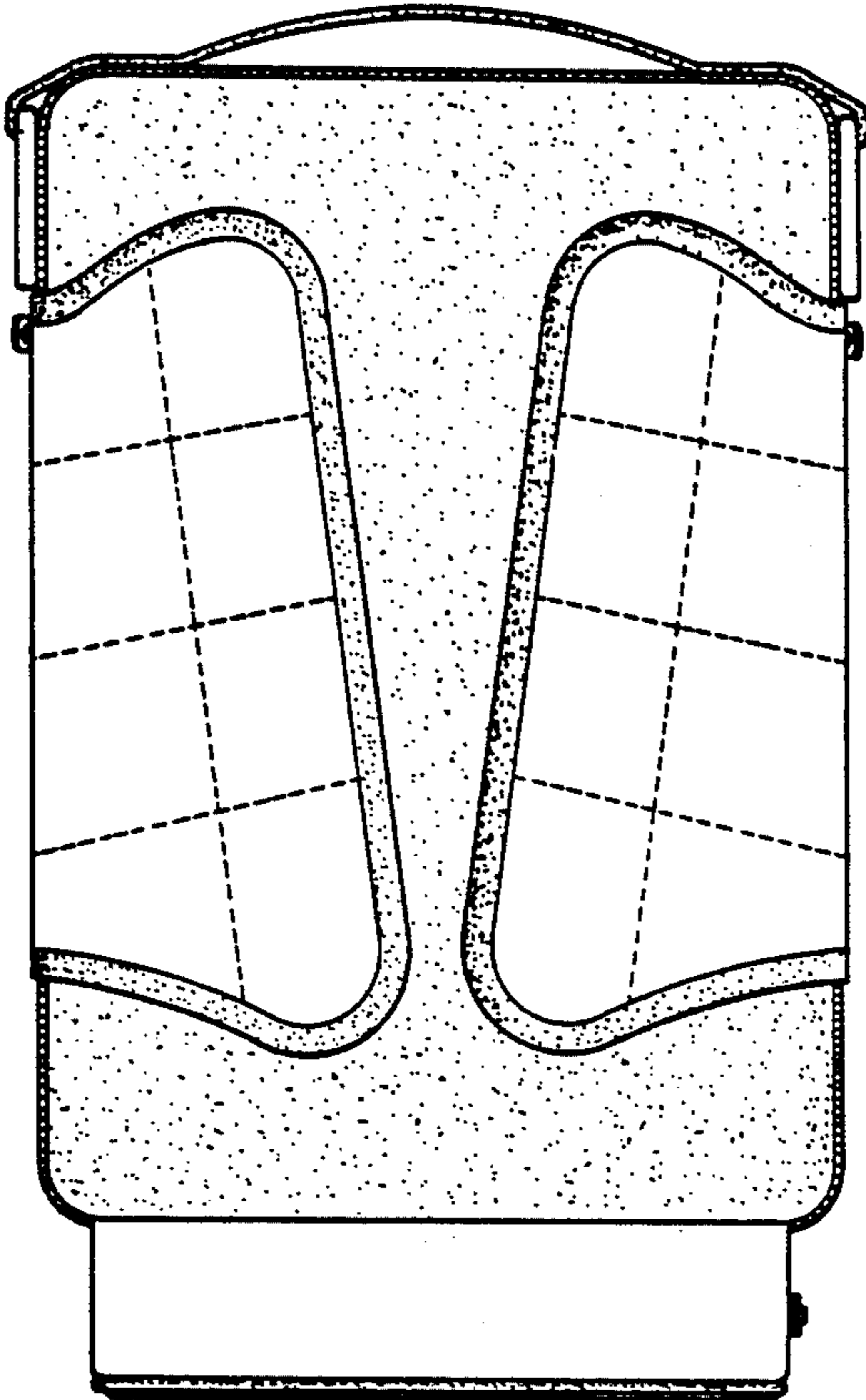

FIG.4

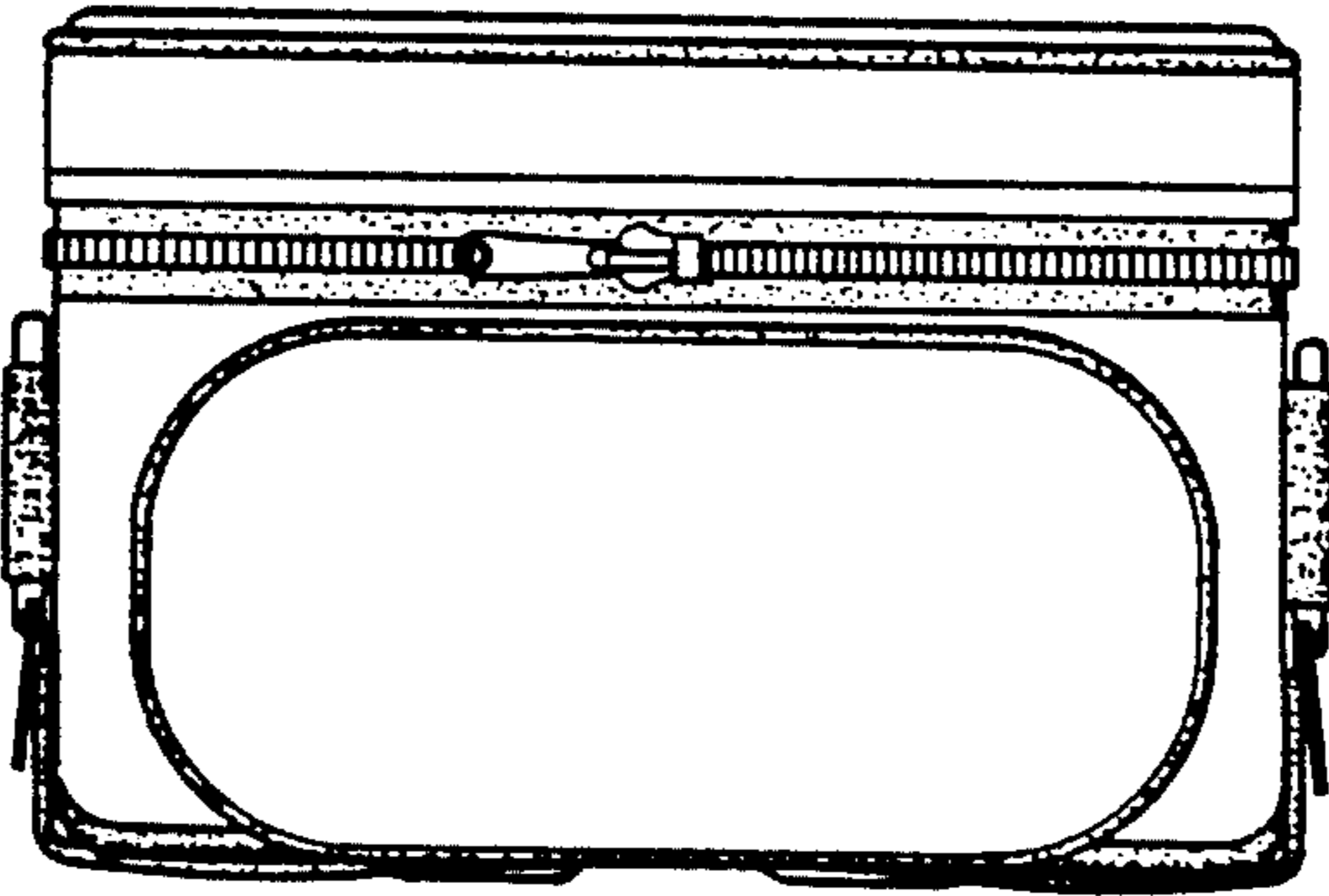

FIG.5

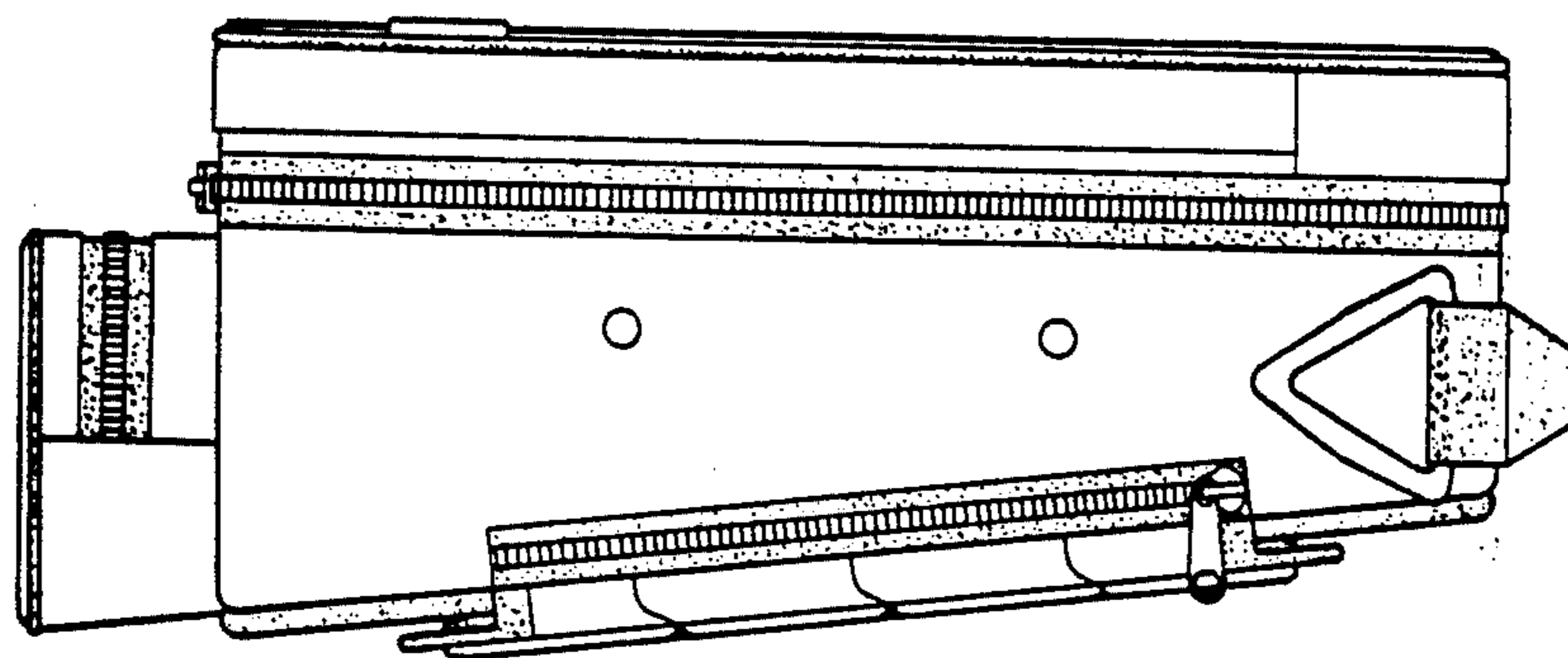

FIG.6

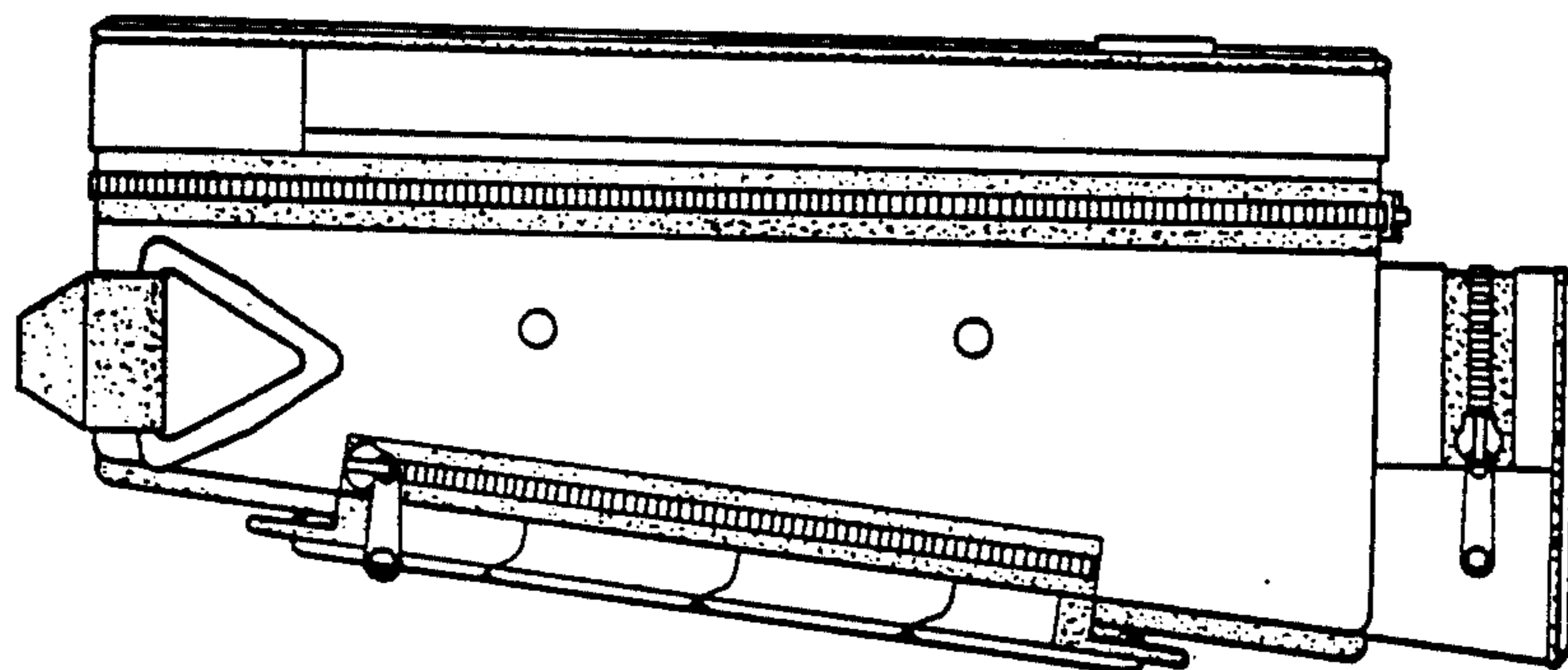

FIG. 7

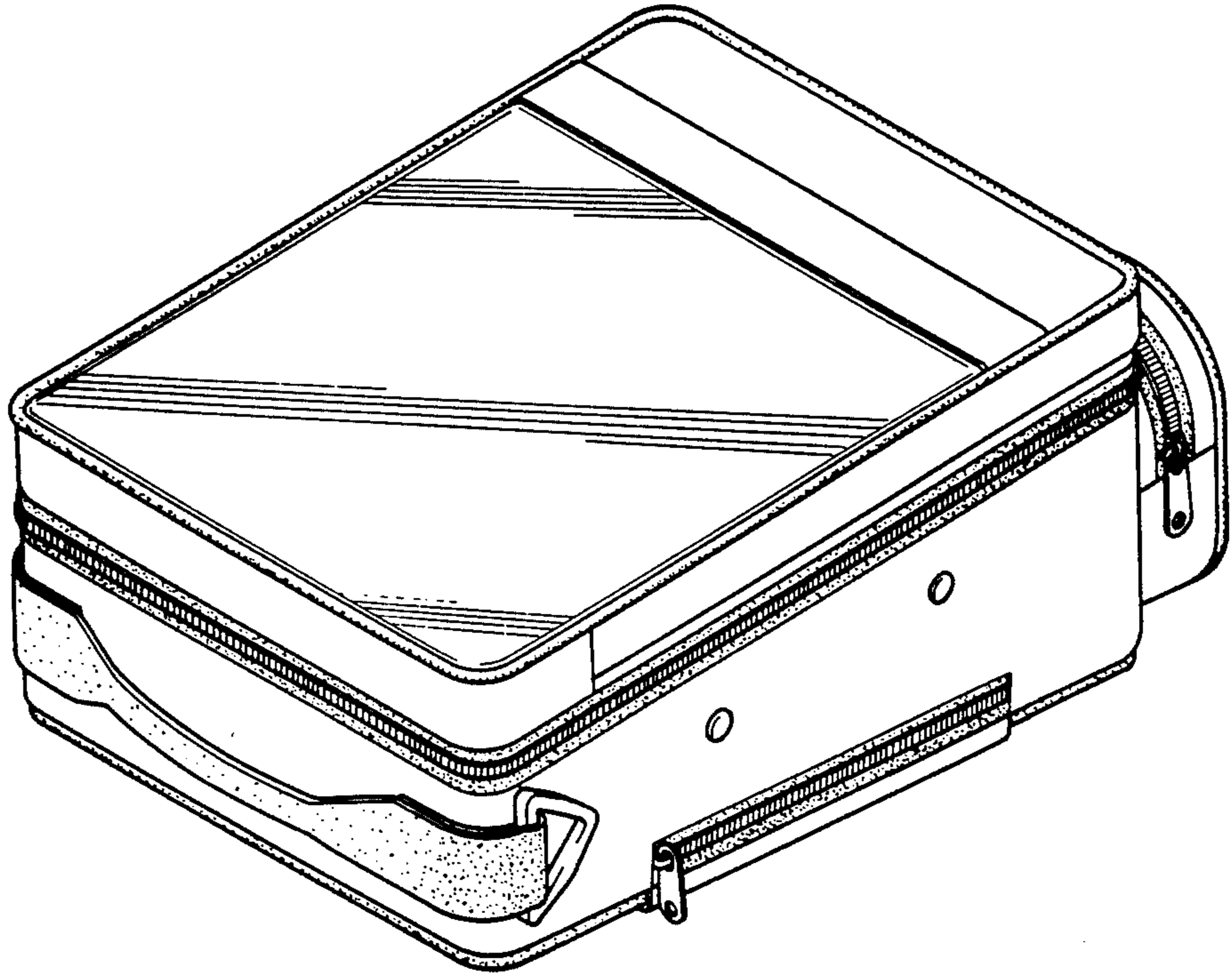

FIG. 8

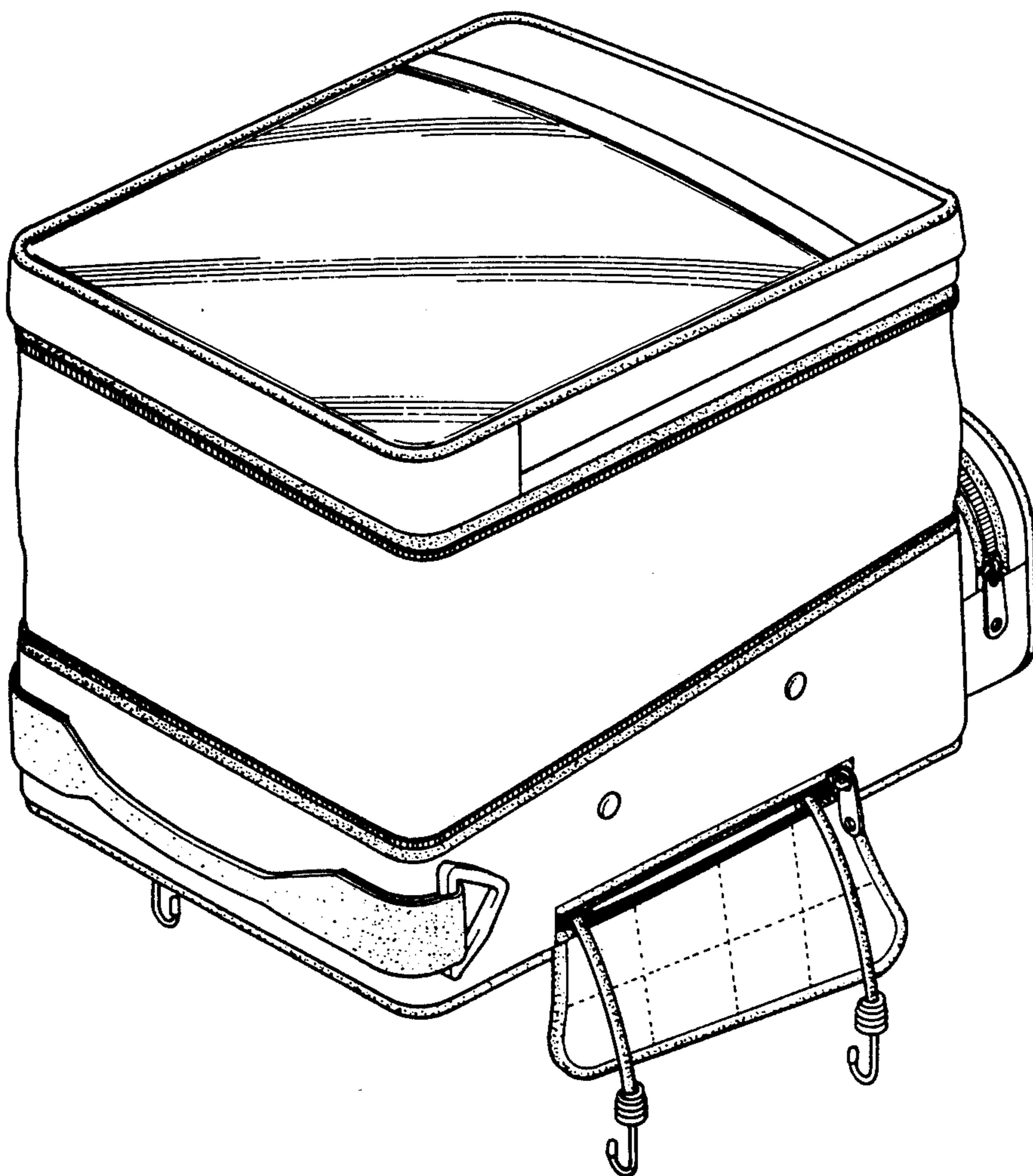

FIG. 9

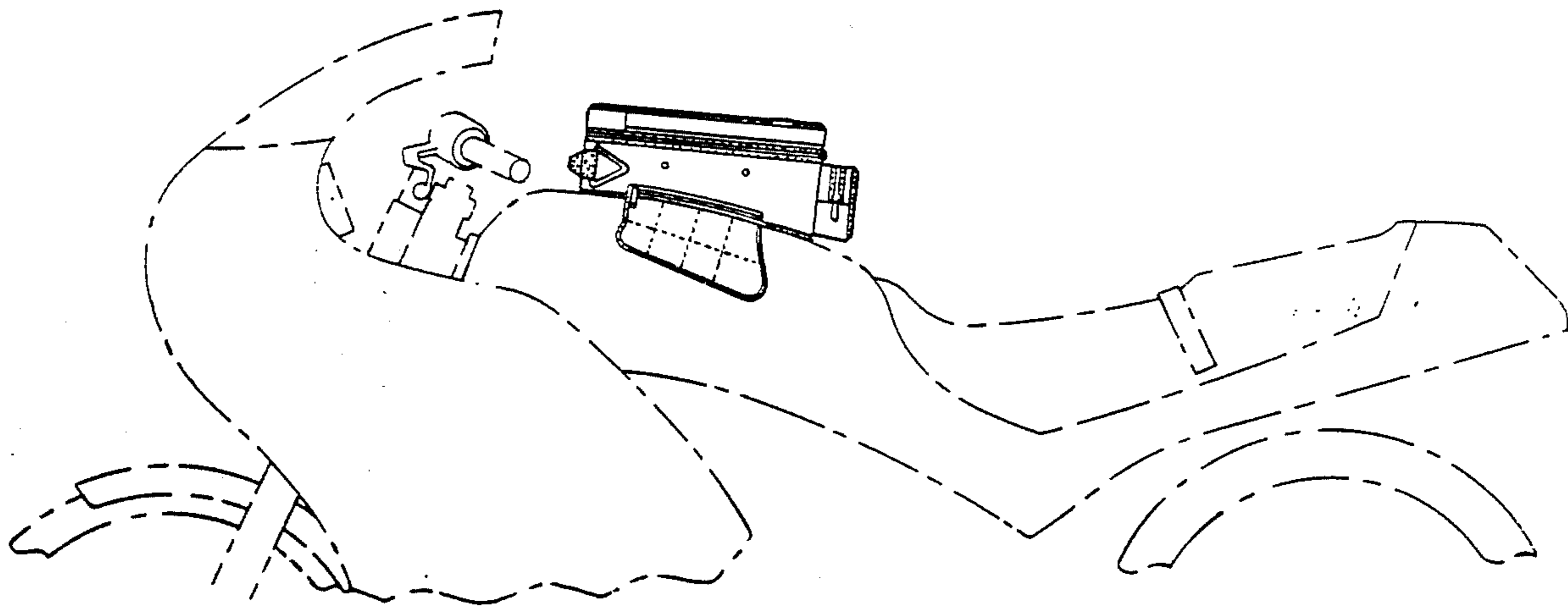

FIG. 10

