

[54] FIRE TRUCK TOY VEHICLE

[75] Inventor: Lawrence R. Harrod, Fort Wayne, Ind.

[73] Assignee: Kransco, San Francisco, Calif.

[**] Term: 14 Years

[21] Appl. No.: 226,215

[22] Filed: Jul. 29, 1988

[52] U.S. Cl. D21/78

[58] Field of Search D21/59, 71, 73-74, D21/76-80, 124, 128, 132-137, 140; 280/1.12, 1.13, 1.21, 1.22, 15, 3, 4, 7.15, 81.01, 87.05, 200, 651, 47.371, 87.021, 828, 655.1; 446/85, 88, 93, 94, 95, 432, 440, 450, 451, 465, 466, 468, 470, 487

[56] References Cited

U.S. PATENT DOCUMENTS

D. 205,529 8/1966 Palmer D21/133

D. 227,282 6/1973 Schreckengost D21/78
D. 281,792 12/1985 Nakao et al. D21/78
D. 289,535 4/1987 Wilkes D21/133
D. 297,034 8/1988 Matsumoto D21/133

Primary Examiner—Charles A. Rademaker
Assistant Examiner—Alicia A. Farrell
Attorney, Agent, or Firm—Kolisch, Hartwell & Dickinson

[57] CLAIM

The ornamental design for a fire truck toy vehicle, as shown.

DESCRIPTION

FIG. 1 is a right side elevational view of a fire truck toy vehicle, showing my new design;
FIG. 2 is a left side elevational view thereof;
FIG. 3 is a top plan view thereof;
FIG. 4 is a bottom plan view thereof;
FIG. 5 is a front elevational view; and,
FIG. 6 is a rear elevational view thereof.

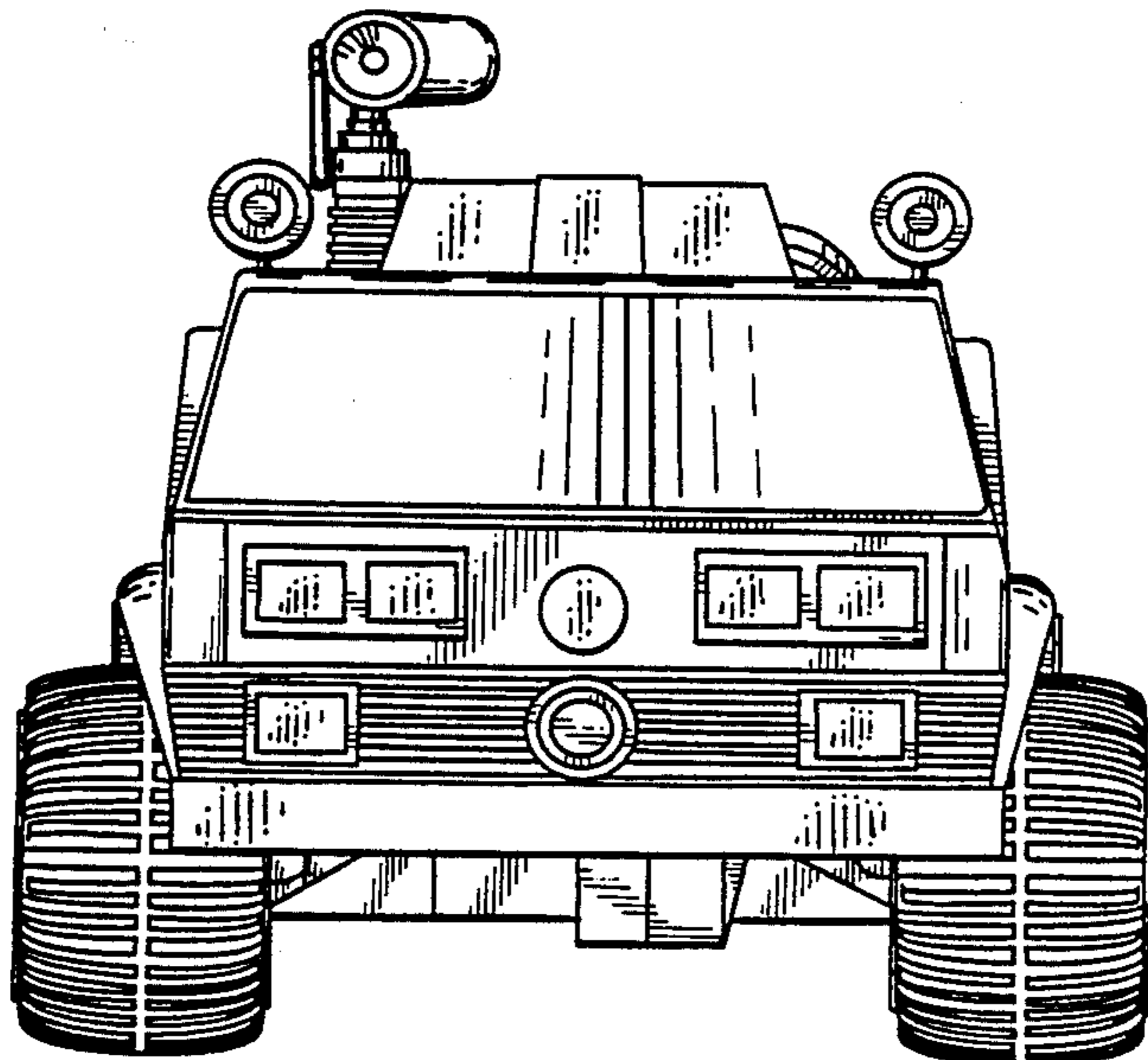
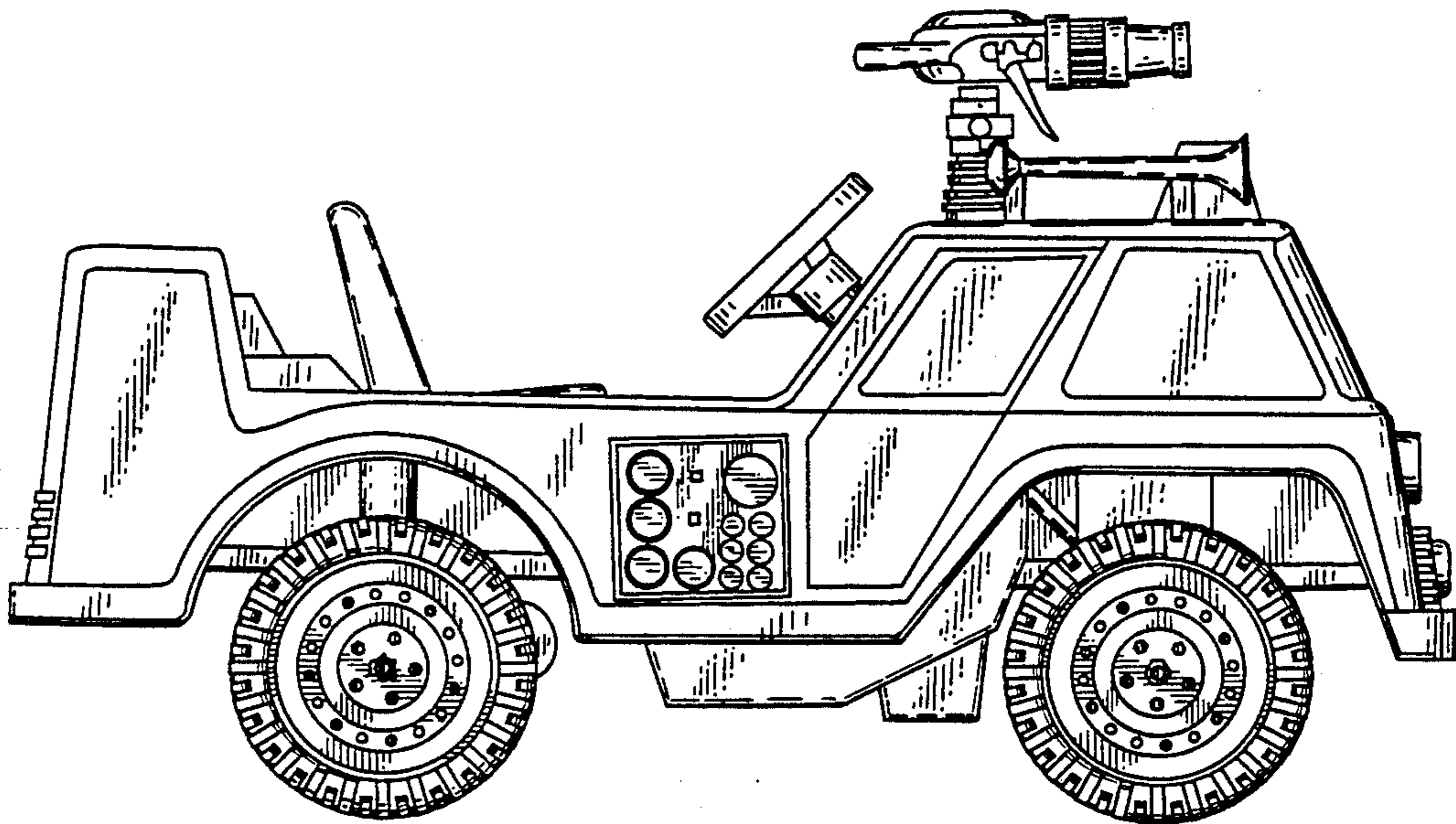

FIG. 1

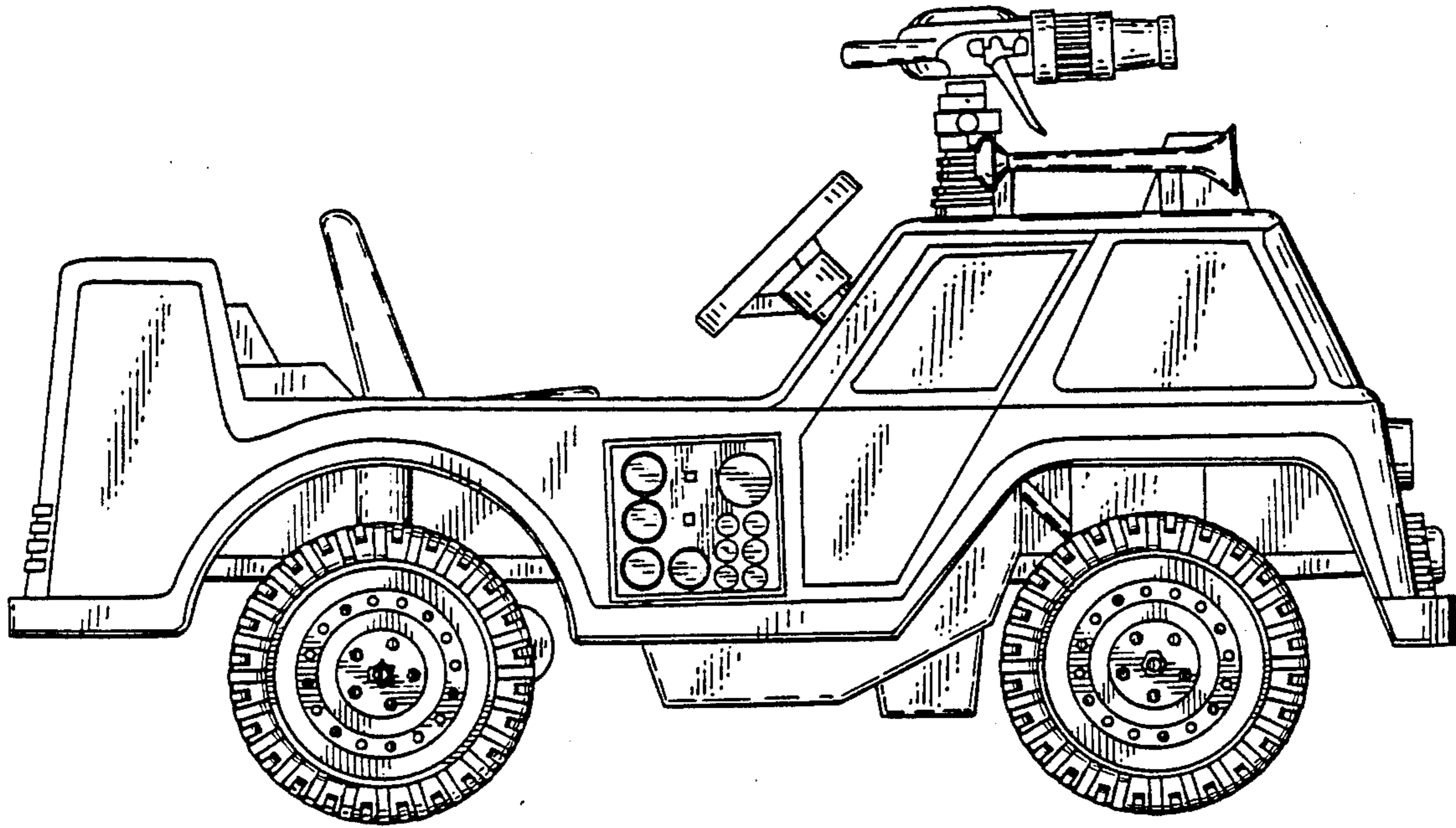

FIG. 2

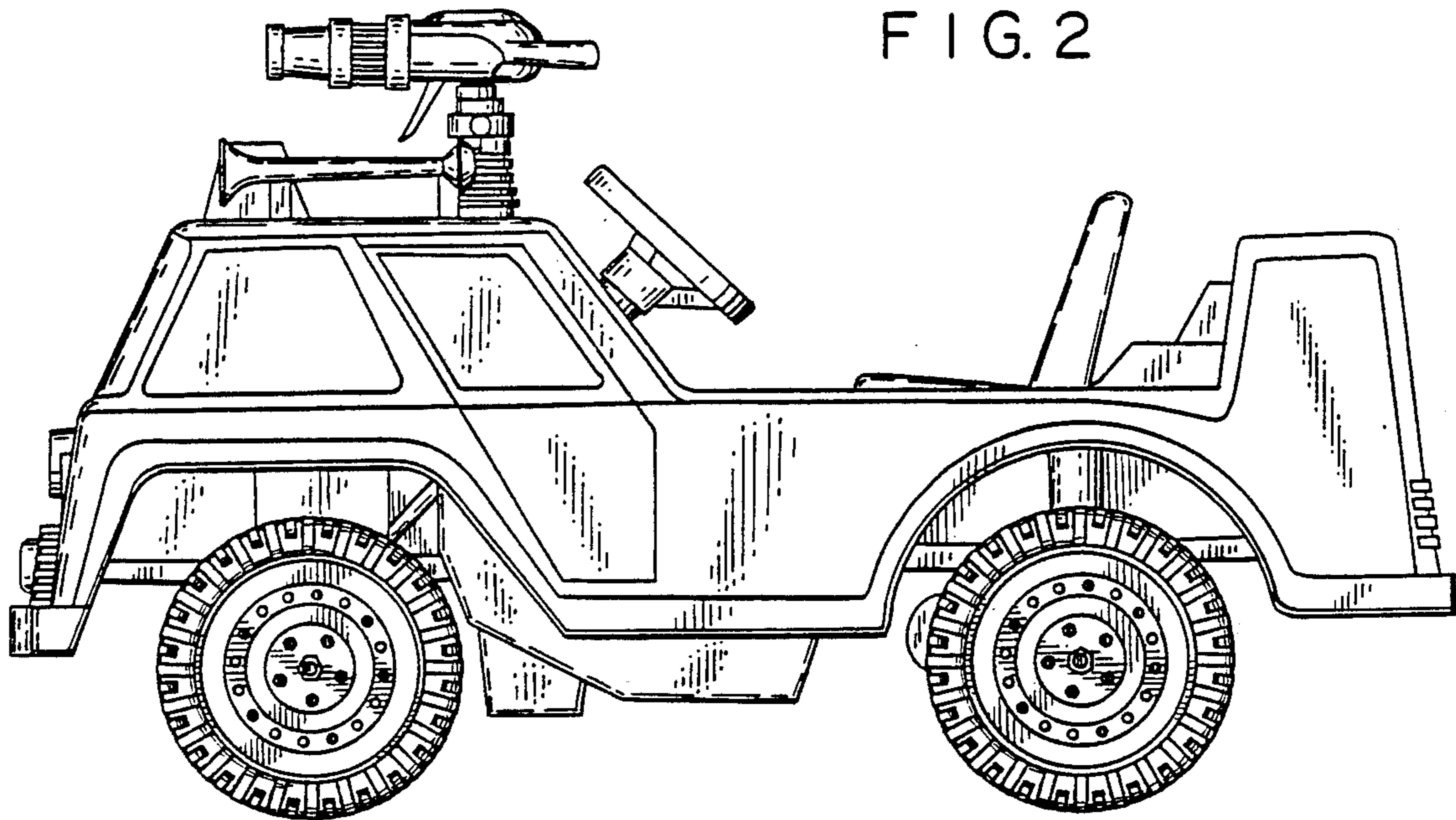

FIG. 3

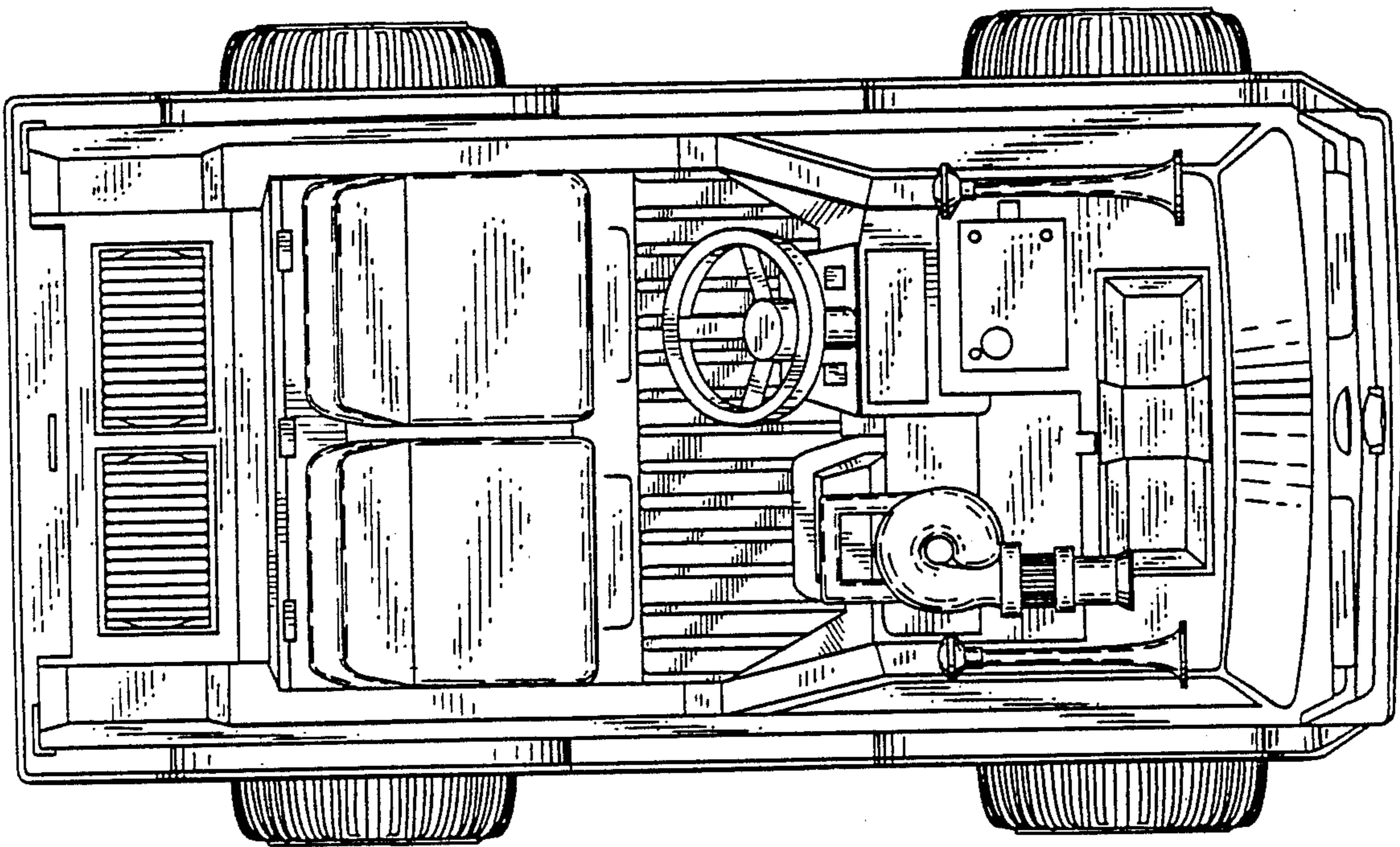

FIG. 4

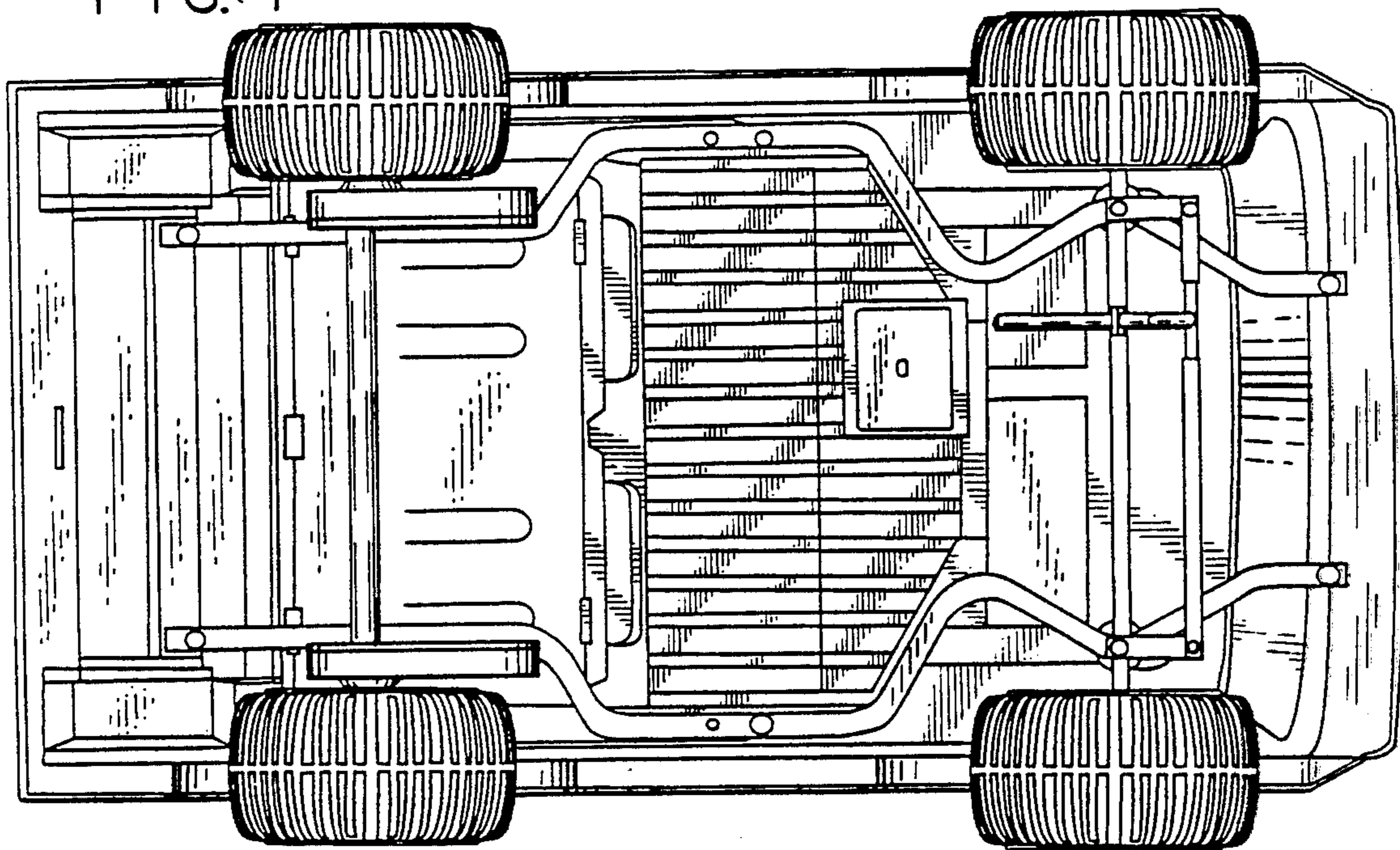

FIG. 5

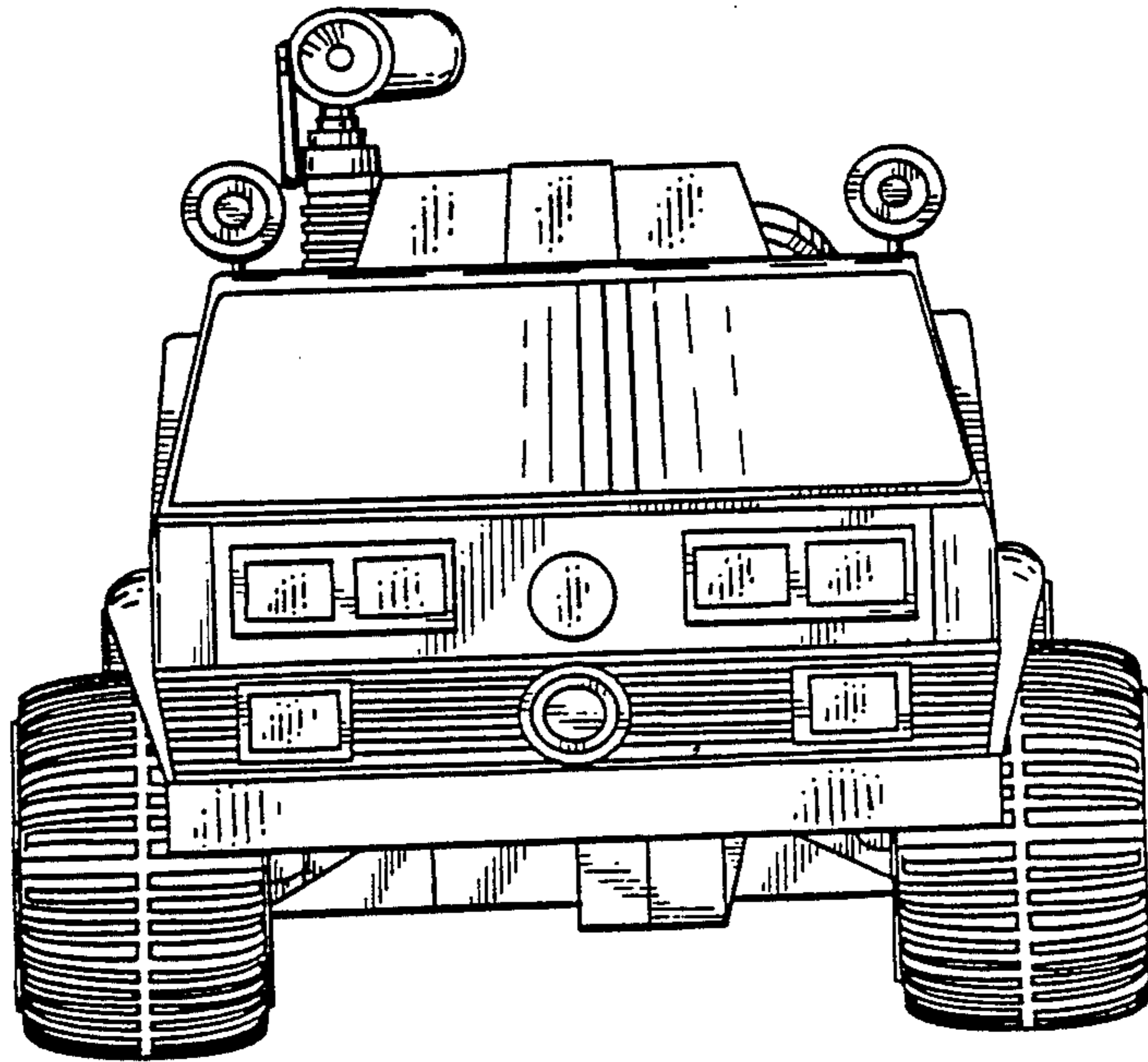

FIG. 6

