

[54] ENGINE OIL FILTER FOR A MOTOR VEHICLE

4,454,037 6/1984 Conterio et al. .... 210/416.5  
4,492,632 1/1985 Mattson ..... D23/209

[76] Inventor: Byoung D. Kim, 649-5,  
Hannam-Dong, Yongsan-Ku, Seoul,  
Rep. of Korea

Primary Examiner—James M. Gandy  
Assistant Examiner—Lisa Lichtenstein  
Attorney, Agent, or Firm—Birch, Stewart, Kolasch &  
Birch

[\*\*] Term: 14 Years

[21] Appl. No.: 35,289

[57] CLAIM

[22] Filed: Apr. 7, 1987

The ornamental design for an engine oil filter for a motor vehicle, as shown and described.

[52] U.S. Cl. .... D23/209

[58] Field of Search ..... D23/200, 207, 209;  
210/416.5

DESCRIPTION

[56] References Cited

U.S. PATENT DOCUMENTS

- D. 149,380 4/1948 Schaefer ..... D23/209
- D. 219,103 11/1970 Dexter ..... D23/209
- D. 250,124 10/1978 Glaspie et al. .... D23/209
- 2,936,891 5/1960 Kukowski et al. .... D23/209

FIG. 1 is a top plan view of the engine oil filter for a motor vehicle showing my new design;  
FIG. 2 is a bottom plan view thereof;  
FIG. 3 is a front elevational view thereof, it being understood that the opposite side is a mirror image of that shown;  
FIG. 4 is a perspective view thereof; and  
FIG. 5 is a cross-sectional view of FIG. 4.

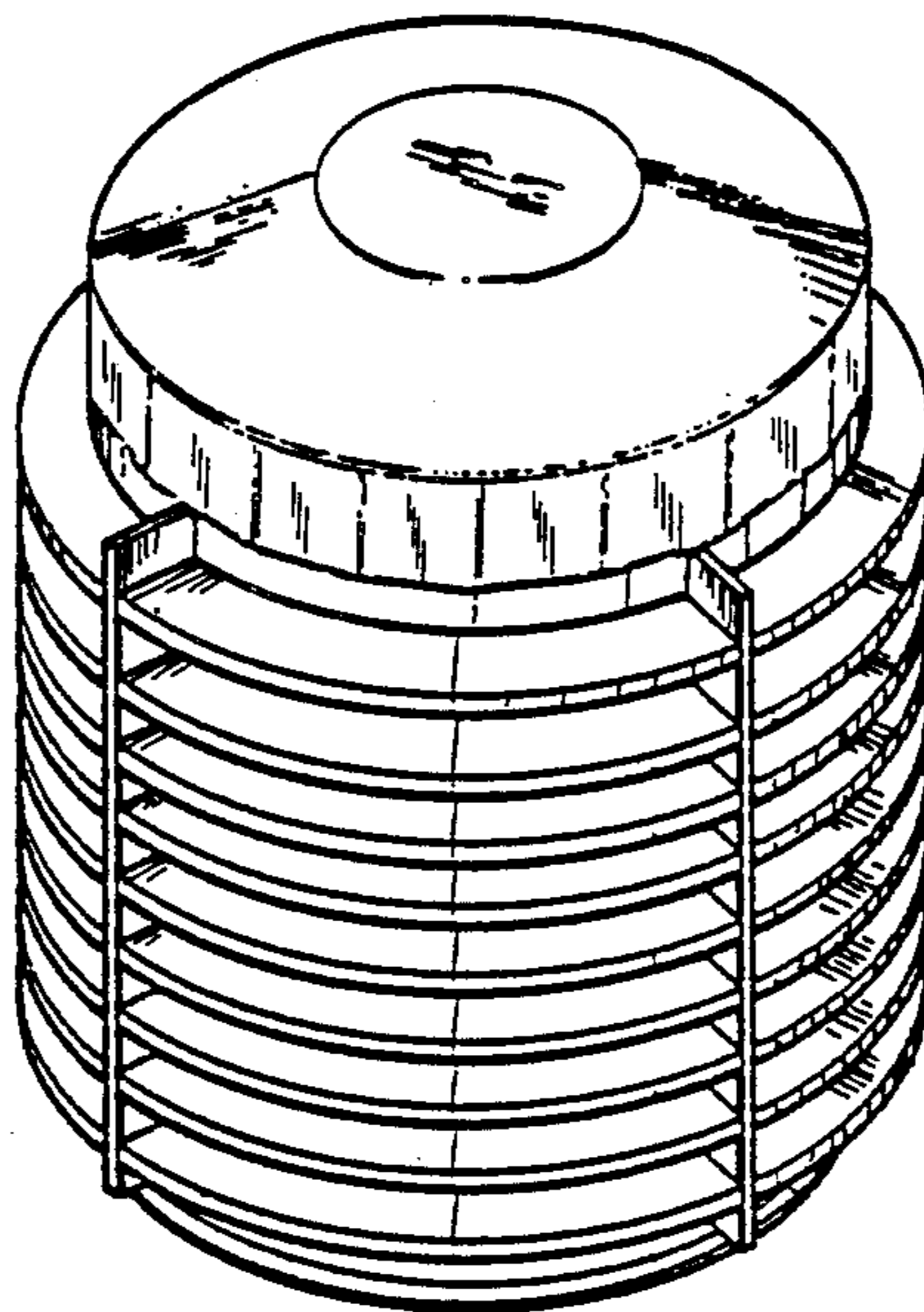

FIG. 1

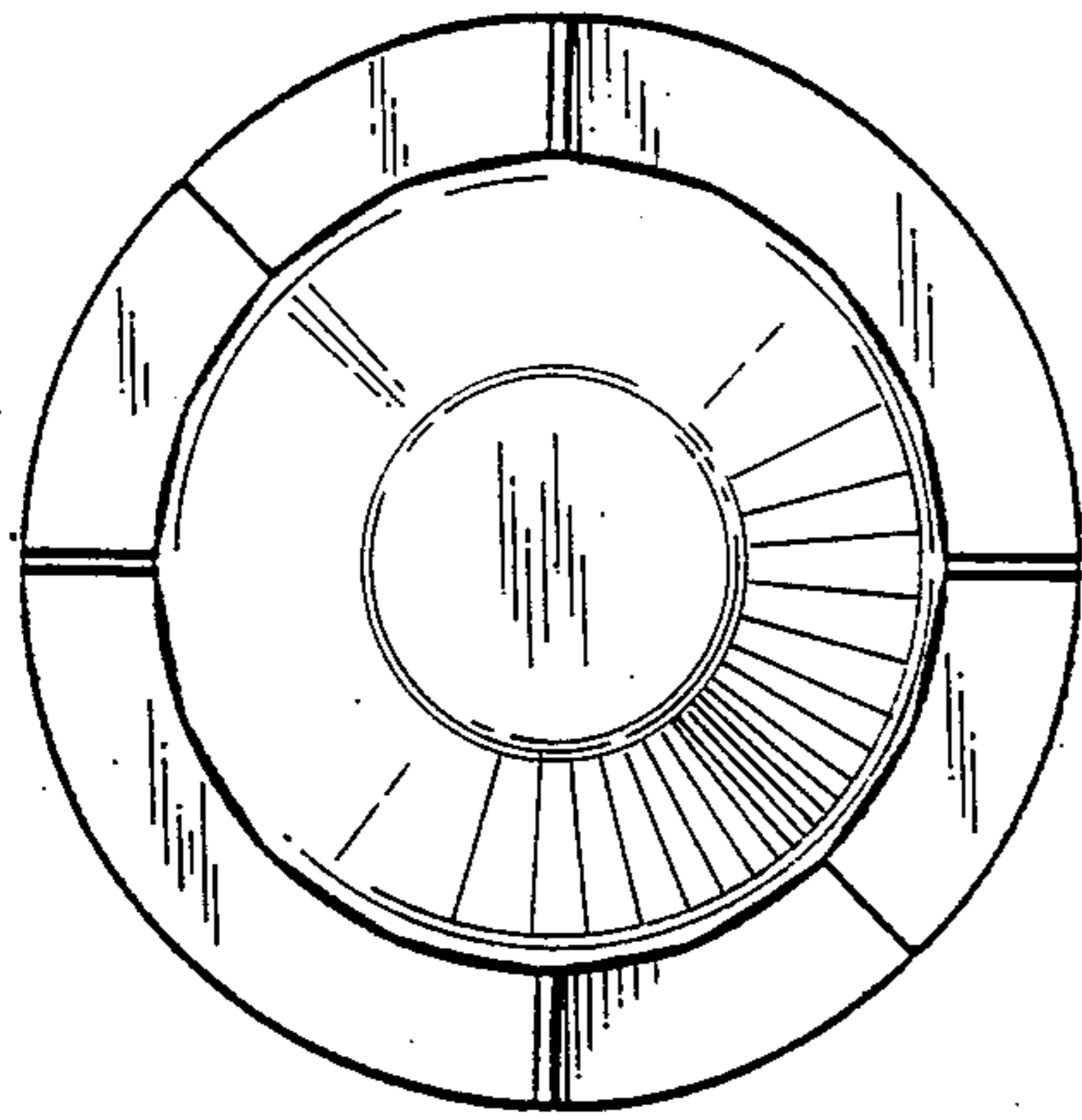

FIG. 2

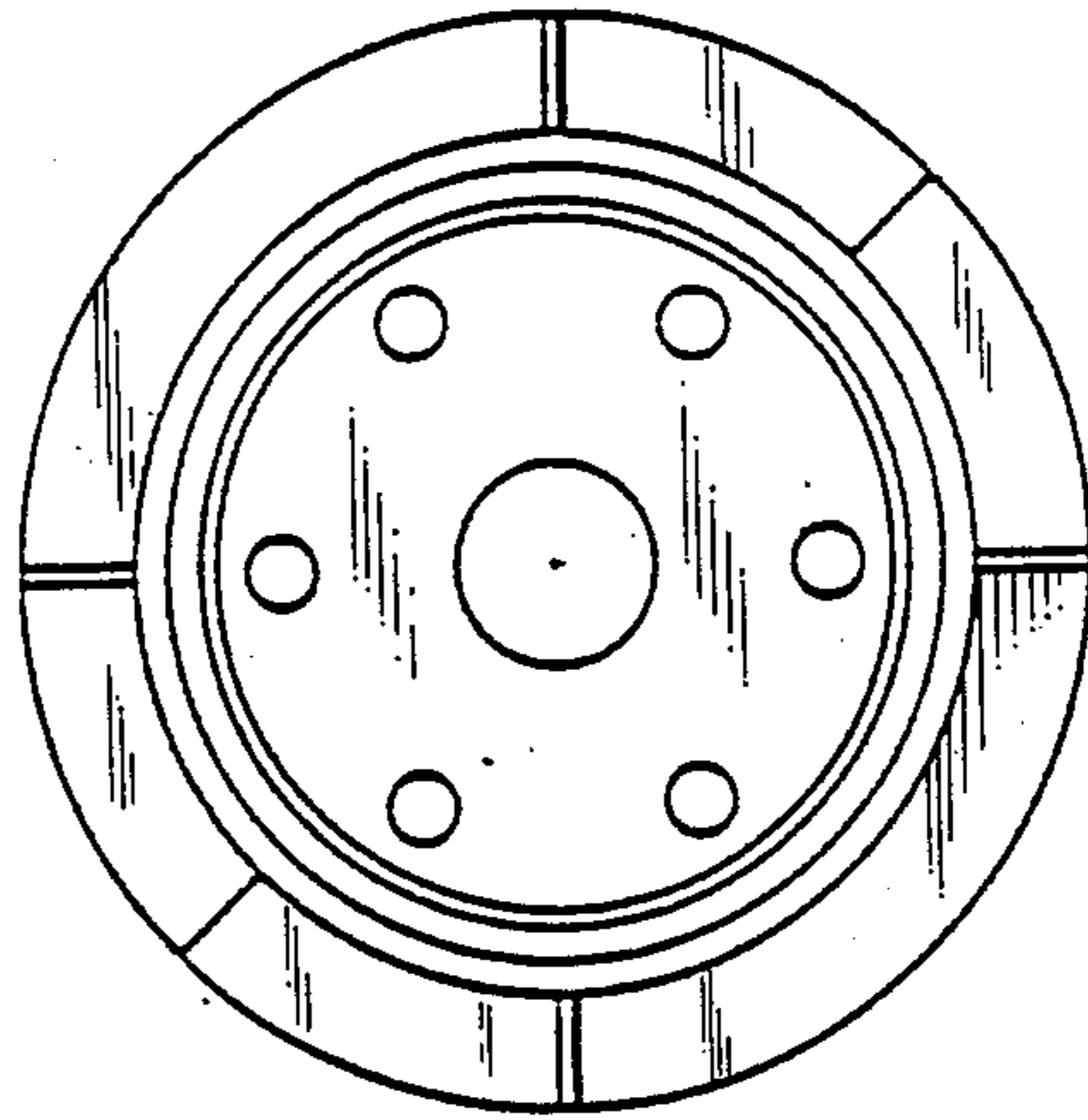

FIG. 3

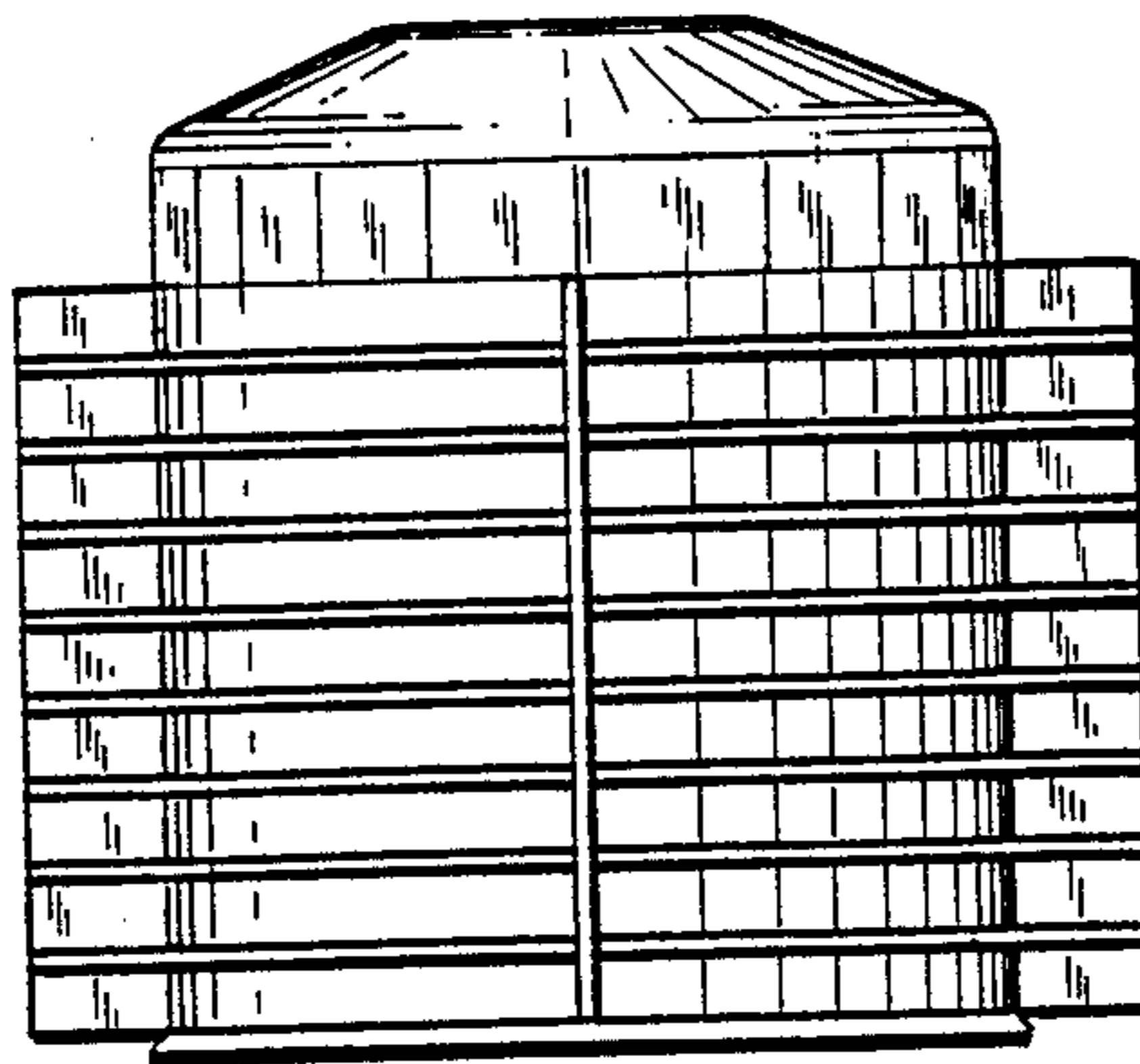

FIG. 4

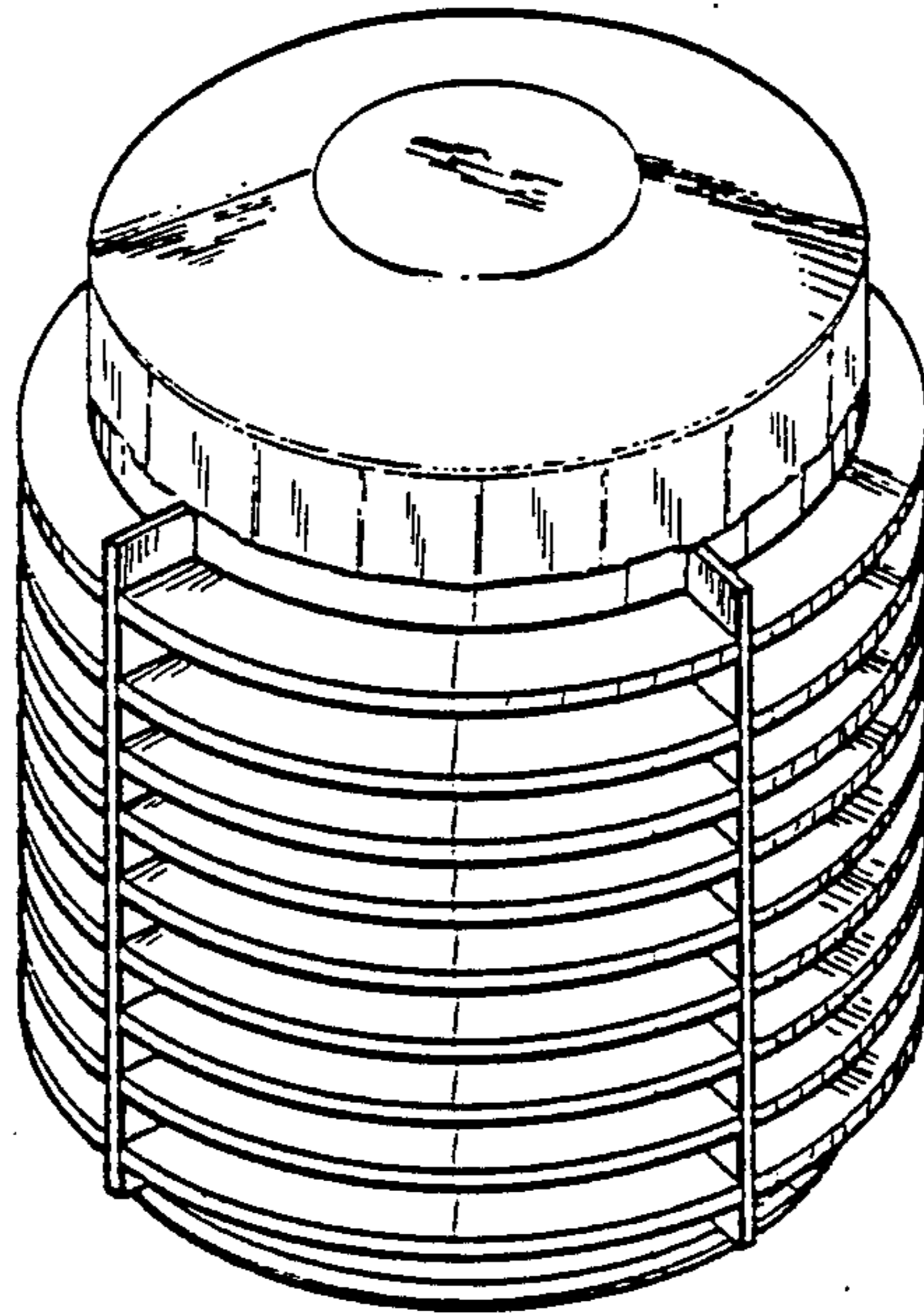

FIG. 5

