

[54] PARTIAL SEAT COVER FOR USE IN VEHICLES

[75] Inventors: Bob Bailey, Ballston Lake; Jeffrey L. Stucker, Salem, both of N.Y.

[73] Assignee: Racemark International, Inc., Ballston Spa, N.Y. ; a part interest

[**] Term: 14 Years

[21] Appl. No.: 236,111

[22] Filed: Aug. 23, 1988

[52] U.S. Cl. D6/611

[58] Field of Search D6/356, 500, 610, 611; 297/218, 223, 225, 229

J. C. Whitney Co., ©1983, p. 73, Seat Covers, top center and center right of page.

J. C. Whitney Co., ©1983, p. 75, Seat Covers, top center and center right of page.

The Variable-Control Heated Car Seat Cover. Custom BMW Sheepskin Seatcovers, BMW of North America, Inc., Montvale, NJ 07645.

Merino Makes the Difference, Saab-Scania of America, Inc., Saab Drive, Orange, CT 06477.

Primary Examiner—Nelson C. Holtje

Assistant Examiner—Ann Hunt

Attorney, Agent, or Firm—Heslin & Rothenberg

[57] CLAIM

The ornamental design for partial seat cover for use in vehicles, as shown and described.

DESCRIPTION

FIG. 1 is a front elevational view of the partial seat cover for use in vehicles showing our new design, the automobile seat shown in broken lines is for illustrative purposes only and forms no part of the claimed design; FIG. 2 is a perspective view, the automobile seat shown in broken lines is for illustrative purposes only and forms no part of the claimed design;

FIG. 3 is a front perspective view;

FIG. 4 is a rear perspective view thereof;

FIG. 5 is a front perspective view of a second embodiment;

FIG. 6 is a rear perspective view thereof;

FIG. 7 is a front perspective view of a third embodiment; and

FIG. 8 is a rear perspective view thereof.

[56] References Cited

U.S. PATENT DOCUMENTS

D. 267,523	1/1983	Neilson	D6/500
4,320,922	3/1982	Meritis	297/229
4,383,712	5/1983	Kaganas	297/219
4,396,227	8/1983	Neilson	297/219
4,457,032	7/1984	Clarke	5/481
4,669,779	6/1987	Kaganas et al.	297/229
4,676,376	6/1987	Keiswetter	297/229
4,676,549	6/1987	English	297/229
4,772,070	9/1988	Leto, Jr. et al.	297/218
4,790,592	12/1988	Busso et al.	297/218

OTHER PUBLICATIONS

J. C. Whitney Co., ©1983, p. 0, Seat Cushions, top center of page.

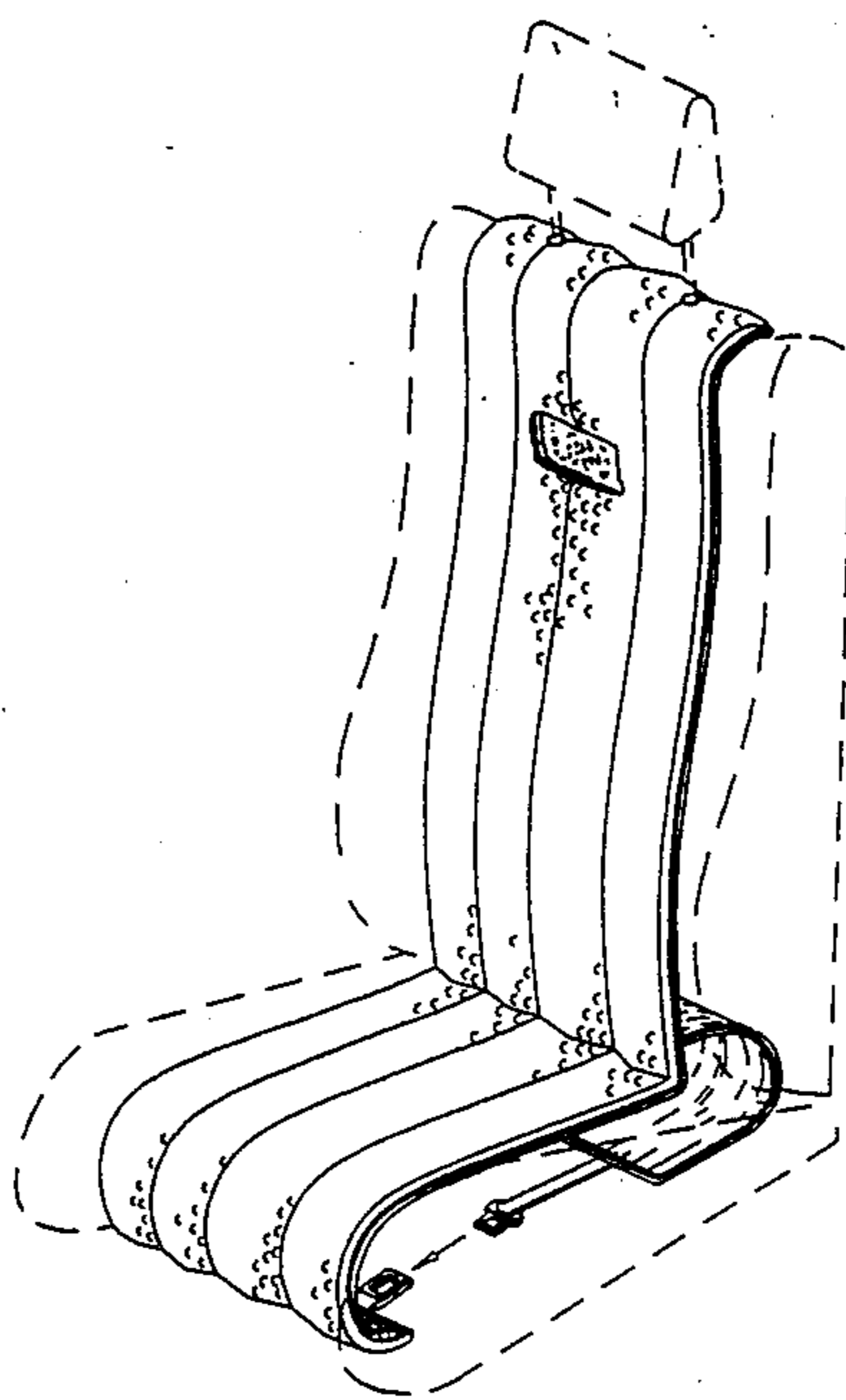

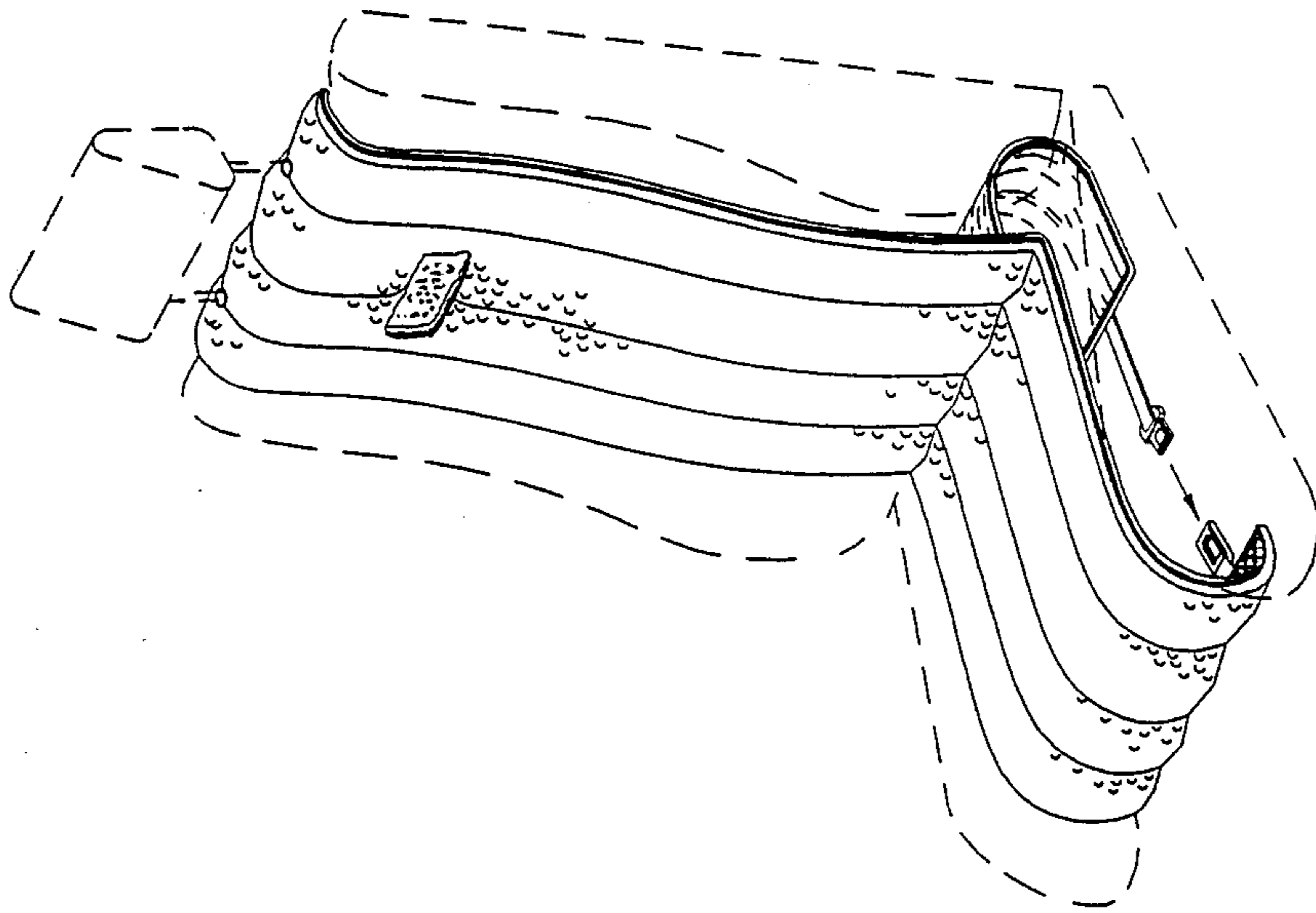

FIG. 2

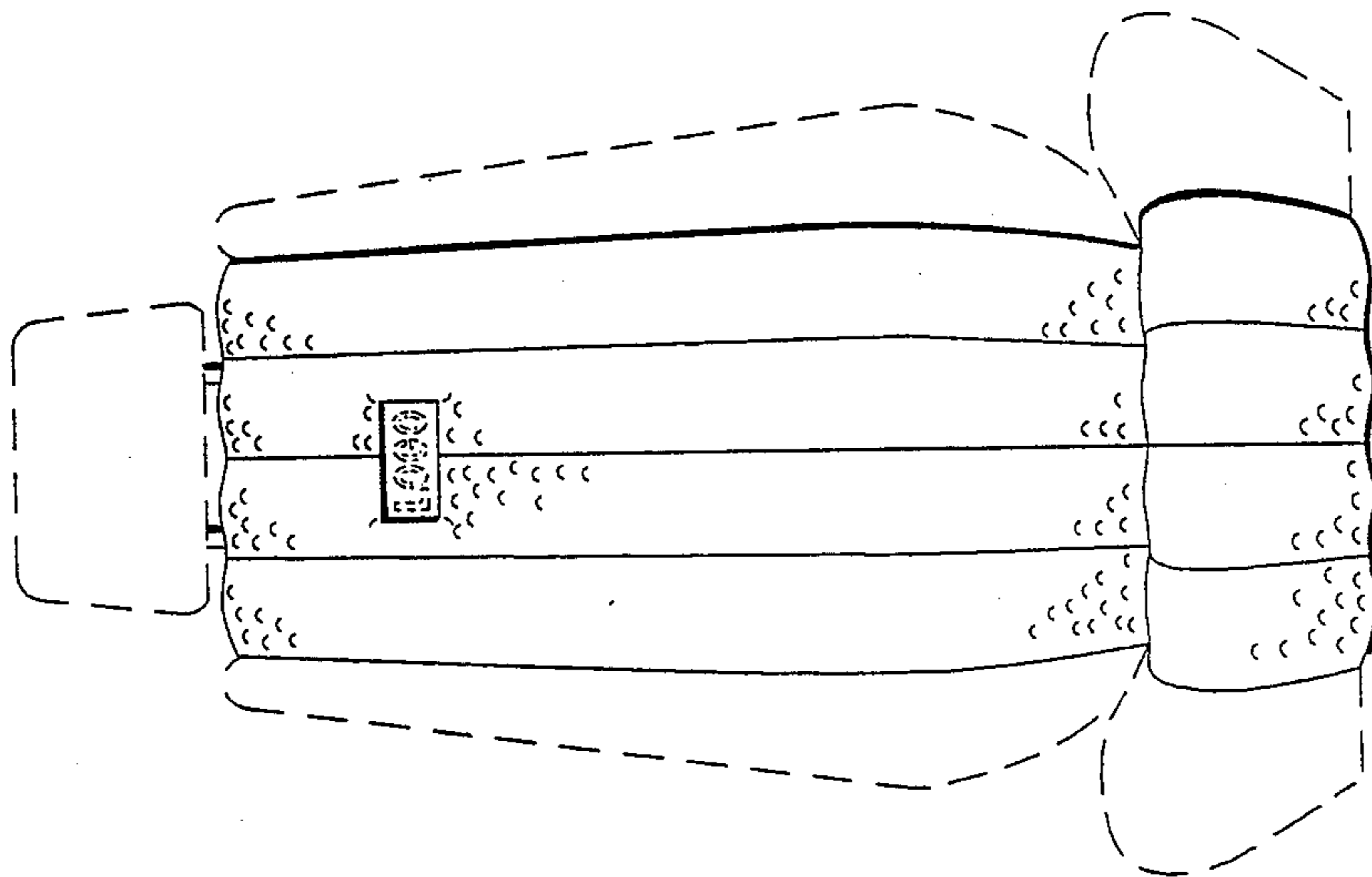

FIG. 1

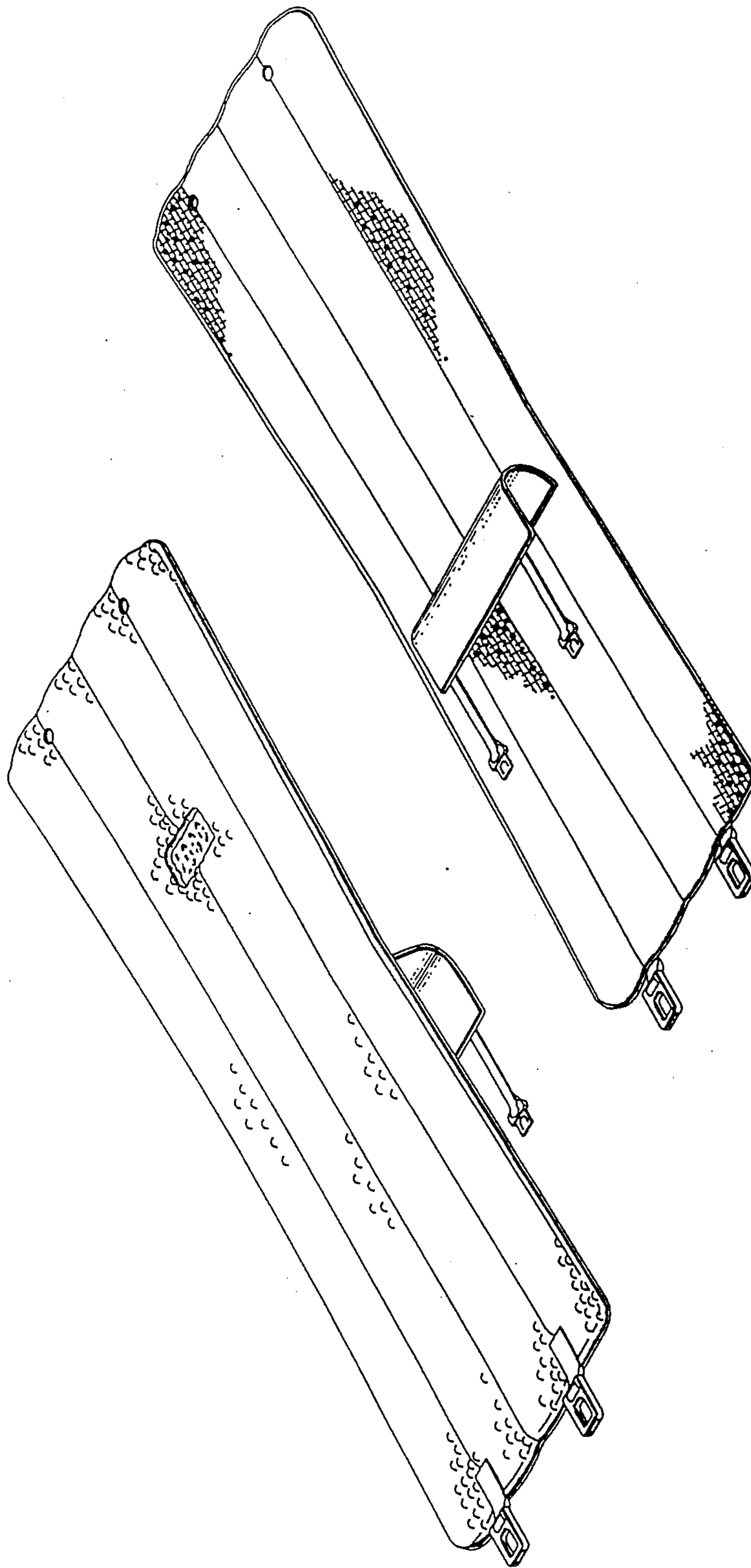

FIG. 3

FIG. 4

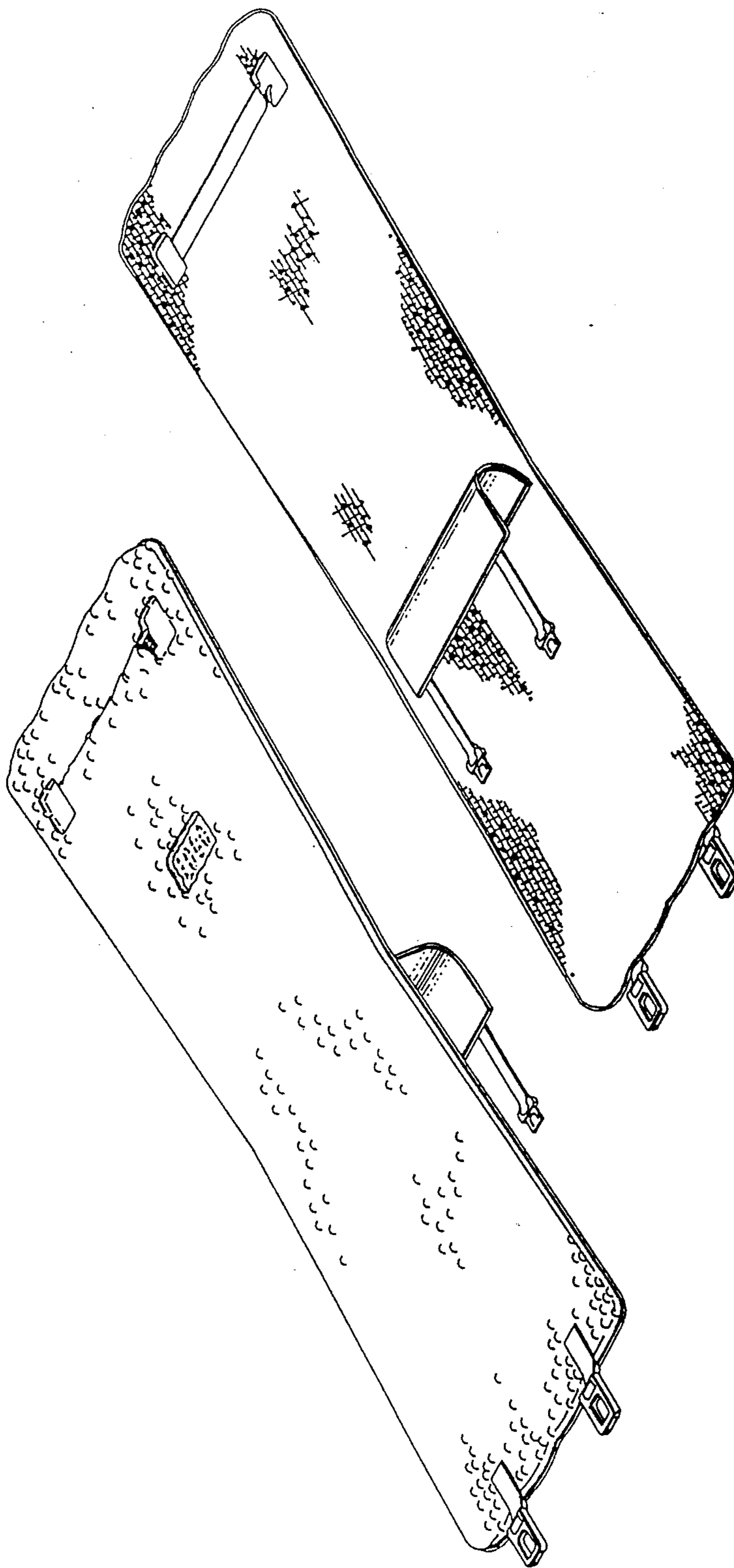

FIG. 6

FIG. 5

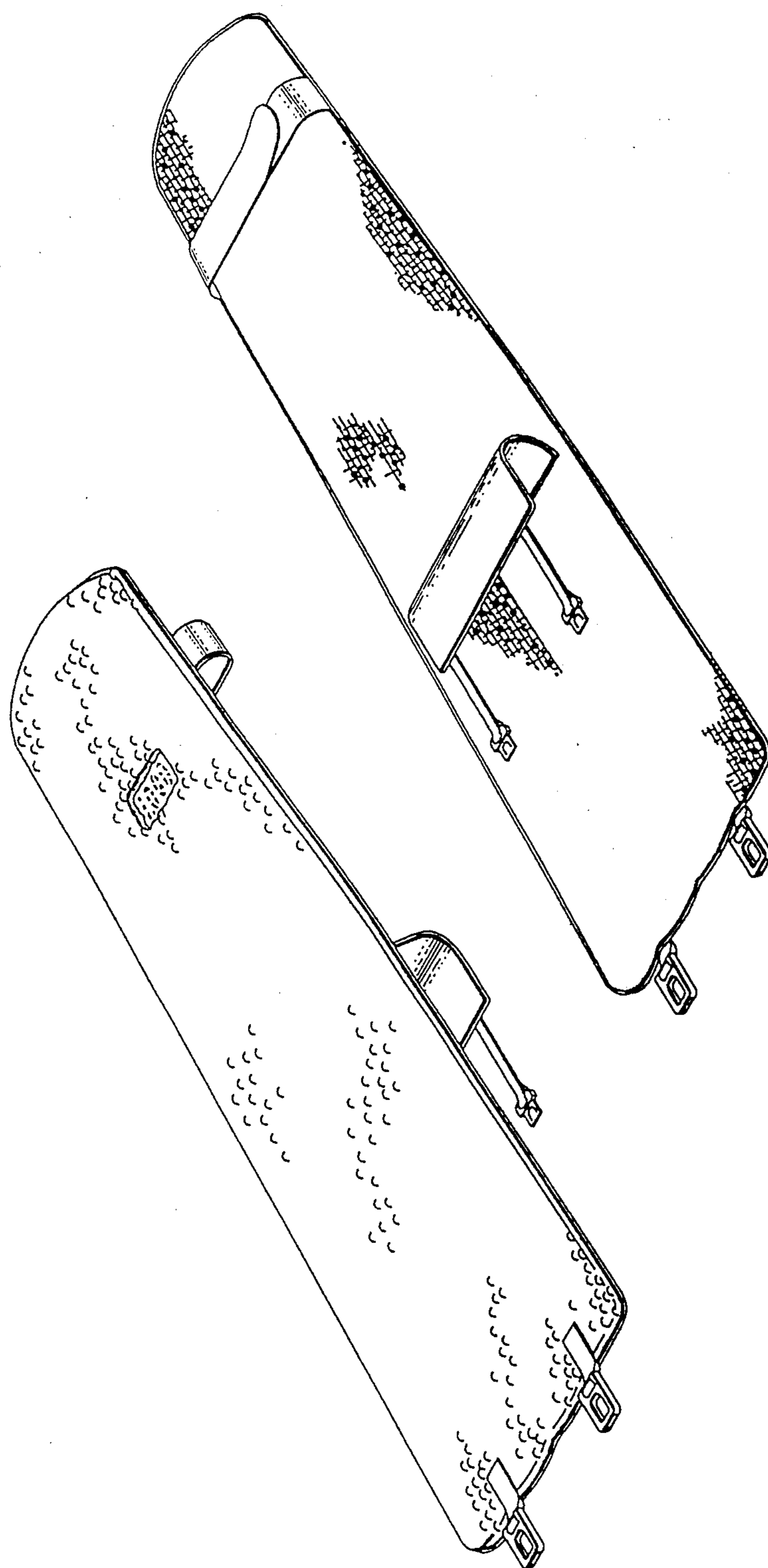

FIG. 8

FIG. 7