

[54] VEHICLE LIFT

4,558,648 12/1985 Franklin et al. 248/588
4,577,821 3/1986 Edmo et al. 187/18
4,724,930 2/1988 VanLierop 187/8.43

[75] Inventor: Yusuke Kawana, Otowa, Japan

[73] Assignee: Sugiyasu Industries Co., Ltd.,
Takahama, Japan

[**] Term: 14 Years

[21] Appl. No.: 151,268

[22] Filed: Feb. 2, 1988

[30] Foreign Application Priority Data

Dec. 3, 1987 [JP] Japan 62-49673

[52] U.S. Cl. D34/31

[58] Field of Search D34/28, 31; 254/9 C,
254/9 B, 122, 2 B, 90; 187/18, 8.43; 248/588,
421

[56] References Cited

U.S. PATENT DOCUMENTS

3,110,476 11/1963 Farris 254/122
4,180,252 12/1979 Cushenbery 254/9 B

Primary Examiner—James M. Gandy
Assistant Examiner—Kay H. Chin
Attorney, Agent, or Firm—Lahive & Cockfield

[57] CLAIM

The ornamental design for a vehicle lift, as shown and described.

DESCRIPTION

FIG. 1 is a top and left side perspective view of a vehicle lift showing my new design;
FIG. 2 is a left side elevational view thereof;
FIG. 3 is a right side elevational view thereof;
FIG. 4 is a top plan view thereof.
FIG. 5 is a bottom plan view thereof.
FIG. 6 is a rear elevational view thereof.
FIG. 7 is a front elevational view thereof.
FIG. 8 is a front elevational view thereof, showing the vehicle lift in folded condition.

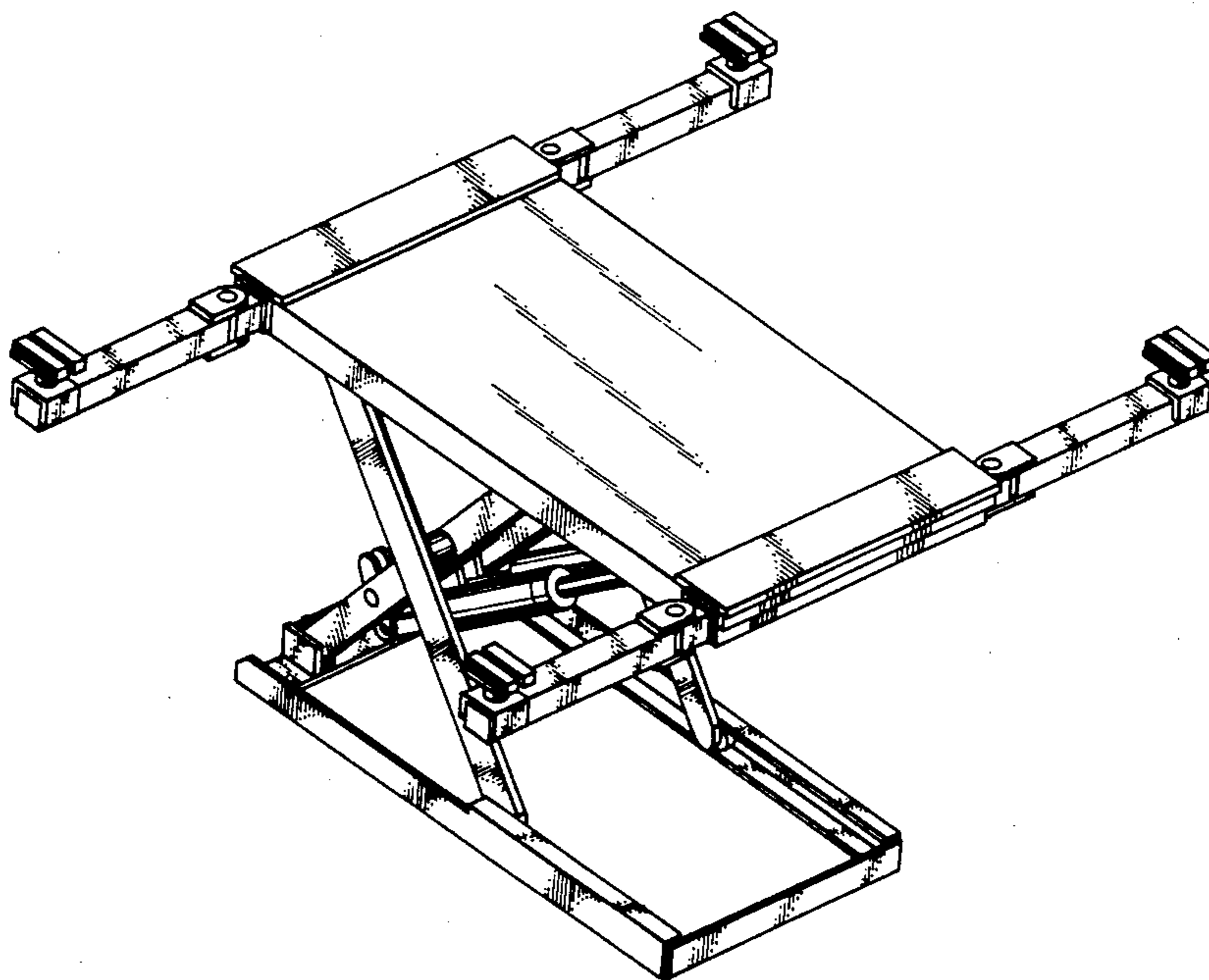

FIG. 1

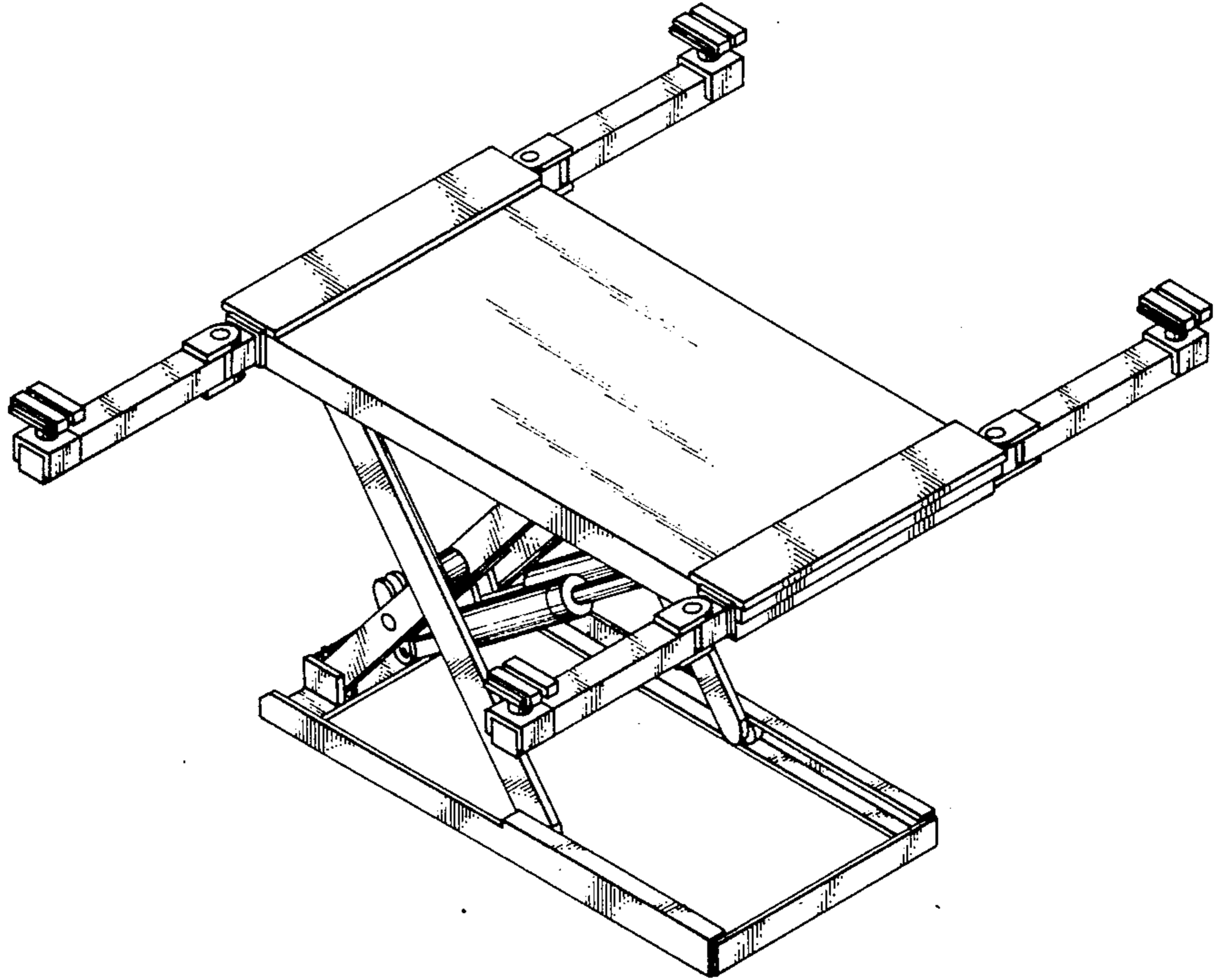

FIG. 2

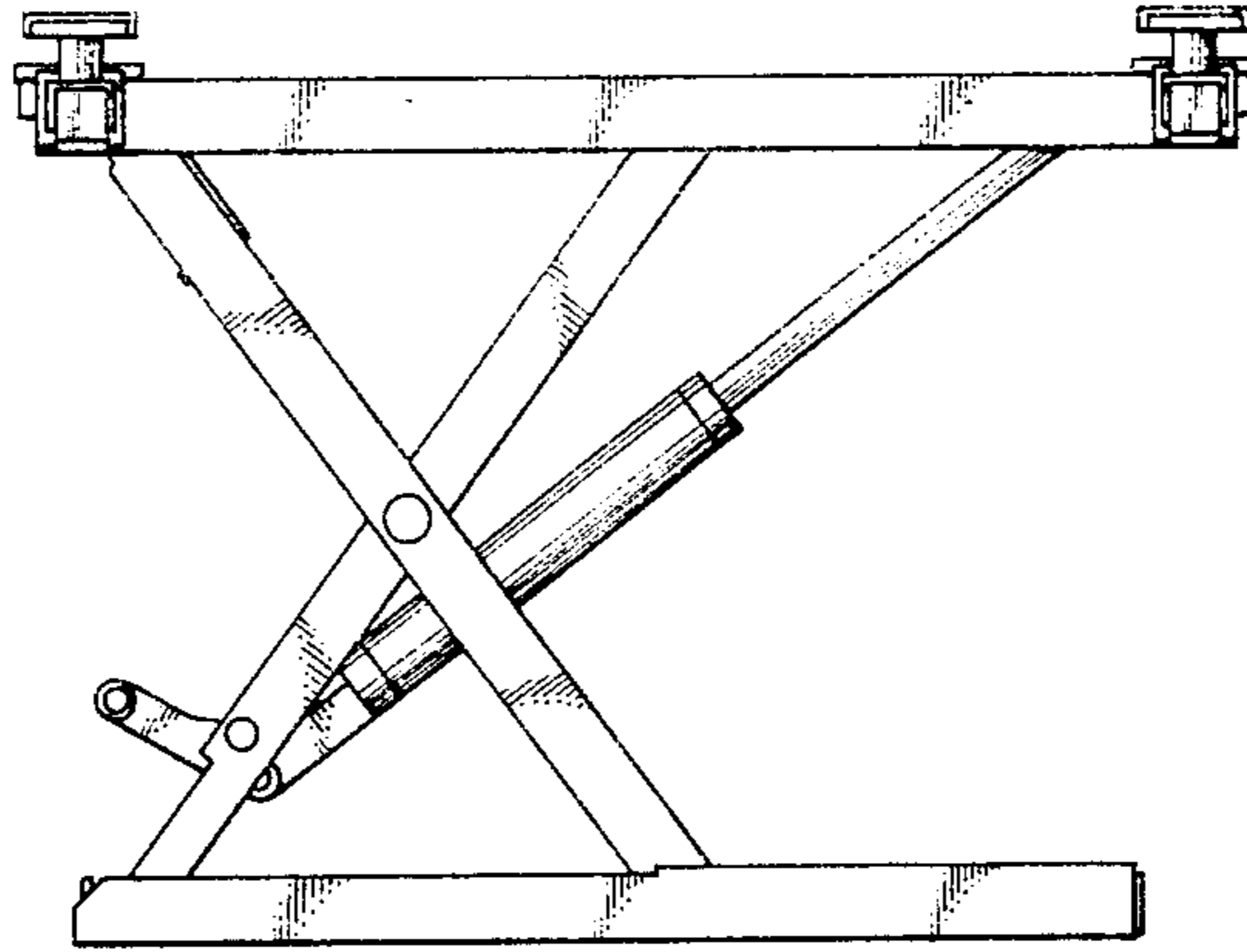

FIG. 3

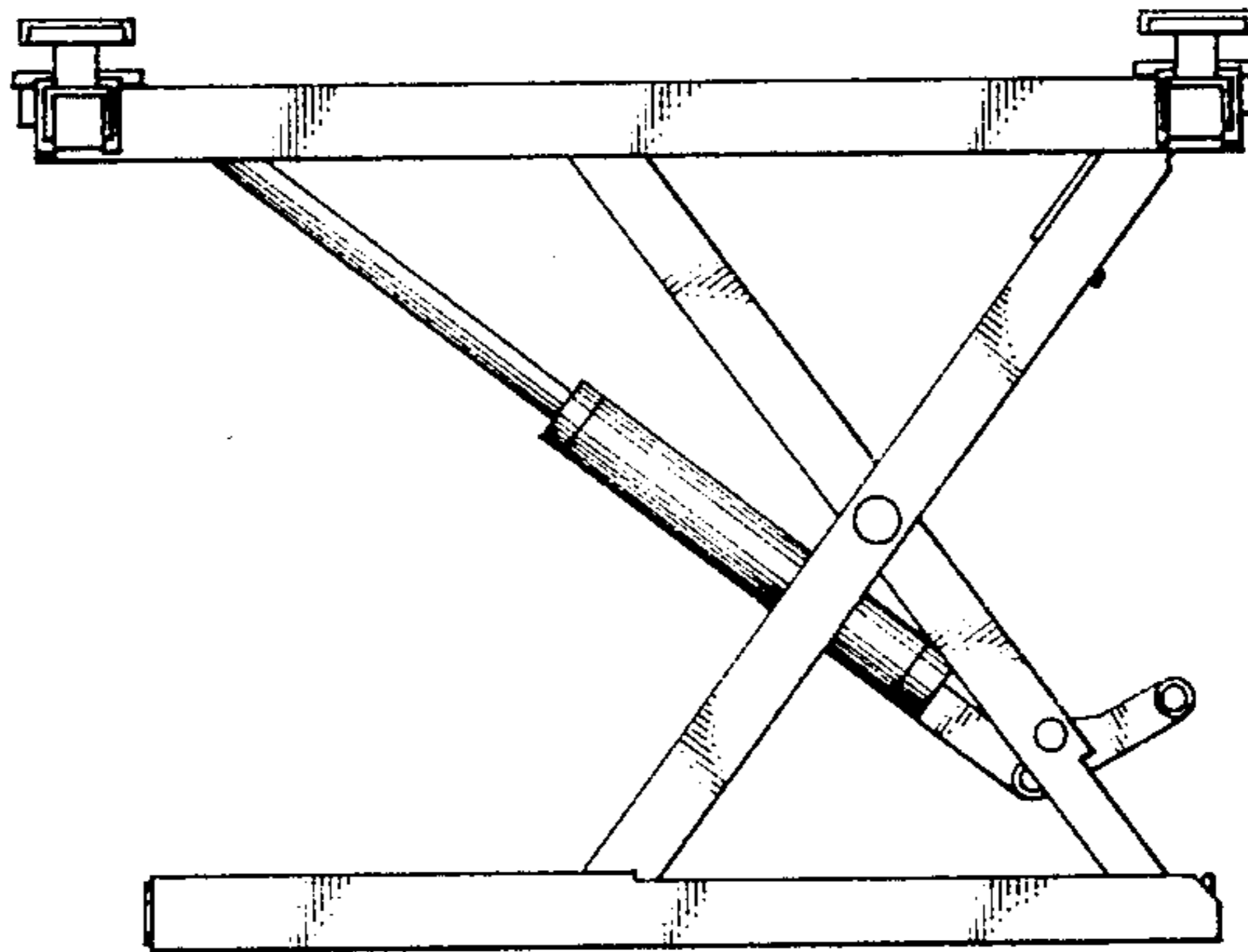

FIG. 4

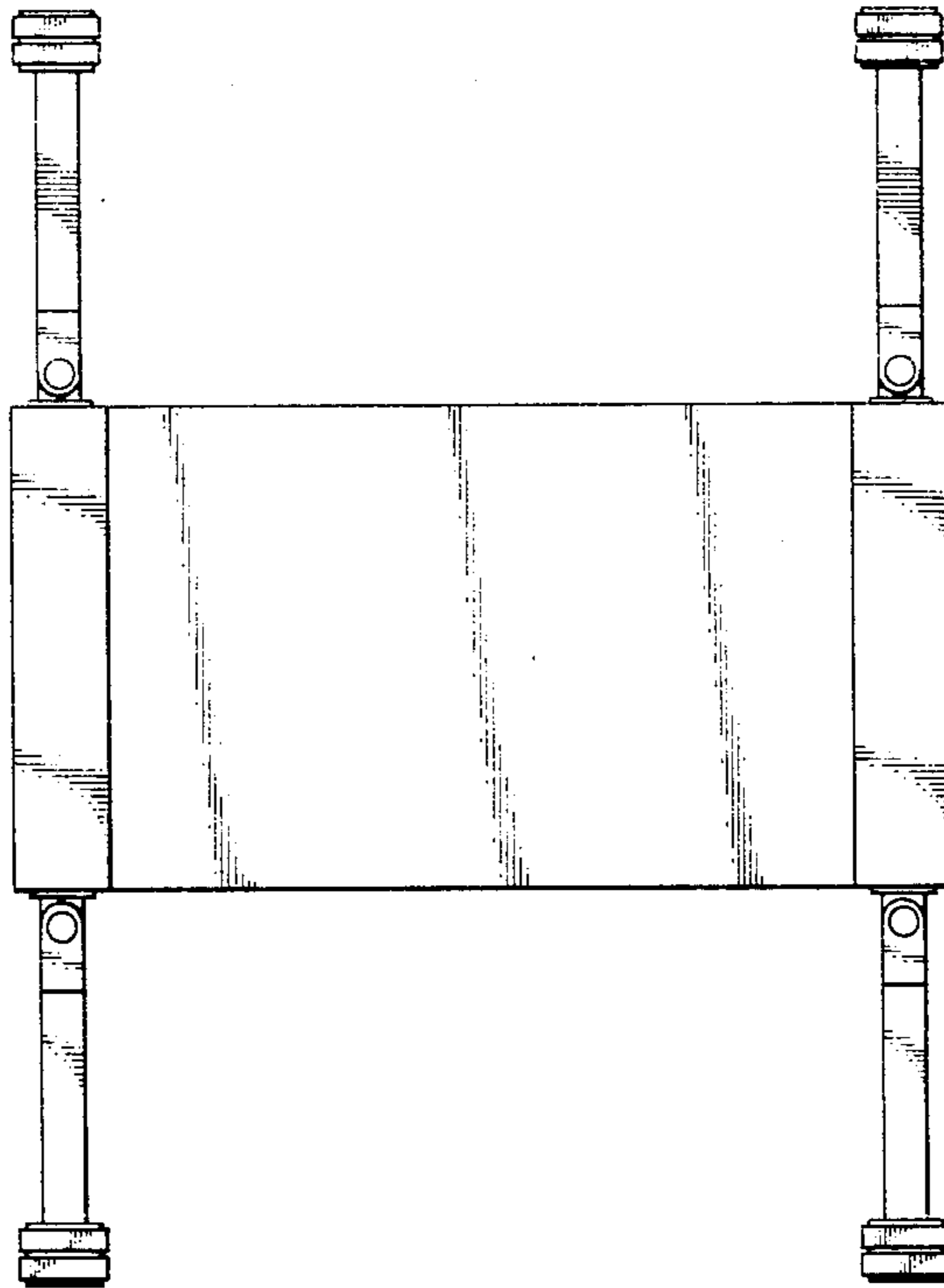

FIG. 5

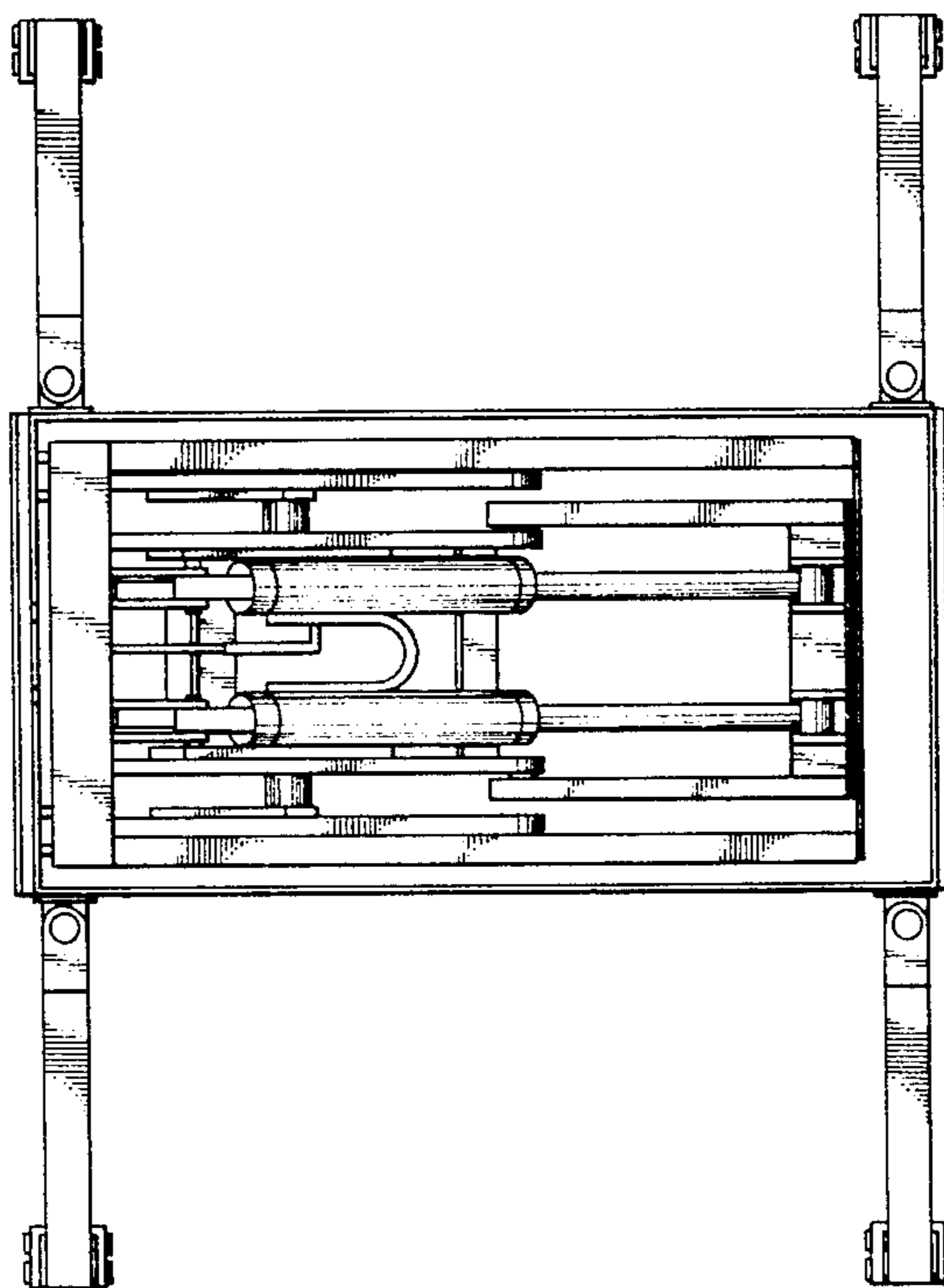

FIG. 6

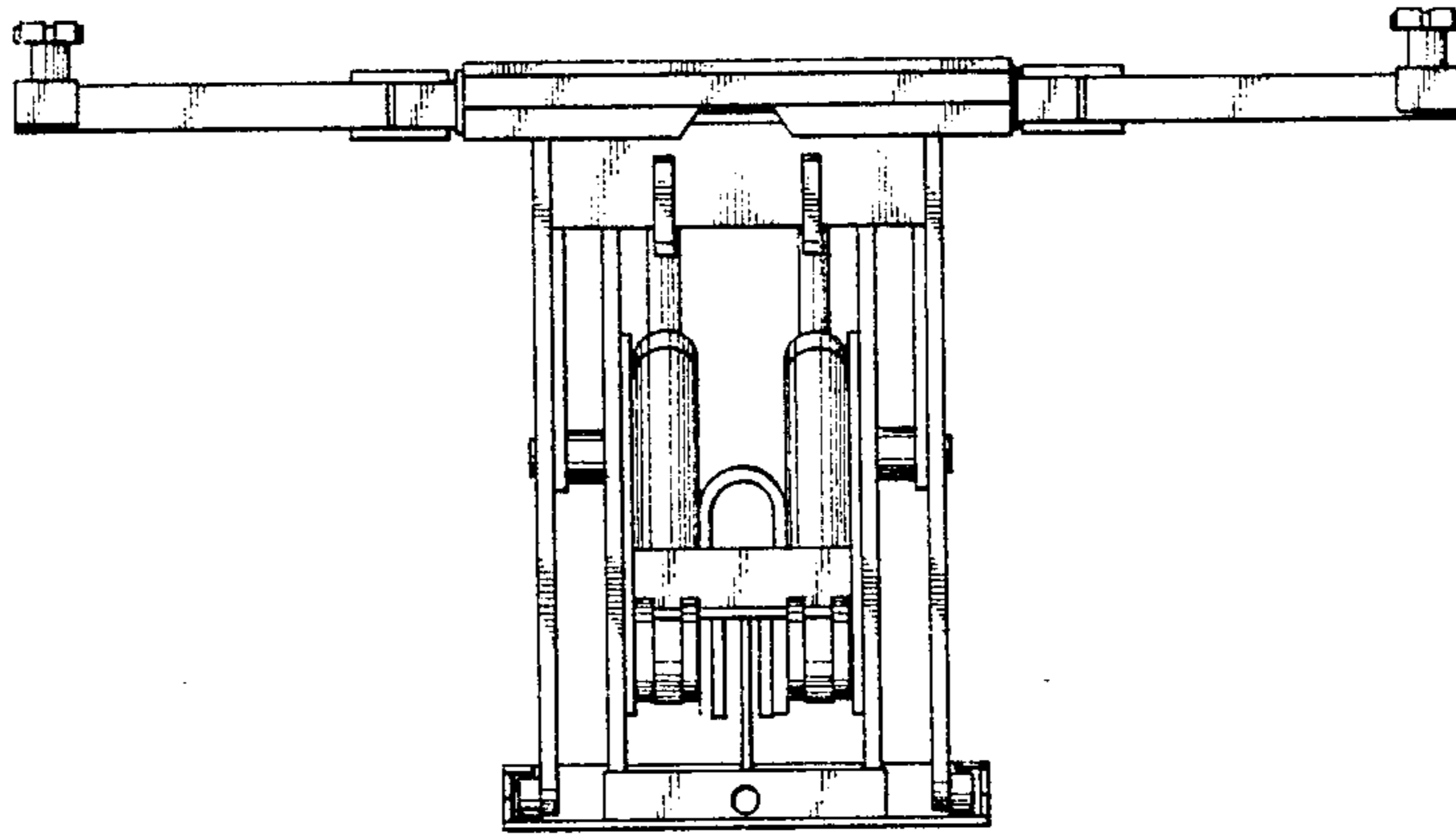

FIG. 7

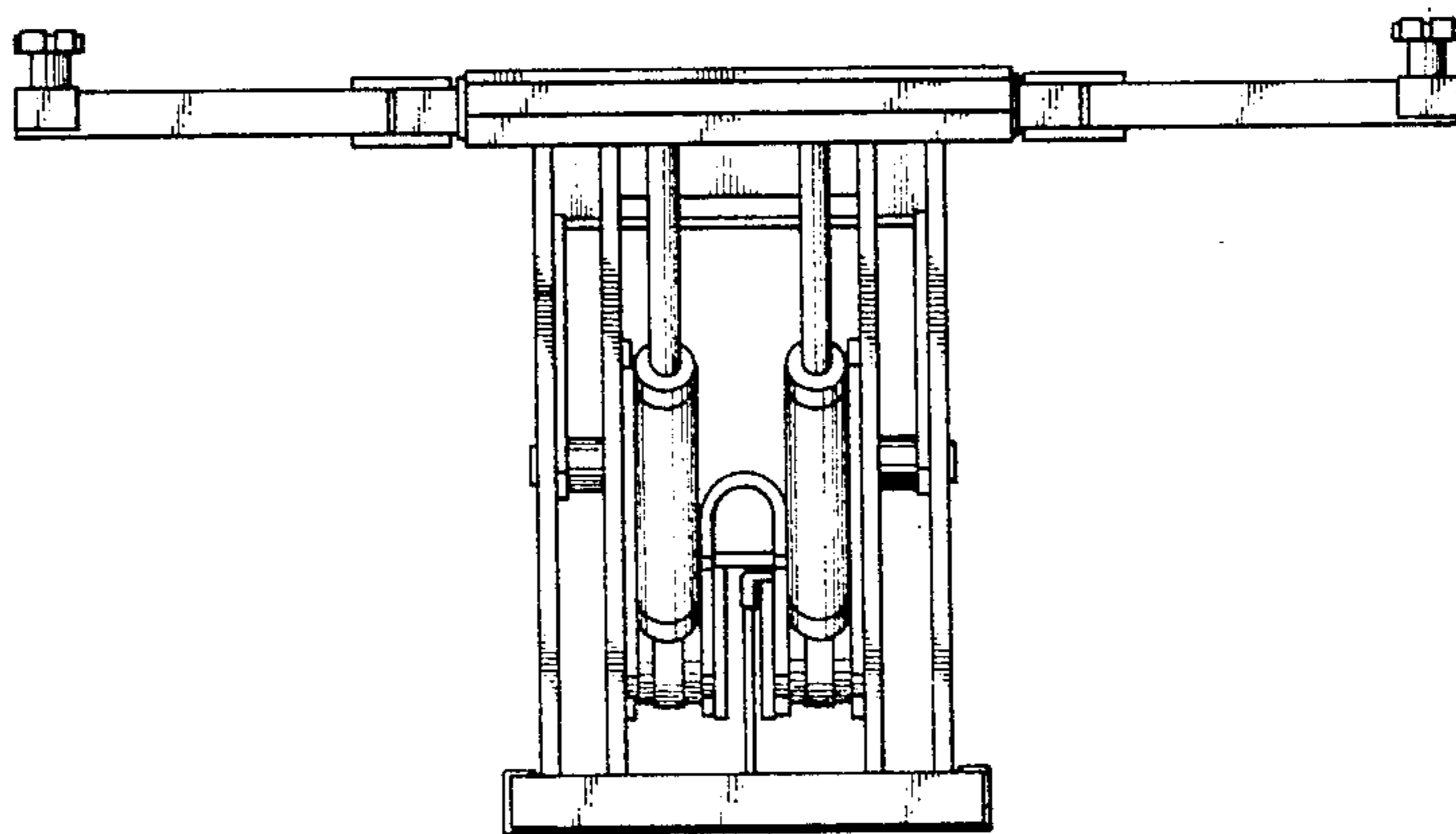

FIG. 8

