

[54] WATERBOARD FIN

[76] Inventor: Lawrence S. Bucknell, 62-202 Kamehameha Hwy., Haleiwa, Hi. 96712

[**] Term: 14 Years

[21] Appl. No.: 150,533

[22] Filed: Jan. 28, 1988

[52] U.S. Cl. D21/231; D12/317

[58] Field of Search D21/230, 231, 236; D12/317; 114/126, 127, 129, 132, 140; 441/74, 79

[56] References Cited

U.S. PATENT DOCUMENTS

- 3,201,807 8/1965 Weaver 441/79
- 4,320,546 3/1982 Knox 441/74
- 4,789,368 12/1988 D'Onofrio 441/74

FOREIGN PATENT DOCUMENTS

- 2576867 8/1986 France 114/127

OTHER PUBLICATIONS

Washington Post Newspaper, 1/29/87, "How Stars and Stripes and Kookaburra III Differ".

Primary Examiner—Wallace R. Burke
Assistant Examiner—Kay H. Chin
Attorney, Agent, or Firm—Martin E. Hsia

[57] CLAIM

The ornamental design for a waterboard fin, as shown and described.

DESCRIPTION

FIG. 1 is a rear perspective view of a waterboard fin showing my new design, the broken line being for illustrative purposes only and forming no part of the claimed design;

FIG. 2 is a top plan view thereof;

FIG. 3 is a rear elevational view thereof;

FIG. 4 is a front elevational view thereof;

FIG. 5 is a bottom plan view thereof; and

FIG. 6 is a right side elevational view thereof, the left side elevational view thereof being a mirror image of that shown.

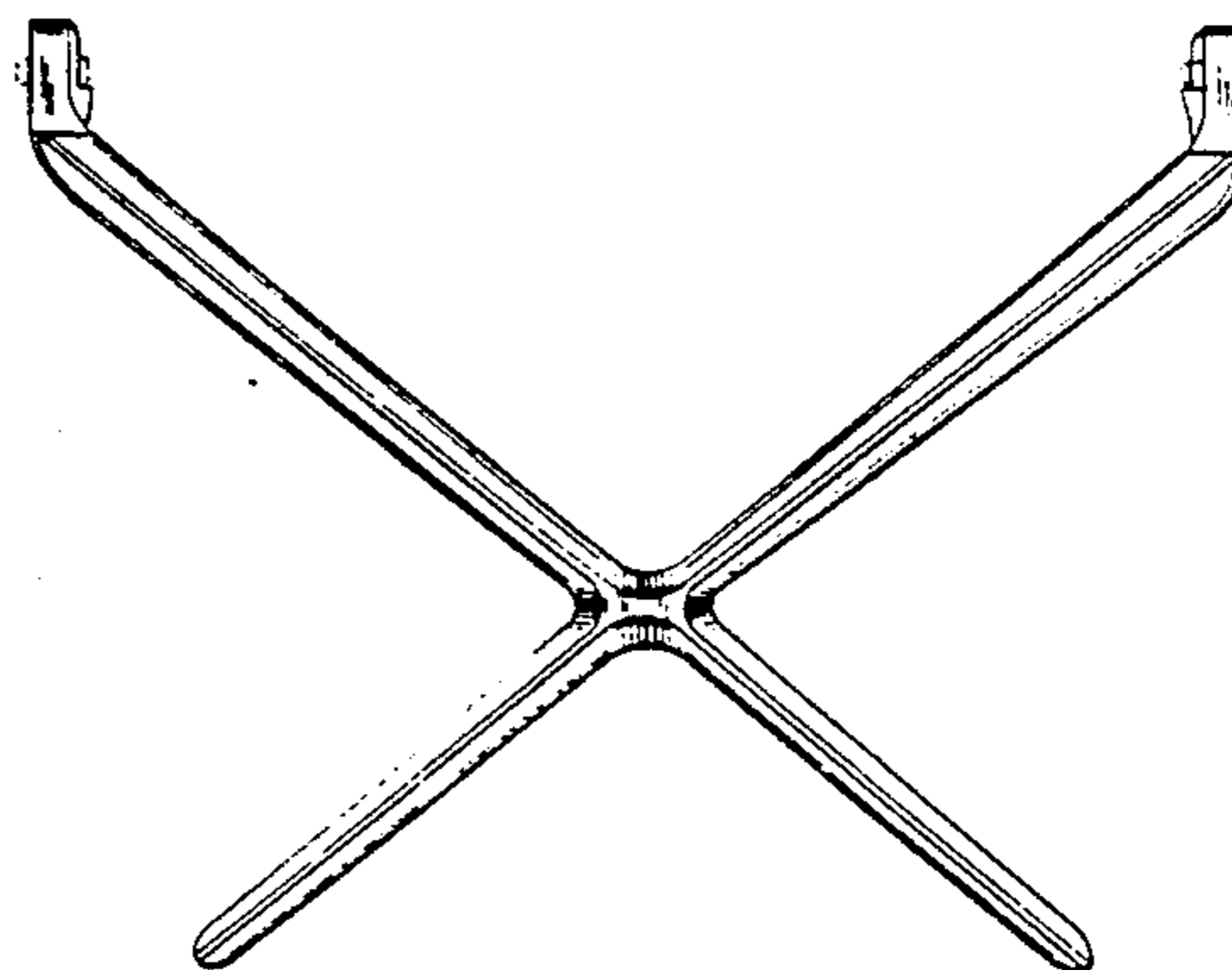
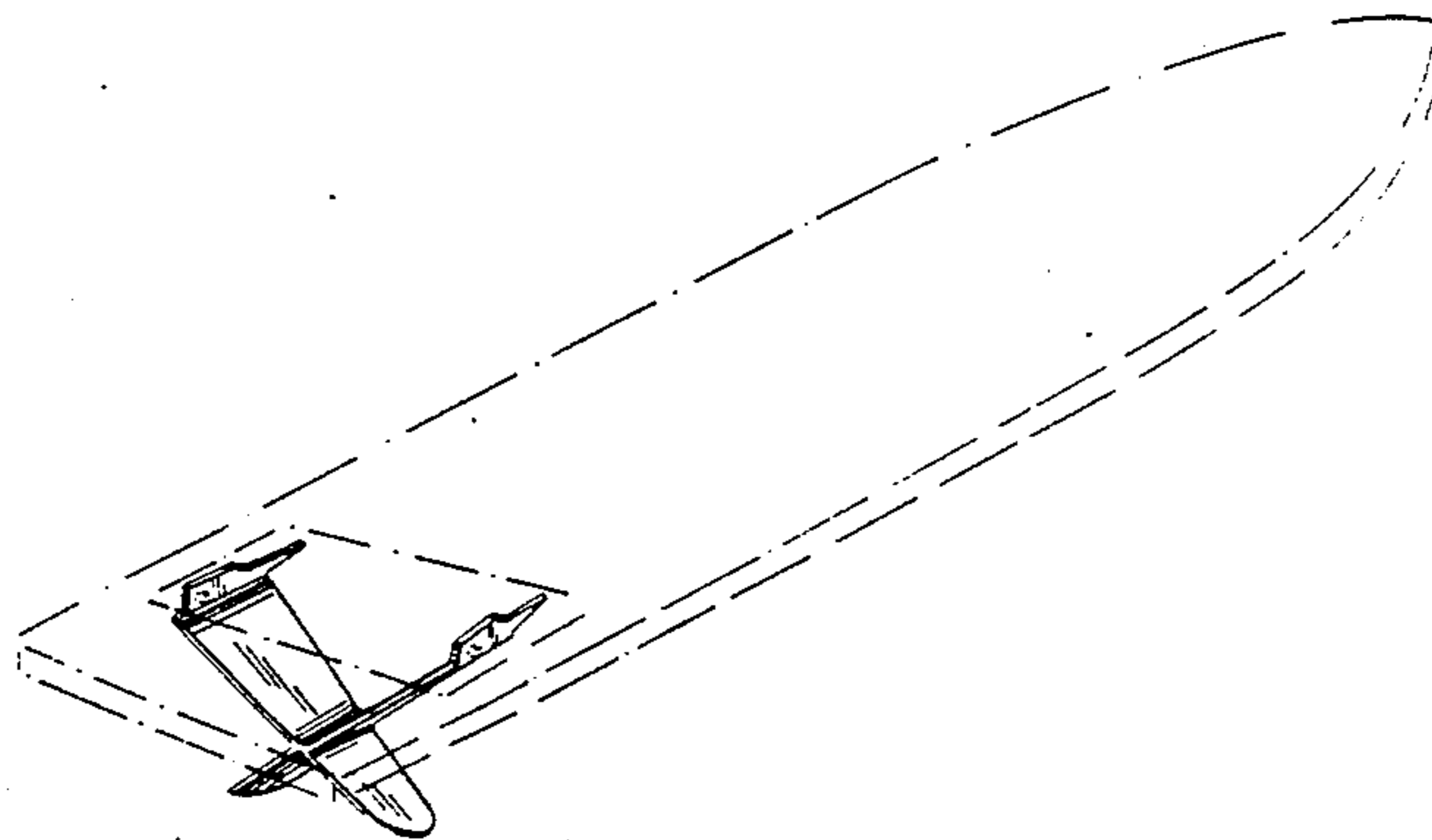

FIG. 1

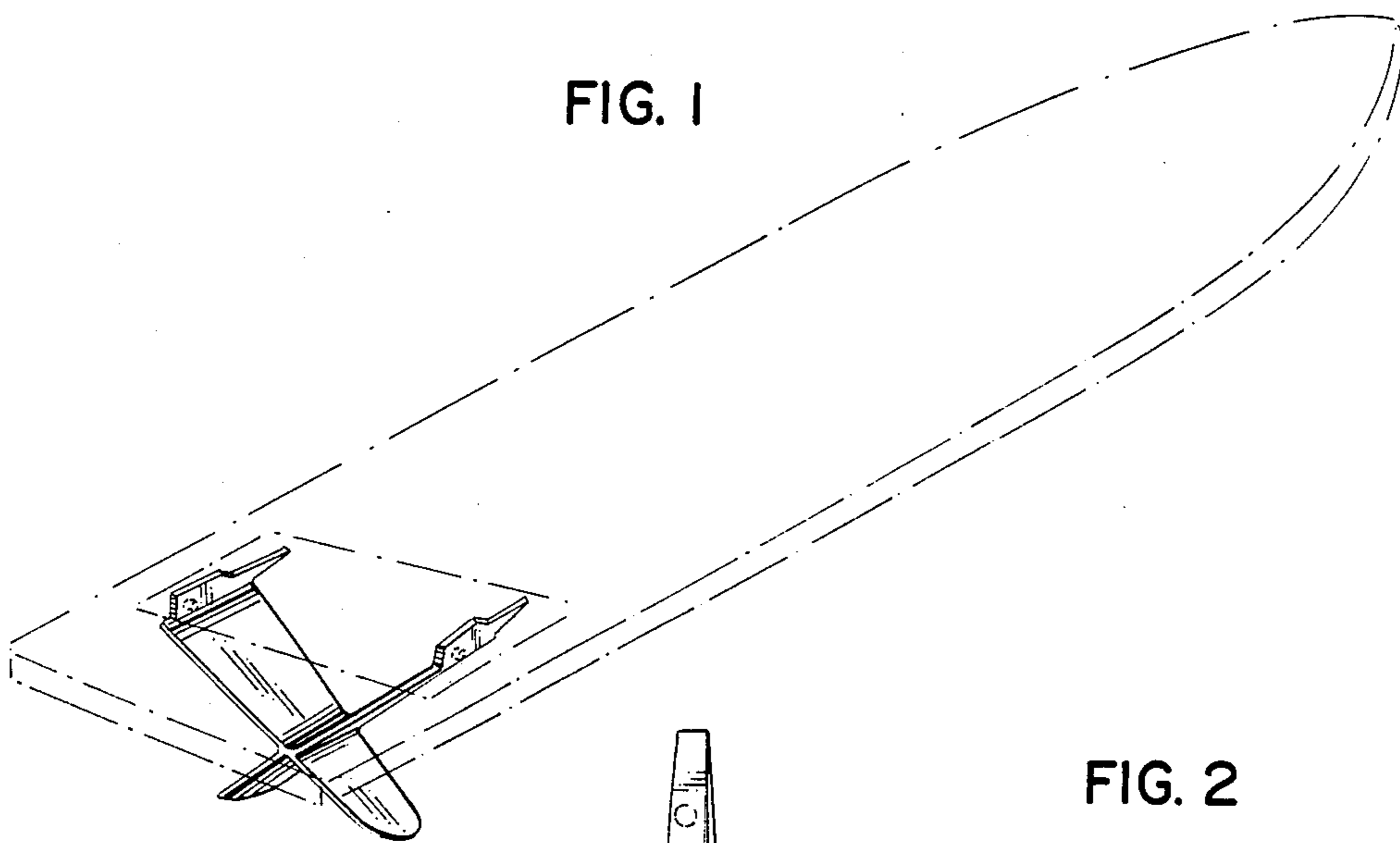

FIG. 2

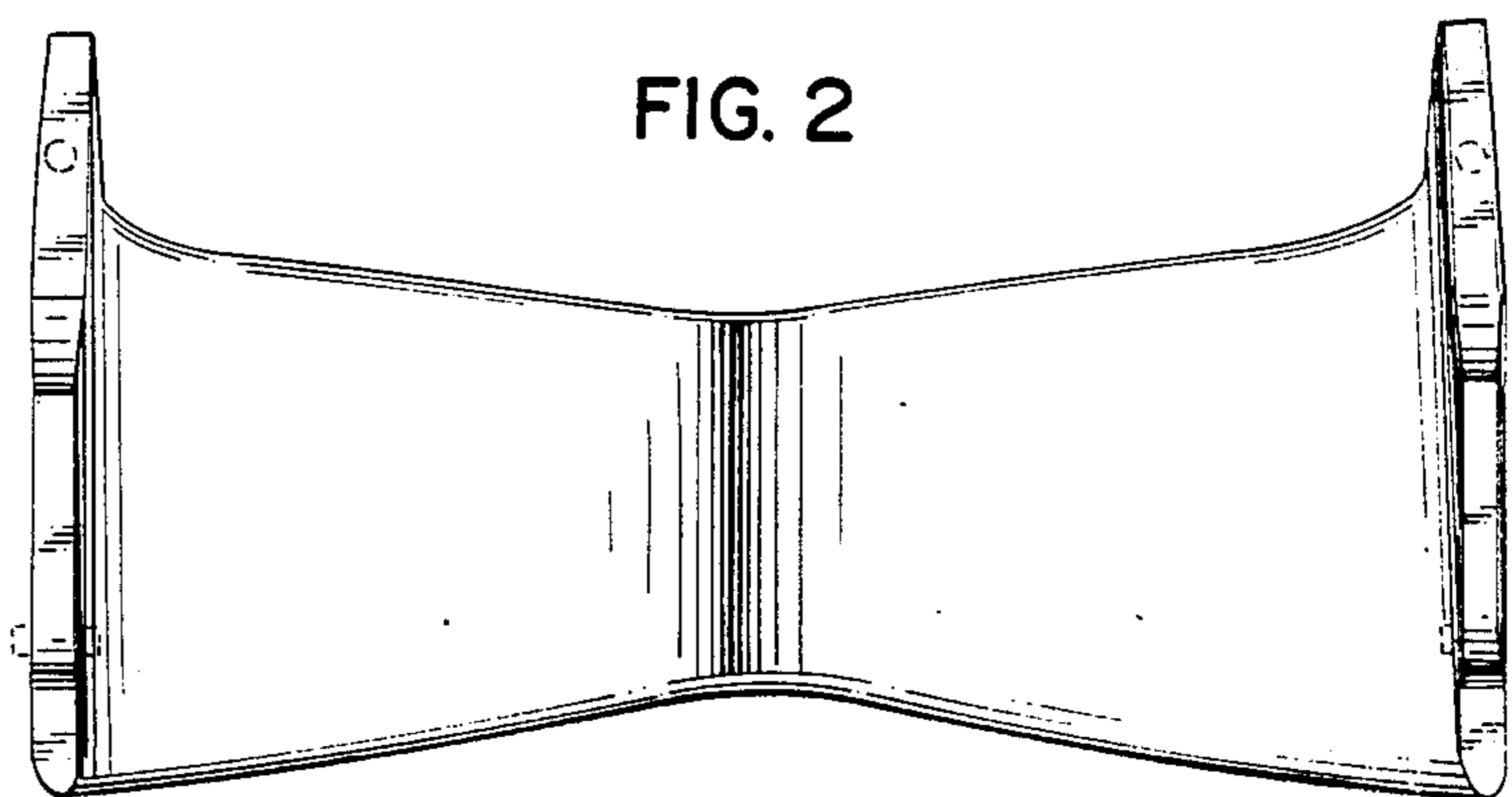

FIG. 3

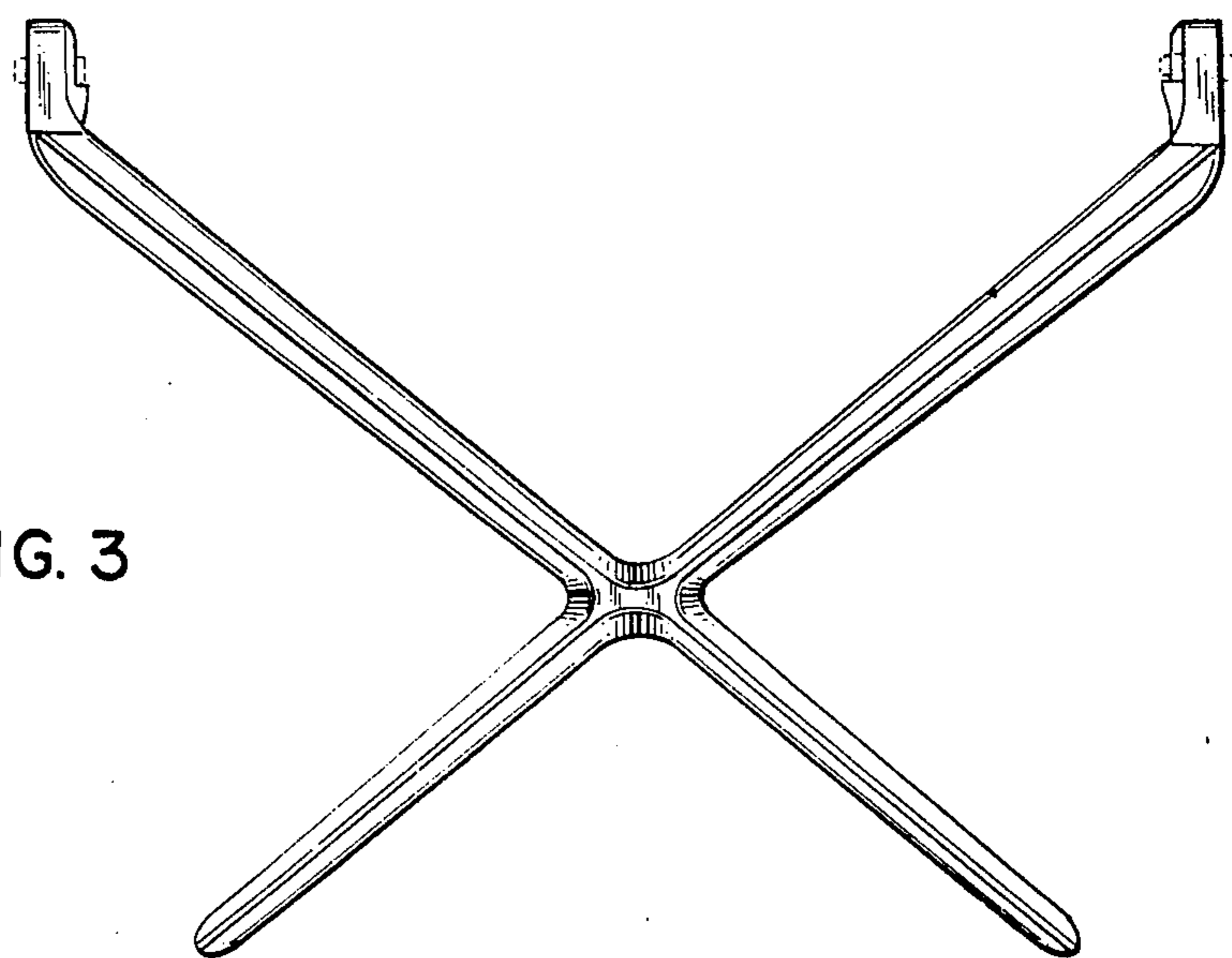

FIG. 4

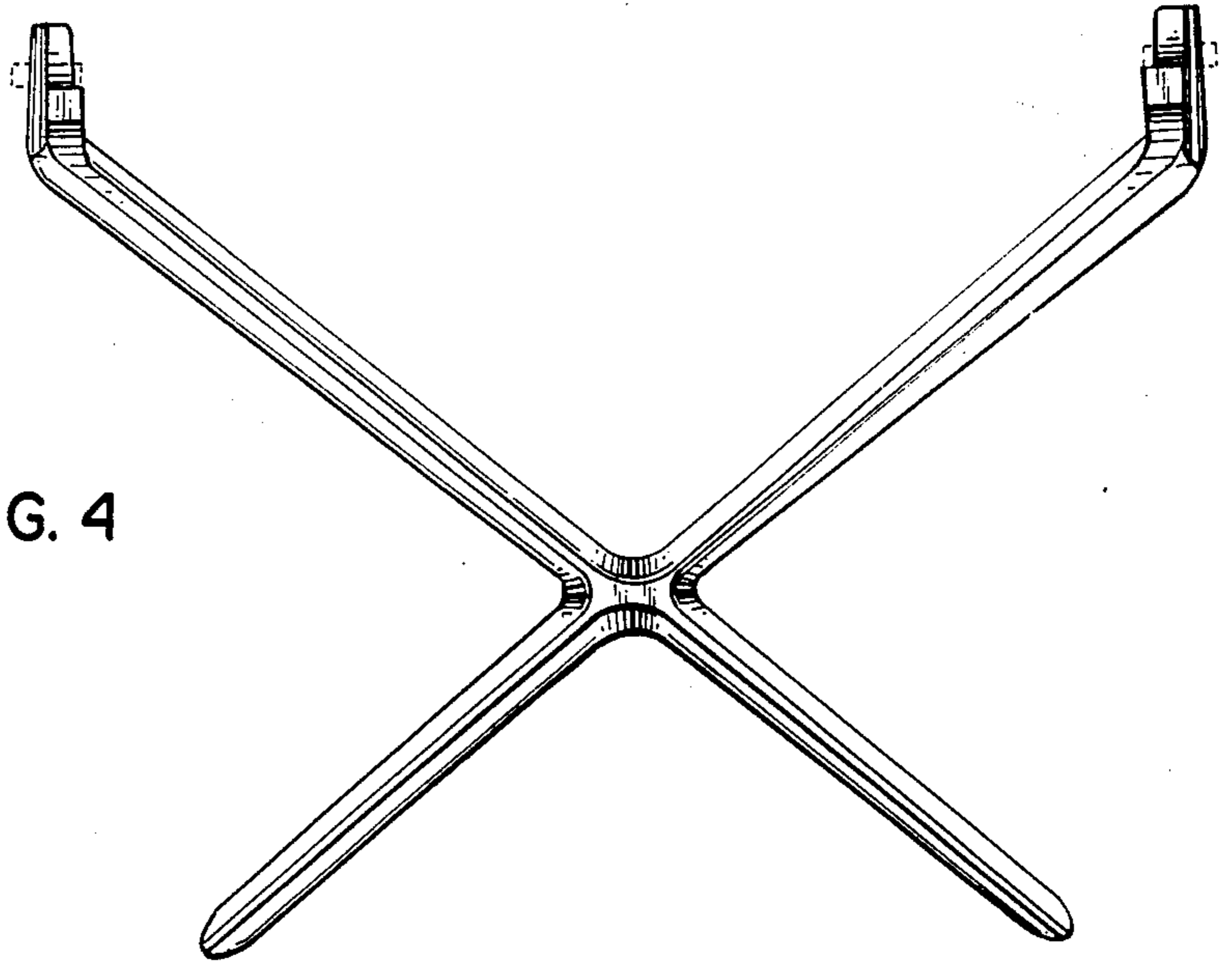

FIG. 5

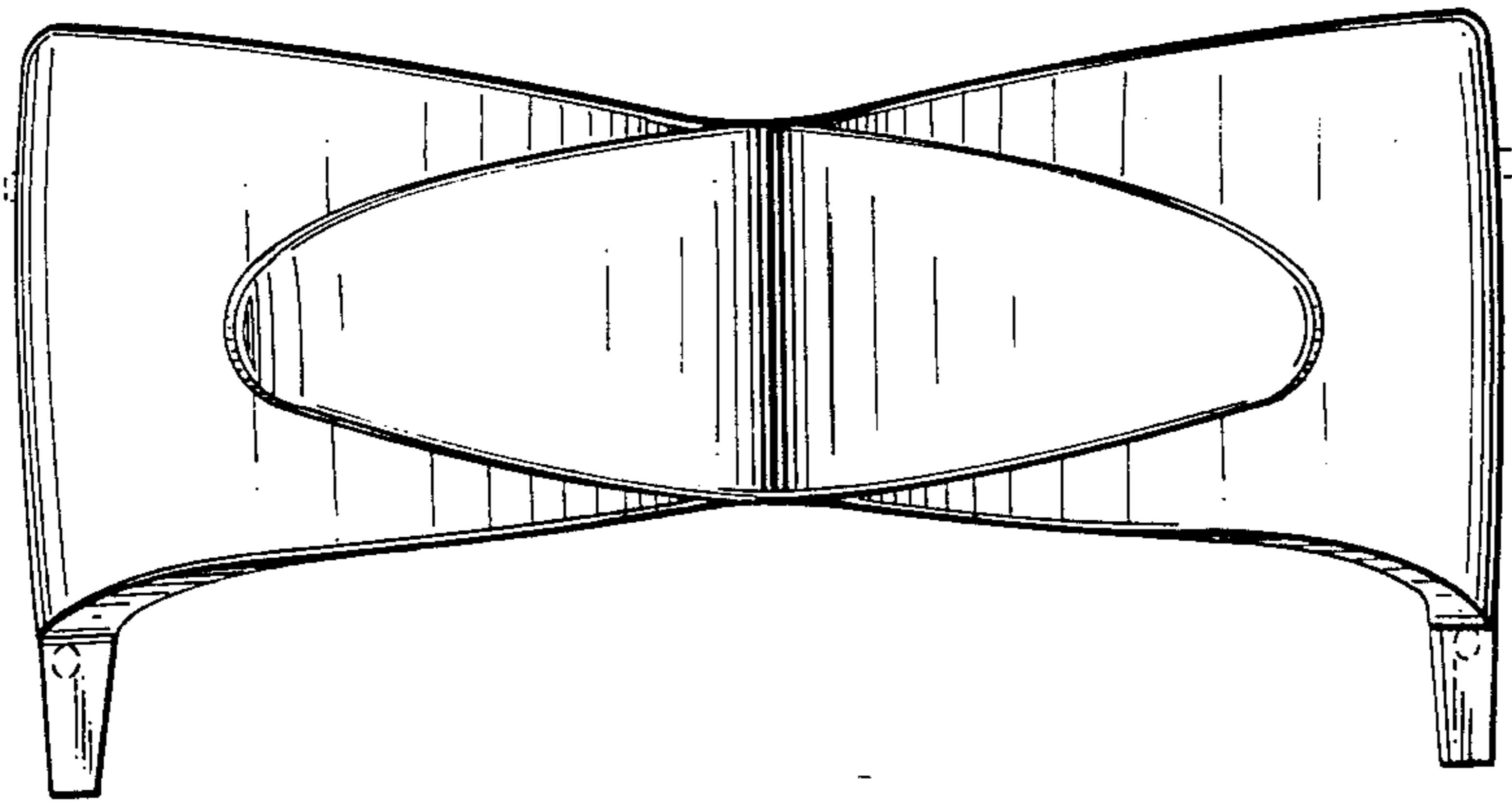

FIG. 6

