

[54] TOY CLOCK ROBOT

[75] Inventor: Hiroshi Horiuchi, Tokyo, Japan

[73] Assignee: Tomy Kogyo Co., Inc., Tokyo, Japan

[**] Term: 14 Years

[21] Appl. No.: 46,303

[22] Filed: May 5, 1987

[30] Foreign Application Priority Data

Nov. 8, 1986 [JP] Japan 61 44216

[52] U.S. Cl. D21/121; D10/38; D21/150

[58] Field of Search D21/166, 59, 150, 121; D10/8, 6; D99/38, 37; 446/8, 10, 11, 12

[56] References Cited

U.S. PATENT DOCUMENTS

D. 174,588 4/1955 Noble D21/166

D. 217,489 5/1970 Perhacs D21/166
D. 247,740 4/1978 Brady D10/6
D. 250,052 10/1978 Salt et al. D21/166
D. 251,628 4/1979 McQuarrie et al. D21/166

OTHER PUBLICATIONS

Hong Kong Toys '87, p. 7, item #1121ER, Robot.

Primary Examiner—Charles A. Rademaker
Attorney, Agent, or Firm—Staas & Halsey

[57] CLAIM

The ornamental design for a toy clock robot, as shown.

DESCRIPTION

FIG. 1 is a front elevational view of a toy clock robot showing my new design;
FIG. 2 is a rear elevational view thereof;
FIG. 3 is a right side elevational view thereof;
FIG. 4 is a left side elevational view thereof;
FIG. 5 is a top plan view thereof; and
FIG. 6 is a bottom plan view thereof.

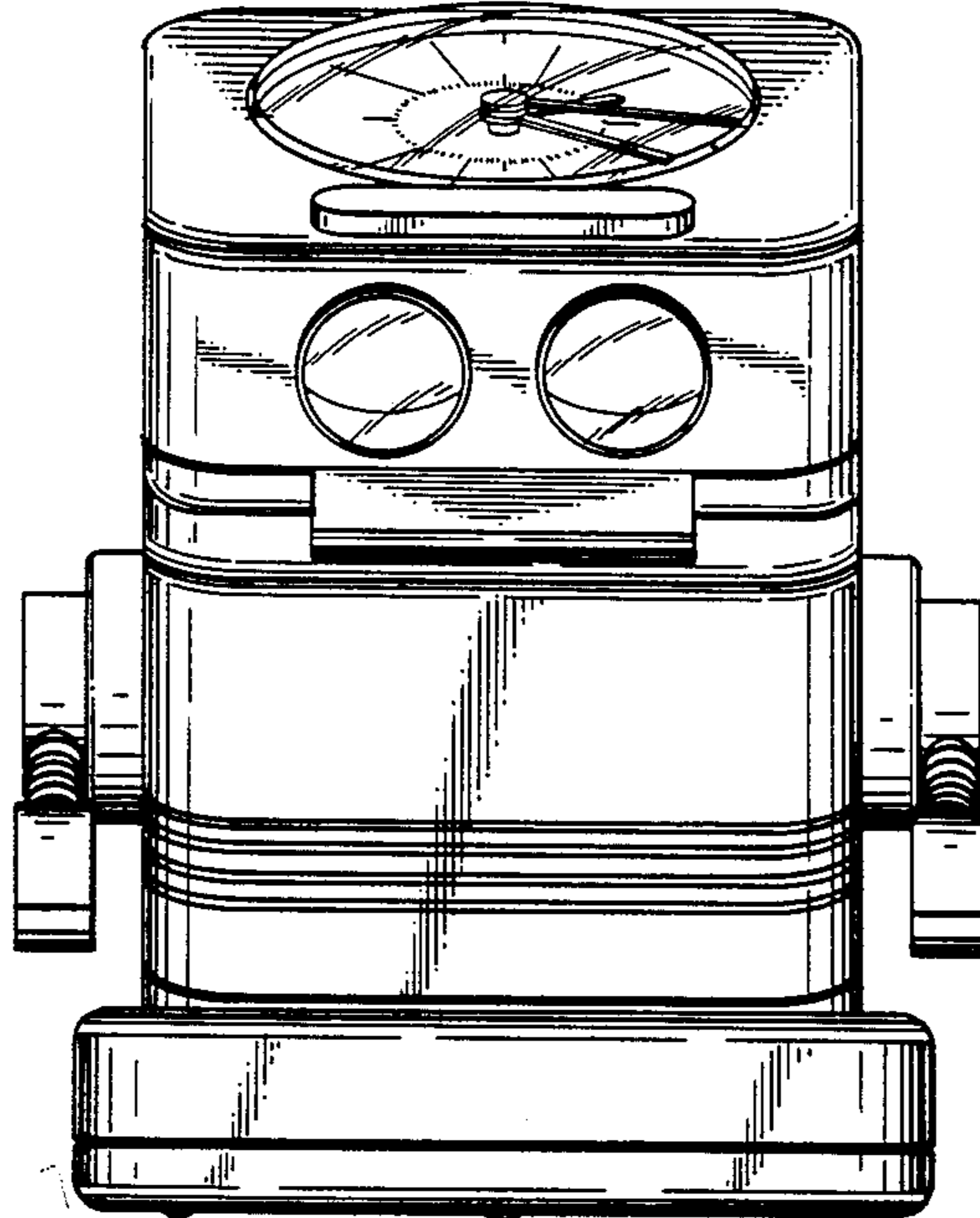

FIG. 2

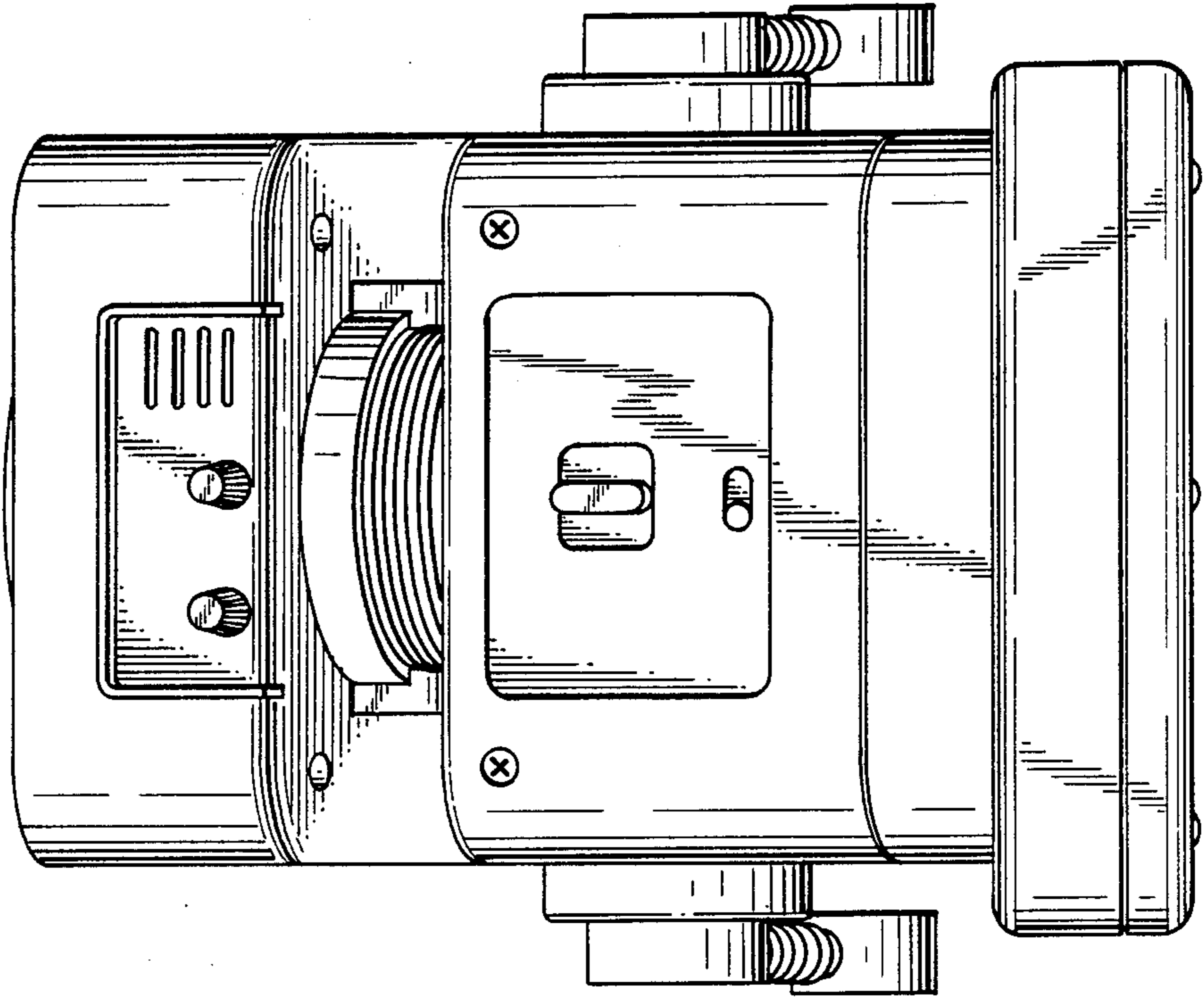

FIG. 1

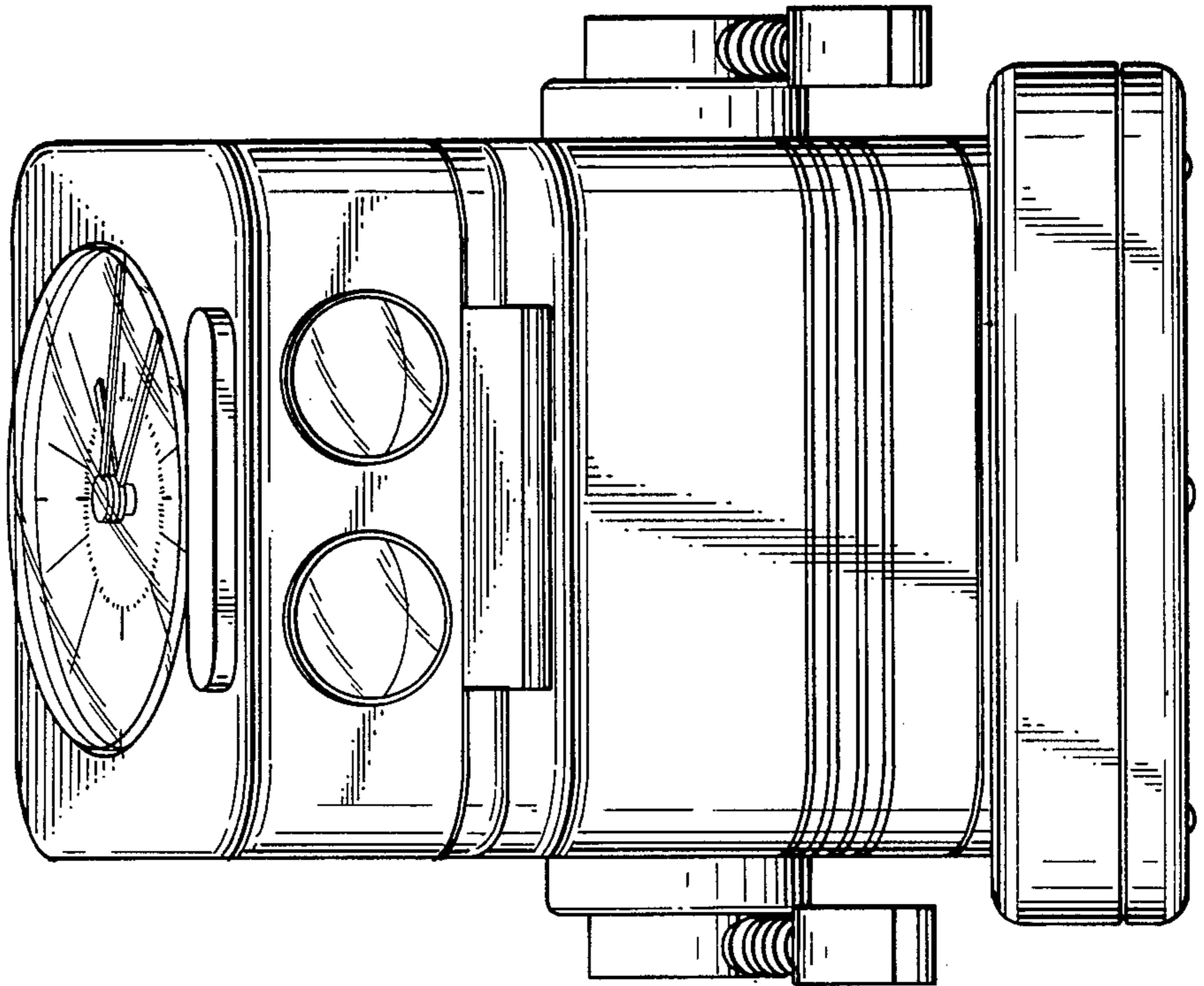

FIG. 4

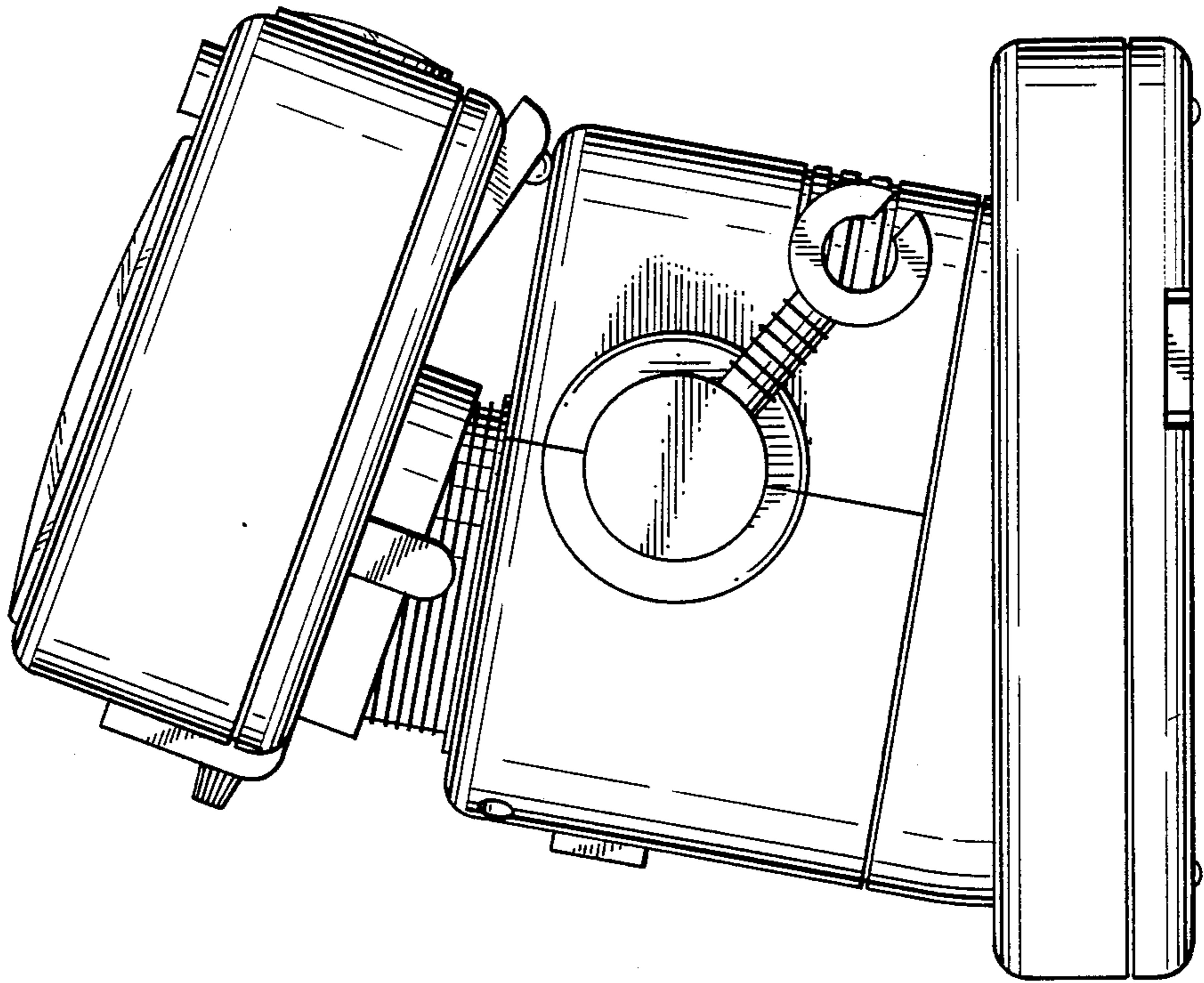

FIG. 3

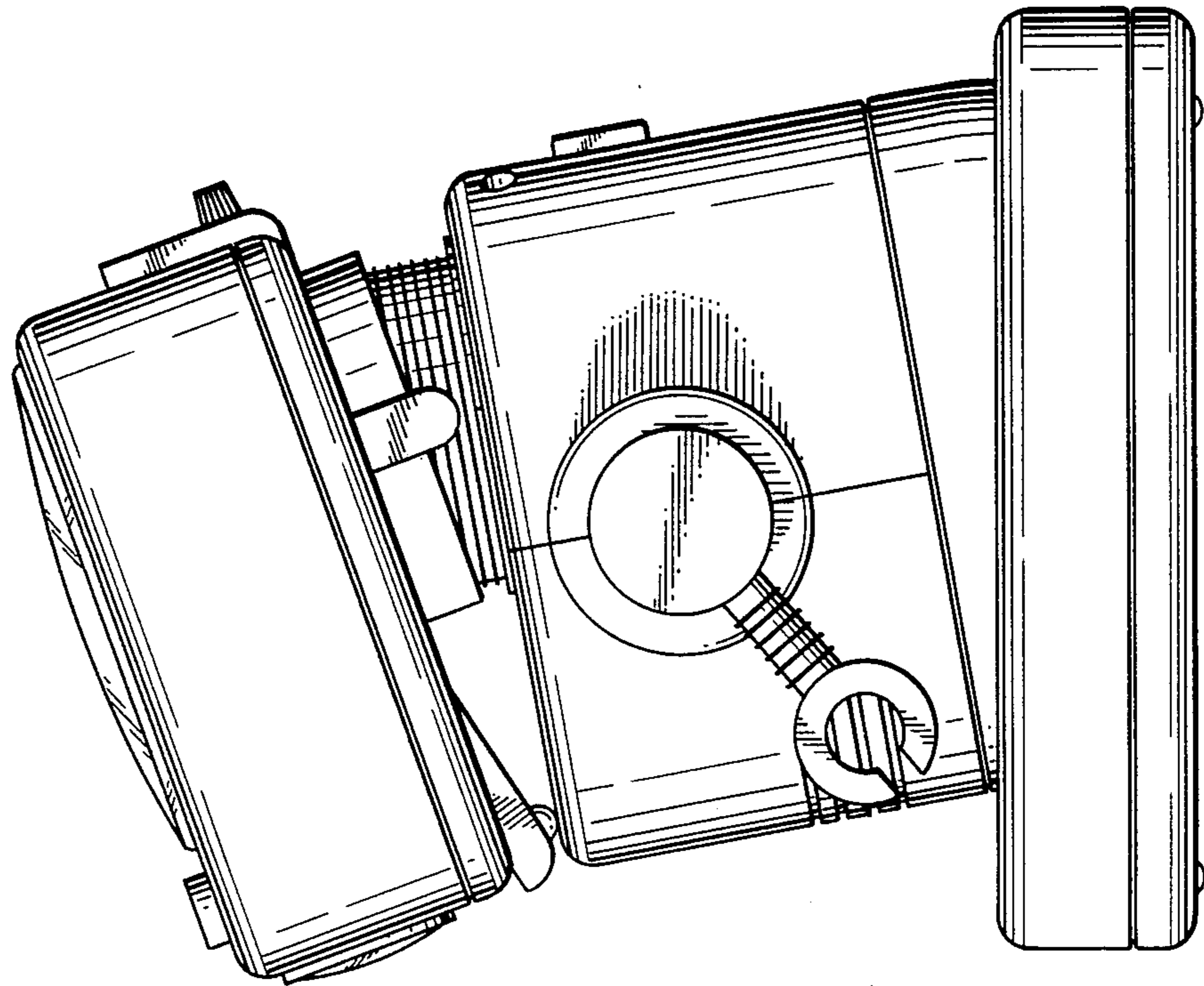

FIG. 5

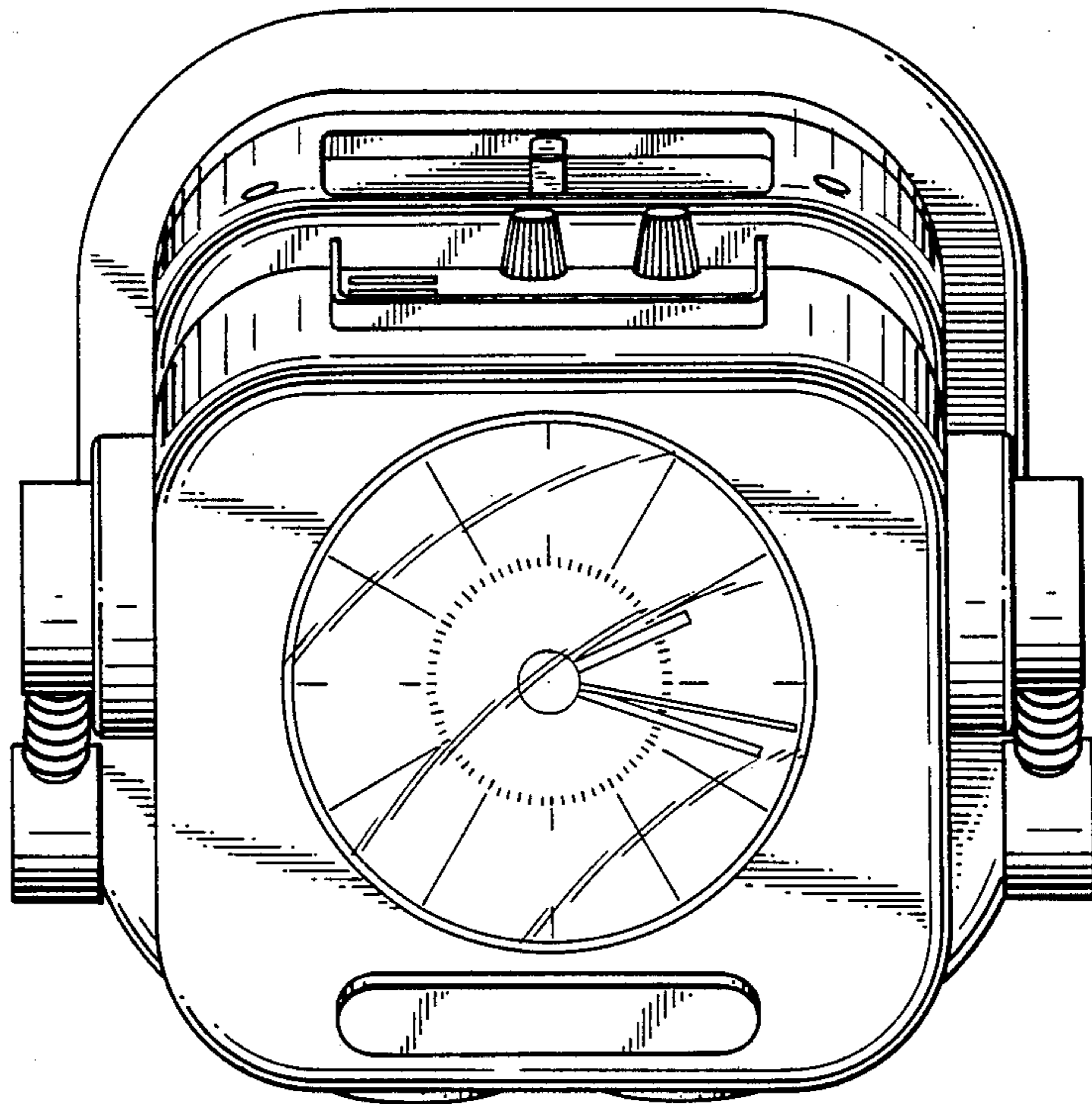

FIG. 6

