

[54] **AIRCRAFT HOT AIR RELEASE SHROUD**

4,418,708 12/1983 Schulze et al. 244/53 B

[76] **Inventor: Hiram B. Holt, 1713 Betty St., SW., Decatur, Ala. 35601**

Primary Examiner—Wallace R. Burke
Assistant Examiner—Kay H. Chin
Attorney, Agent, or Firm—C. A. Phillips

[**] **Term: 14 Years**

[21] **Appl. No.: 124,467**

[22] **Filed: Nov. 23, 1987**

[52] **U.S. Cl. D12/345**

[58] **Field of Search D12/319, 345; 244/57, 244/53 B**

[57] **CLAIM**

The ornamental design for an aircraft hot air release shroud, as shown and described.

DESCRIPTION

FIG. 1 is a side perspective view of an aircraft hot air release shroud showing my new design; FIG. 2 is an enlarged top and right side perspective view thereof; FIG. 3 is an enlarged top and left side perspective view thereof; and FIG. 4 is a front elevational view thereof. The broken lines shown in FIGS. 1 through 4 are for illustrative purposes only and form no part of the claimed design.

[56] **References Cited**

U.S. PATENT DOCUMENTS

3,129,910	4/1964	Smith	244/53 B
3,717,163	2/1973	Herr	244/53 B
3,838,425	9/1974	Ishimitsu et al.	244/53 B
4,372,505	2/1983	Syberg	244/53 B
4,378,097	3/1983	Ferguson et al.	244/53 B

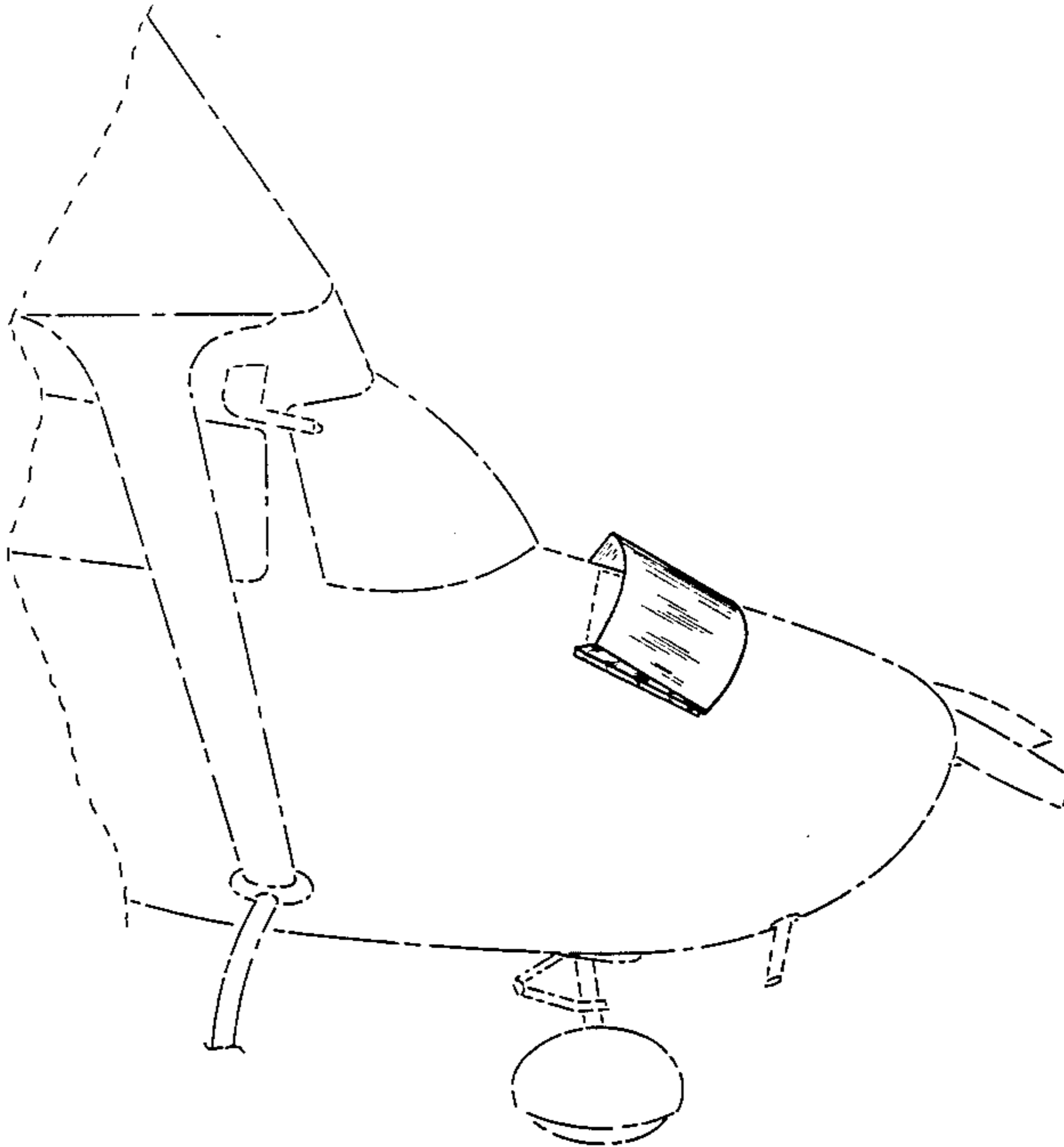

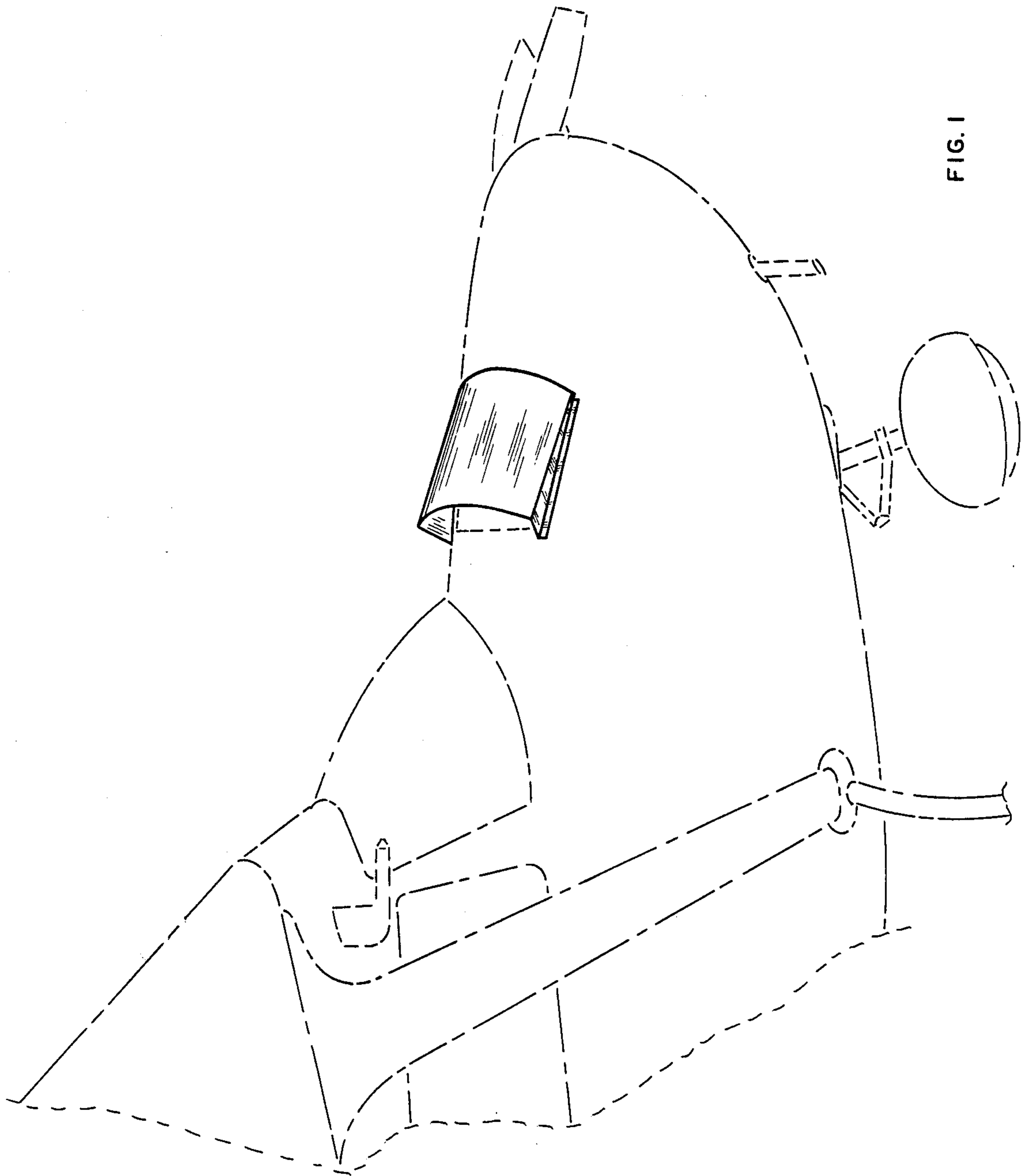

FIG. 1

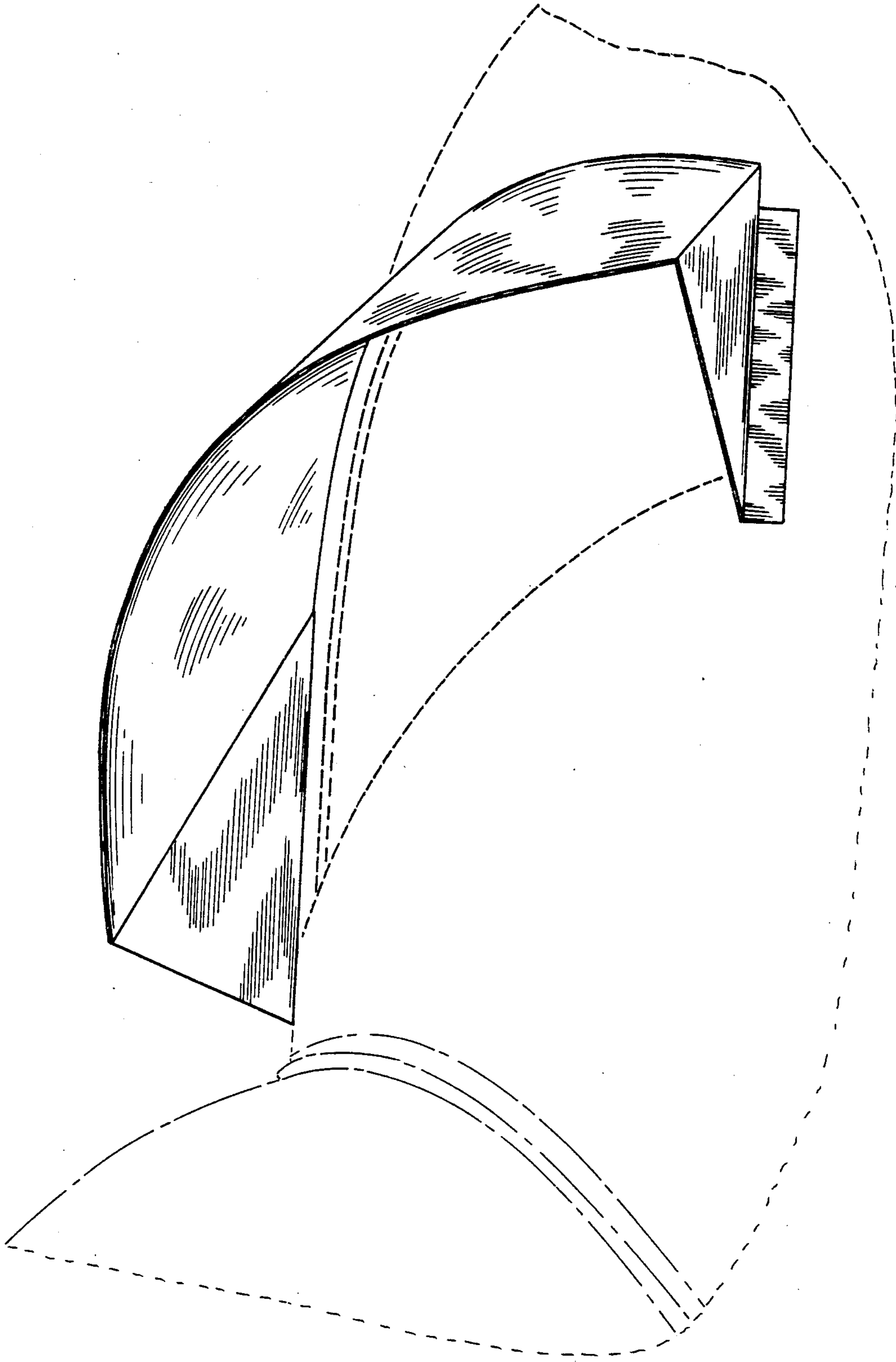

FIG. 2

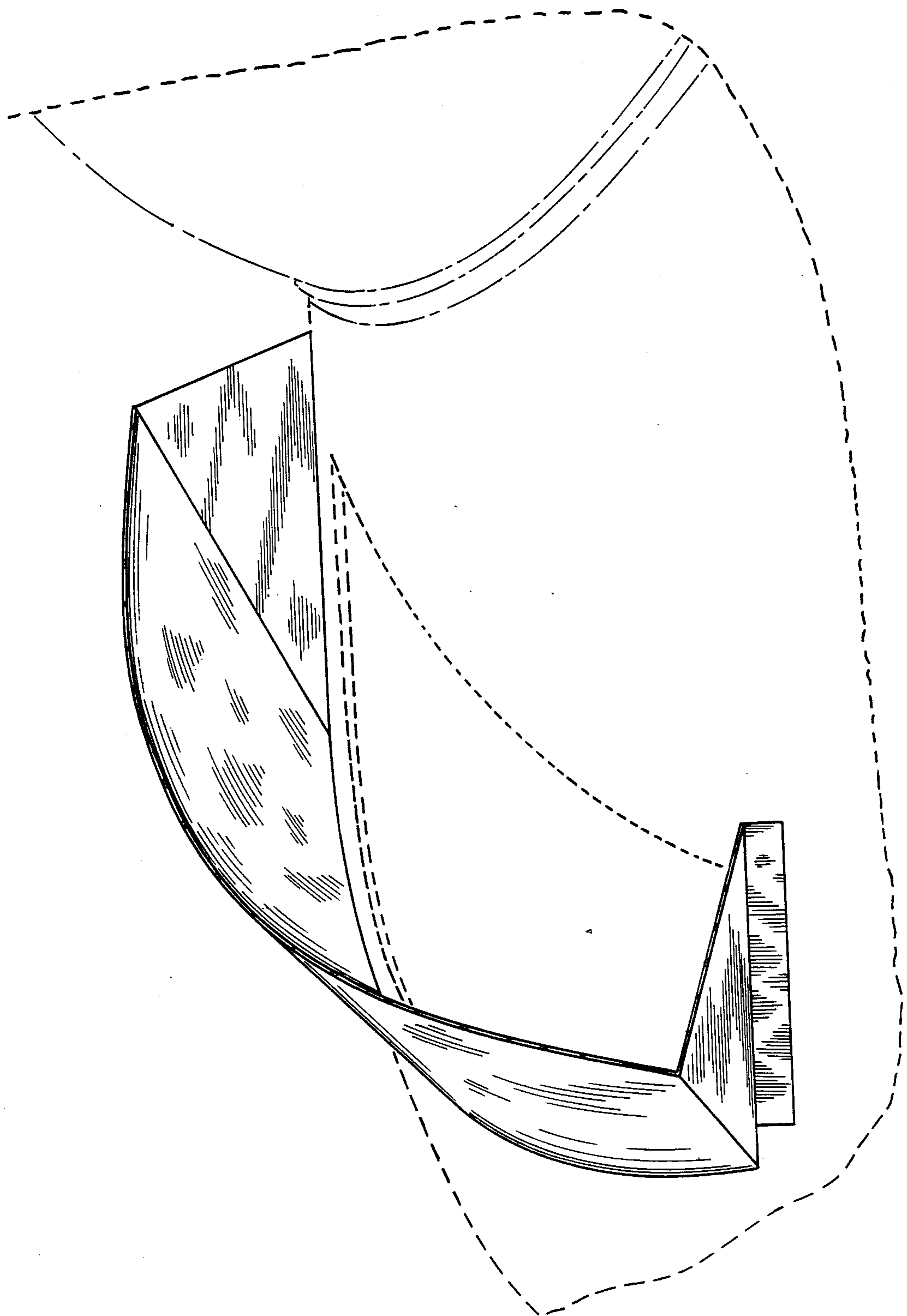

FIG. 3

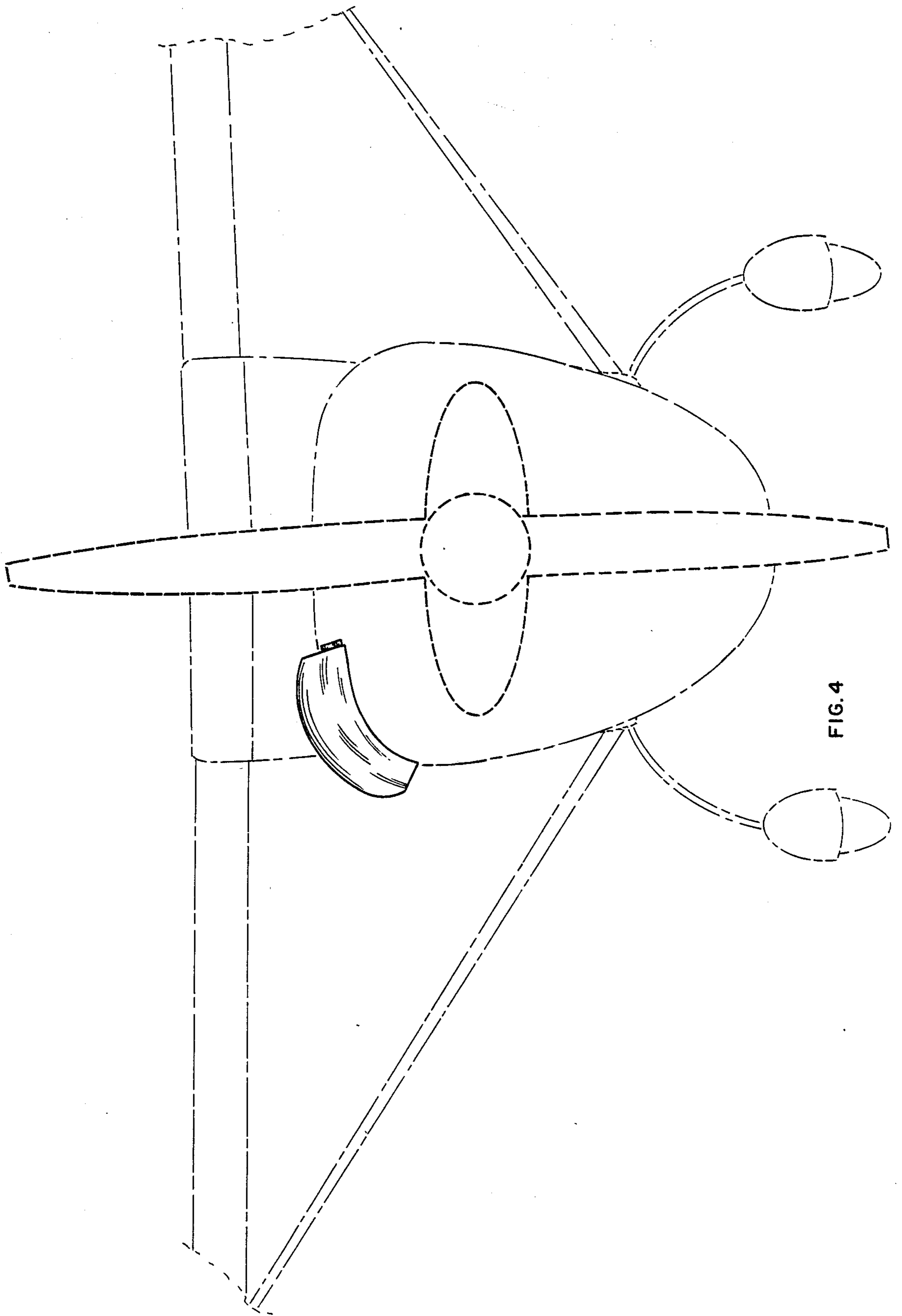

FIG. 4