

[54] FRONT BUMPER FOR AN AUTOMOBILE

[75] Inventors: Yoshihiro Hamasaki, Toyota; Kazumi Fukagawa, Tokyo, both of Japan

[73] Assignee: Toyota Jidosha Kabushiki Kaisha, Toyota, Japan

[**] Term: 14 Years

[21] Appl. No.: 49,087

[22] Filed: May 13, 1987

[52] U.S. Cl. D12/169

[58] Field of Search D12/169; 293/102, 120

[56] References Cited

U.S. PATENT DOCUMENTS

- D. 248,156 6/1978 Tixier D12/169
- D. 282,653 2/1986 Takano D12/169
- D. 286,525 11/1986 Sasaoka D12/169
- D. 288,194 2/1987 Okumura D12/169
- D. 299,636 1/1989 Kubo D12/169

FOREIGN PATENT DOCUMENTS

- 58-8591 11/1982 Japan .
- 638703 11/1984 Japan .
- 588591-1 5/1985 Japan .
- 588591-2 5/1985 Japan .
- 661047 9/1985 Japan .

OTHER PUBLICATIONS

Motor Trend, 5/86, p. 41, Front Bumper of Plymouth Sundance, bottom left side of page.

Motor Trend, 6/86, P100, Front Bumper of Isuzu 1--Mark, bottom of page.

Motor Trend, 11/86, p. 131, Front Bumper of Toyota Corolla FX16GT-S, bottom of page.

Primary Examiner—James M. Gandy
Attorney, Agent, or Firm—Cushman, Darby & Cushman

[57] CLAIM

The ornamental design for a front bumper for an automobile, as shown and described.

DESCRIPTION

FIG. 1 is a front perspective view of a front bumper for an automobile showing our new design;

FIG. 2 is another front perspective view of the front bumper of FIG. 1;

FIG. 3 is a front elevational view of FIG. 1;

FIG. 4 is a rear elevational view of FIG. 1;

FIG. 5 is a top plan view of FIG. 1;

FIG. 6 is a bottom plan view of FIG. 1;

FIG. 7 is a left side elevational view of FIG. 1;

FIG. 8 is a right side elevational view of FIG. 1;

FIG. 9 is a cross sectional view taken along line IX—IX of FIG. 3; and

FIG. 10 is a cross sectional view taken along line X—X of FIG. 7.

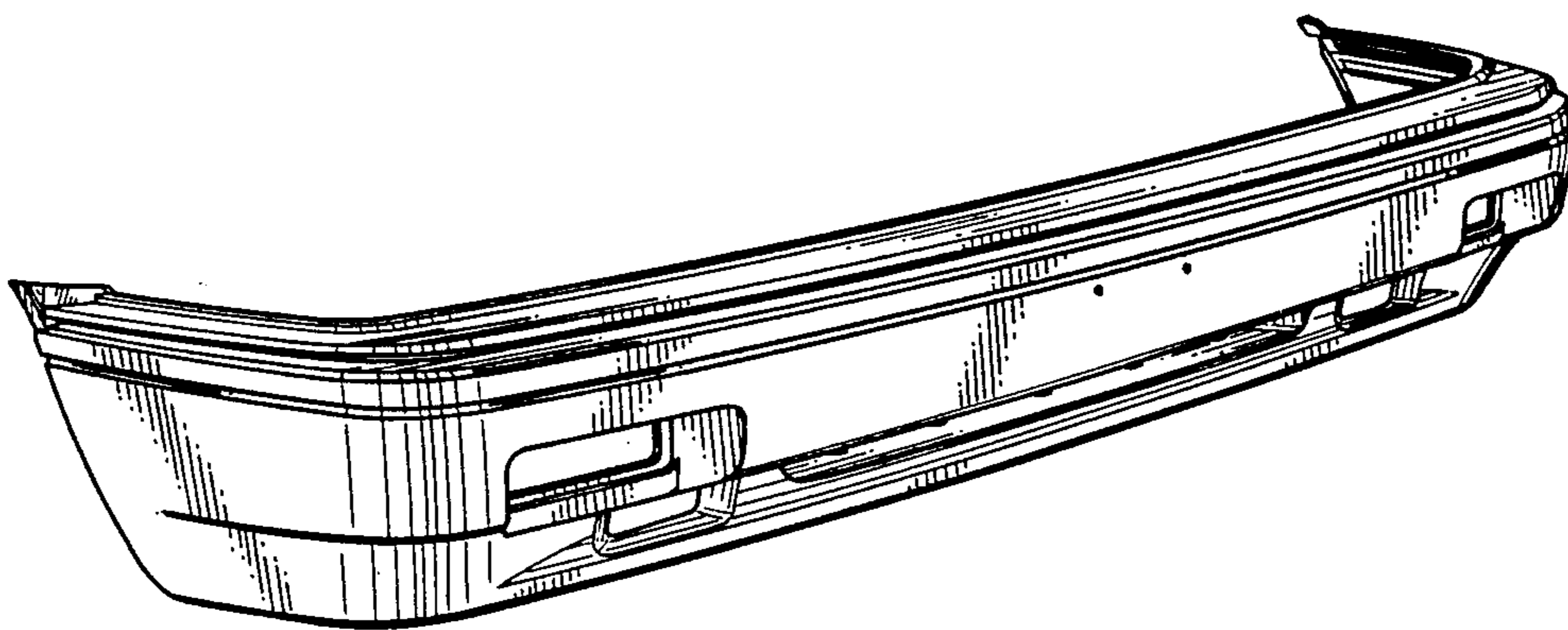

Fig. 1

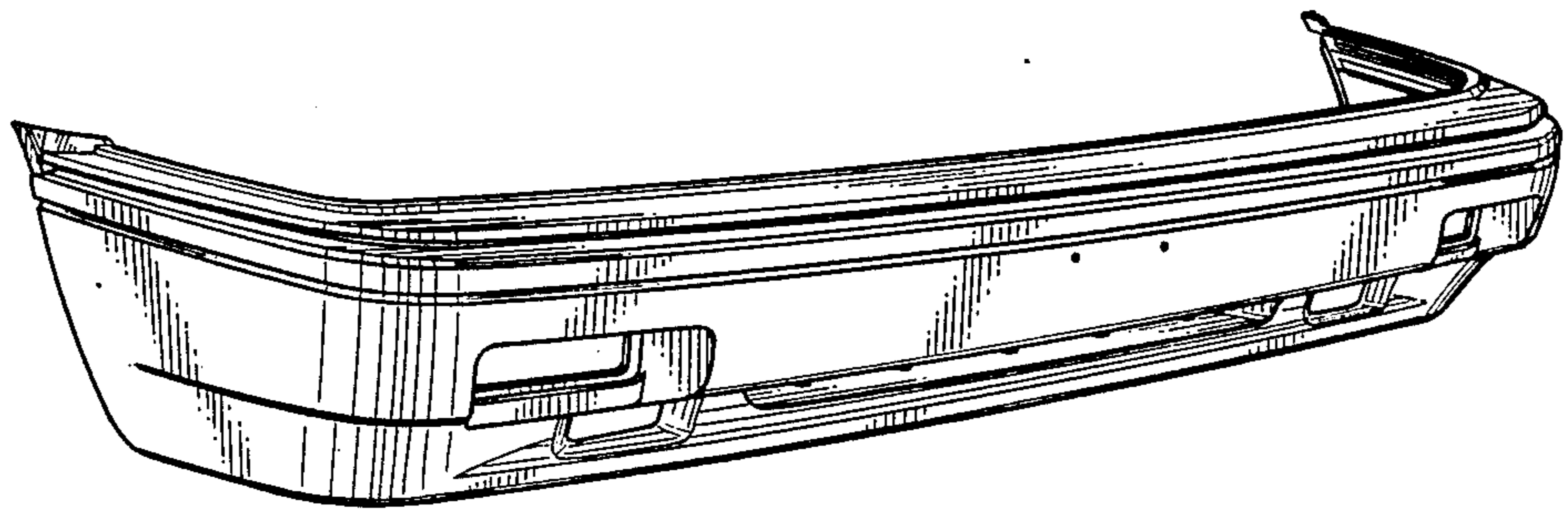

Fig. 2

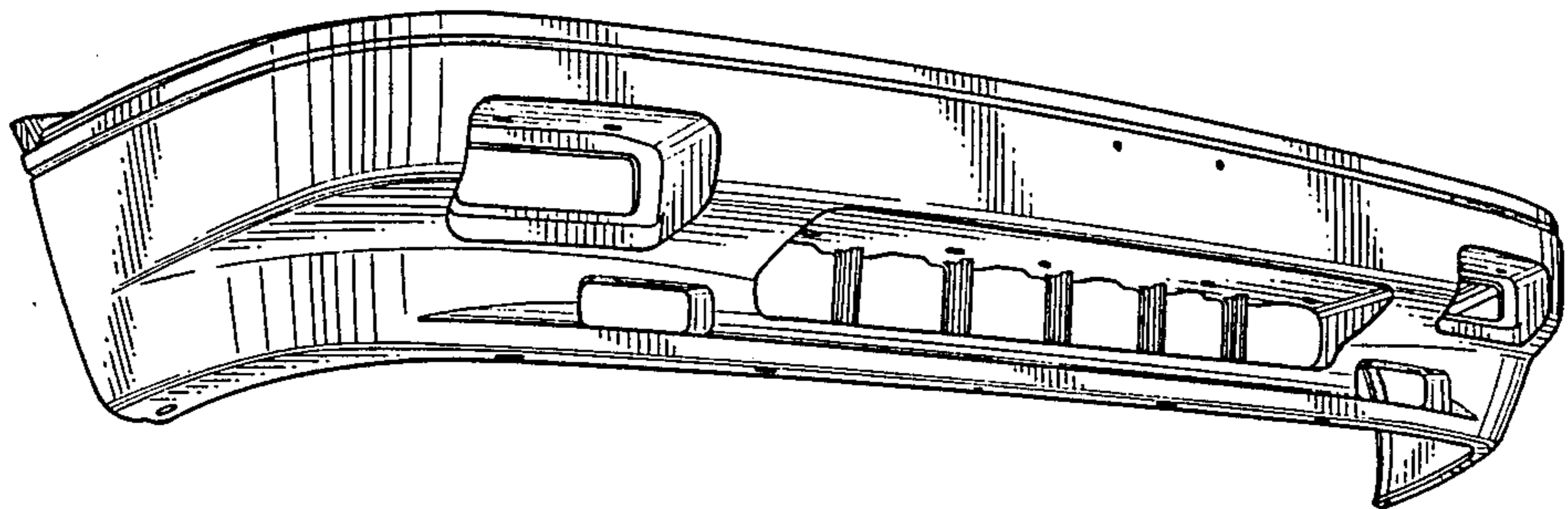

Fig. 3

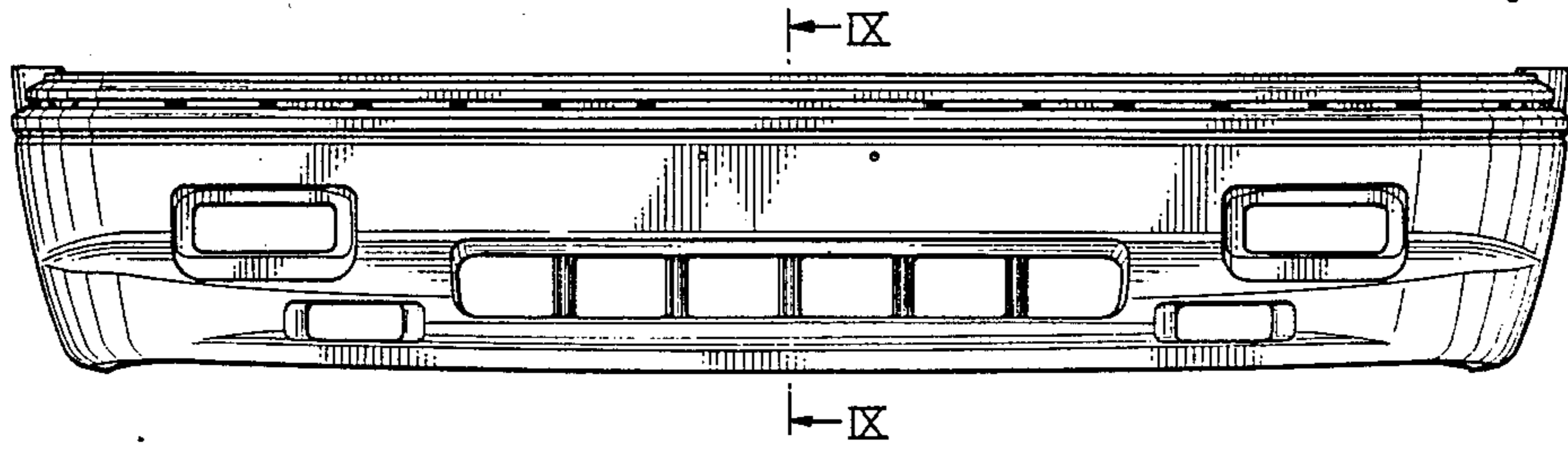

Fig. 4

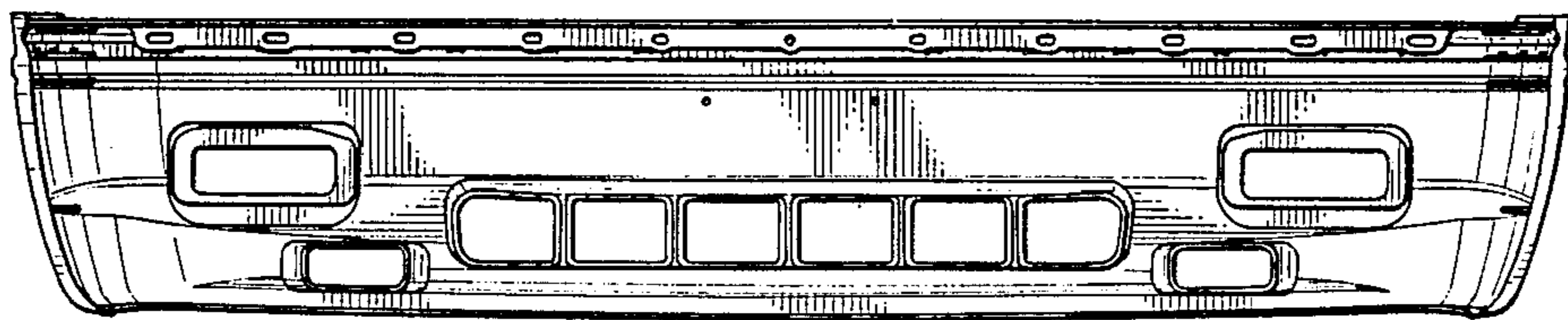

Fig. 5

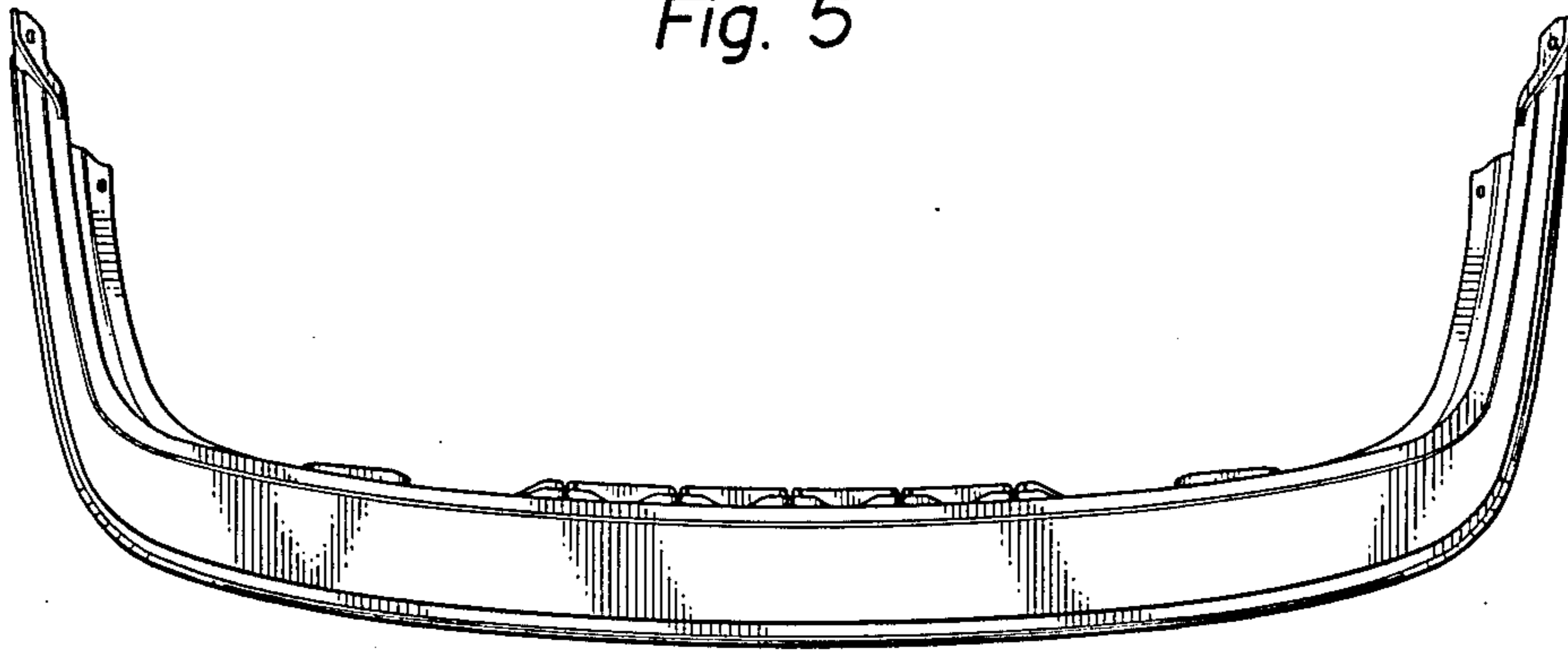

Fig. 6

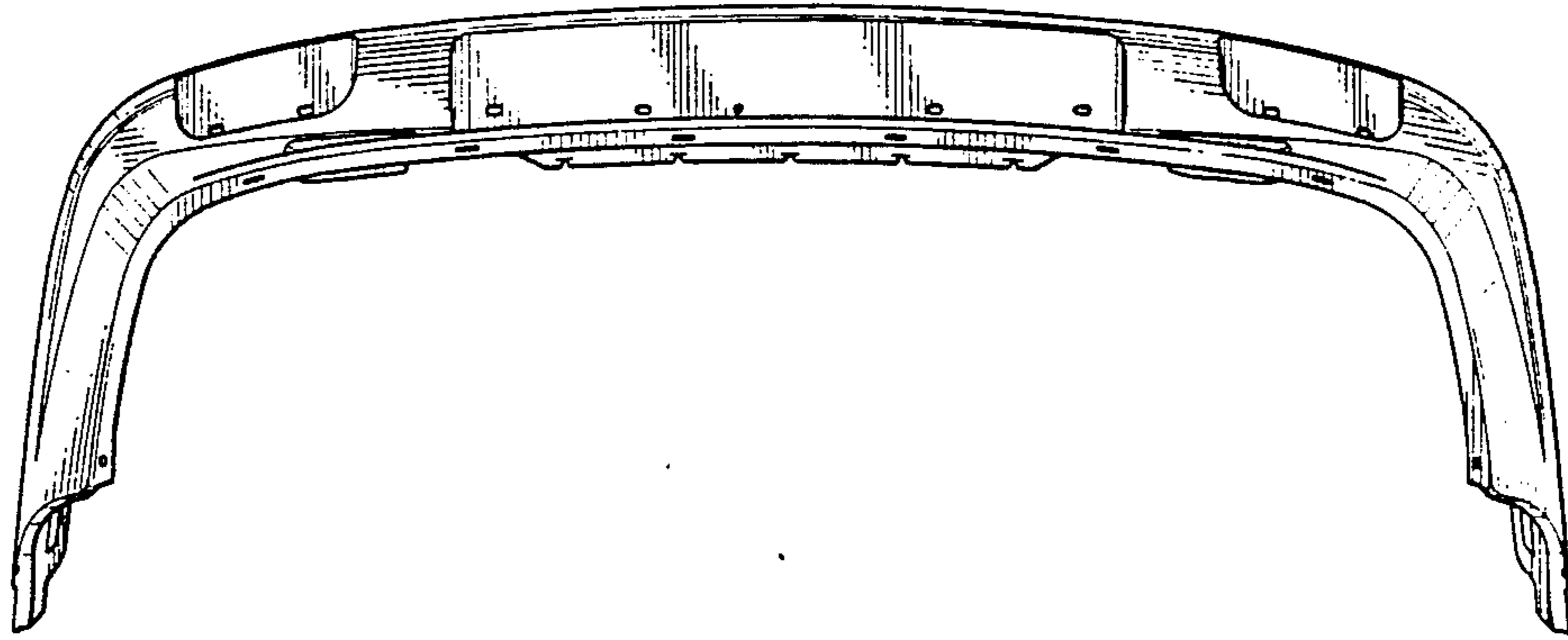

Fig. 7

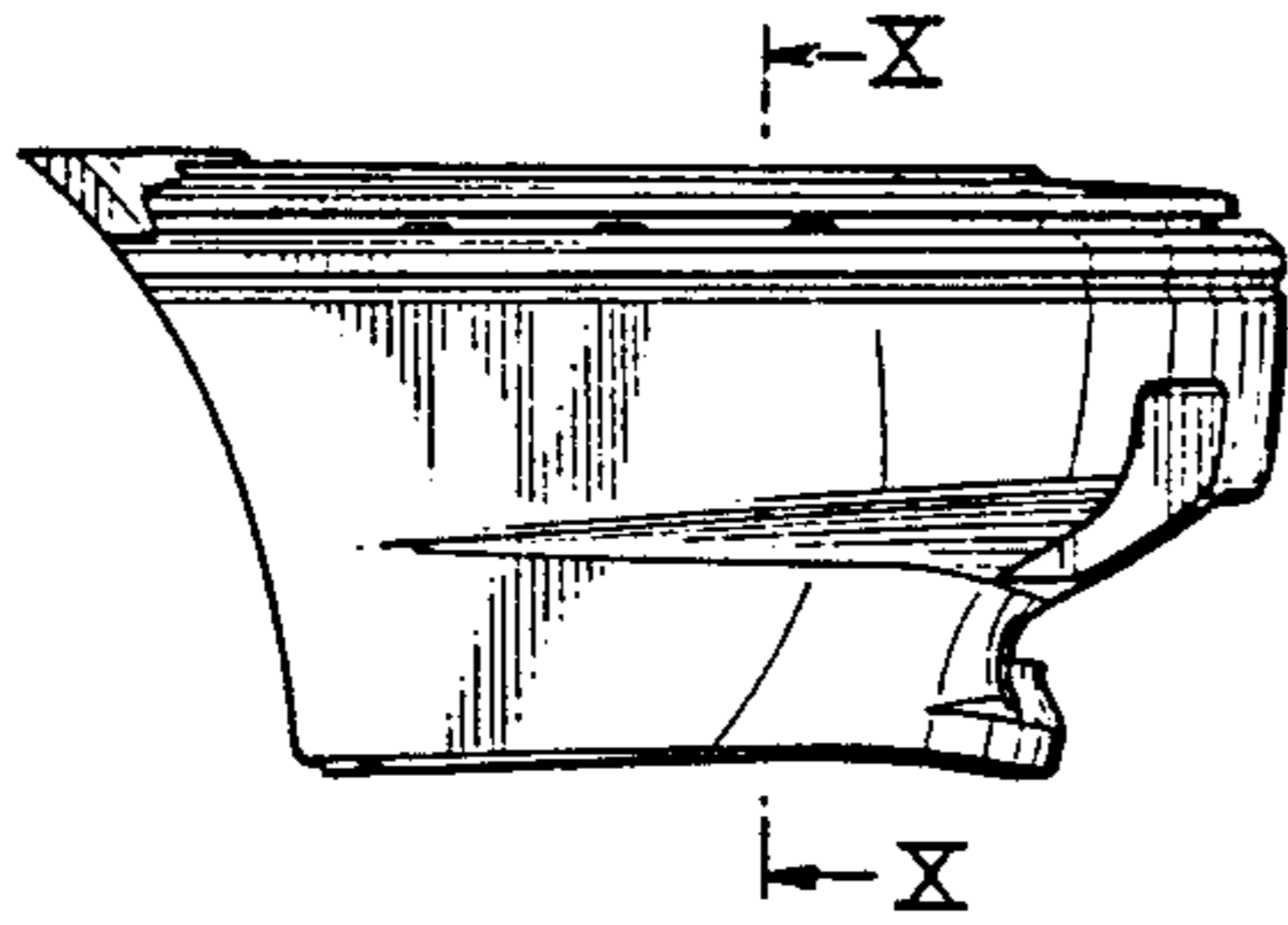

Fig. 8

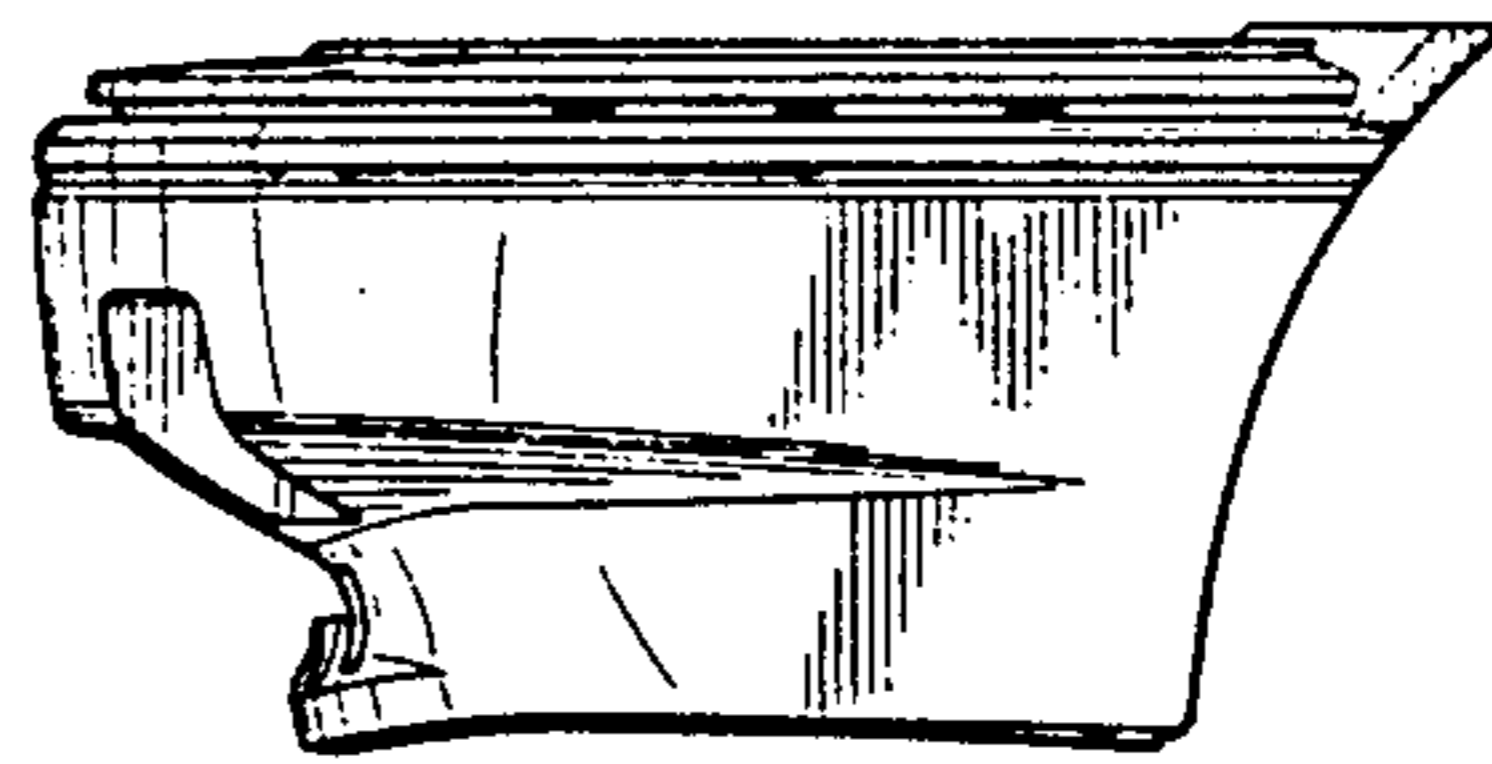

Fig. 9

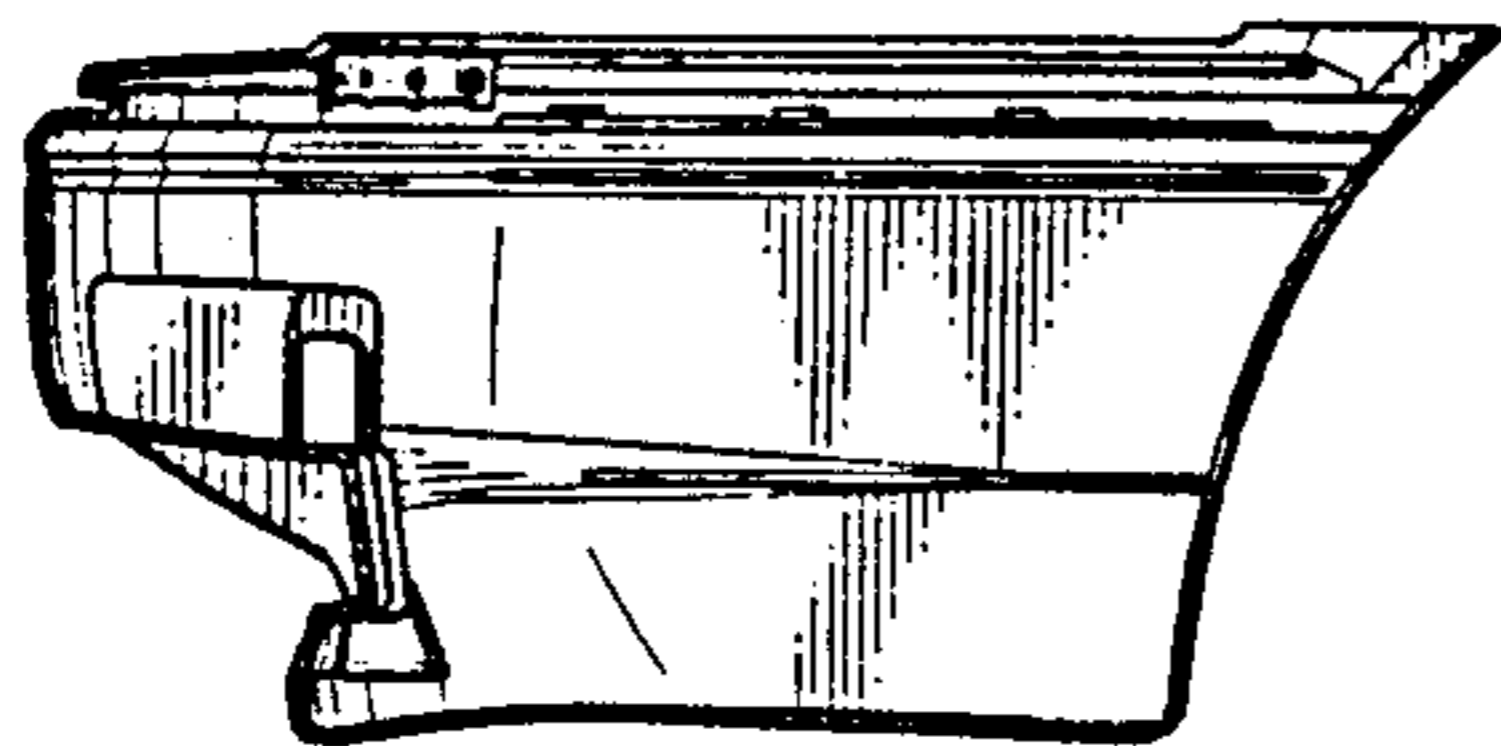

Fig. 10

