

[54] CAN HOLDER FOR AN AUTOMOBILE

[75] Inventor: Atsuya Mizukami, Tokyo, Japan

[73] Assignee: Tanaka Manufacturing Company Limited, Tokyo, Japan

[**] Term: 14 Years

[21] Appl. No.: 72,237

[22] Filed: Jul. 10, 1987

[30] Foreign Application Priority Data

Feb. 2, 1987 [JP] Japan 62-3734
 [52] U.S. Cl. D7/619
 [58] Field of Search D7/70, 71; 211/74, 81;
 248/346.1, 311.2, 314, 315; 220/96

[56] References Cited

U.S. PATENT DOCUMENTS

2,649,270 8/1953 Franks 248/311.2
 2,754,078 7/1956 Koger et al. 248/311.2
 4,828,211 5/1989 McConnell et al. D7/70 X

Primary Examiner—Bernard Ansher
 Assistant Examiner—Terry A. Pfeffer
 Attorney, Agent, or Firm—Amster, Rothstein & Ebenstein

[57] CLAIM

The ornamental design for a can holder for an automobile, as shown and described.

DESCRIPTION

FIG. 1 is a top, front, left side perspective view of a can holder for an automobile showing my new design;
 FIG. 2 is a top, front, left side perspective view thereof in a partially closed position;
 FIG. 3 is a front elevational view thereof;
 FIG. 4 is a rear elevational view thereof;
 FIG. 5 is a top plan view thereof;
 FIG. 6 is a bottom plan view thereof;
 FIG. 7 is a right side elevational view thereof;
 FIG. 8 is a top plan view thereof in a closed position;
 FIG. 9 is a front elevational view thereof in a closed position; and
 FIG. 10 is a right side elevational view thereof in a closed position.

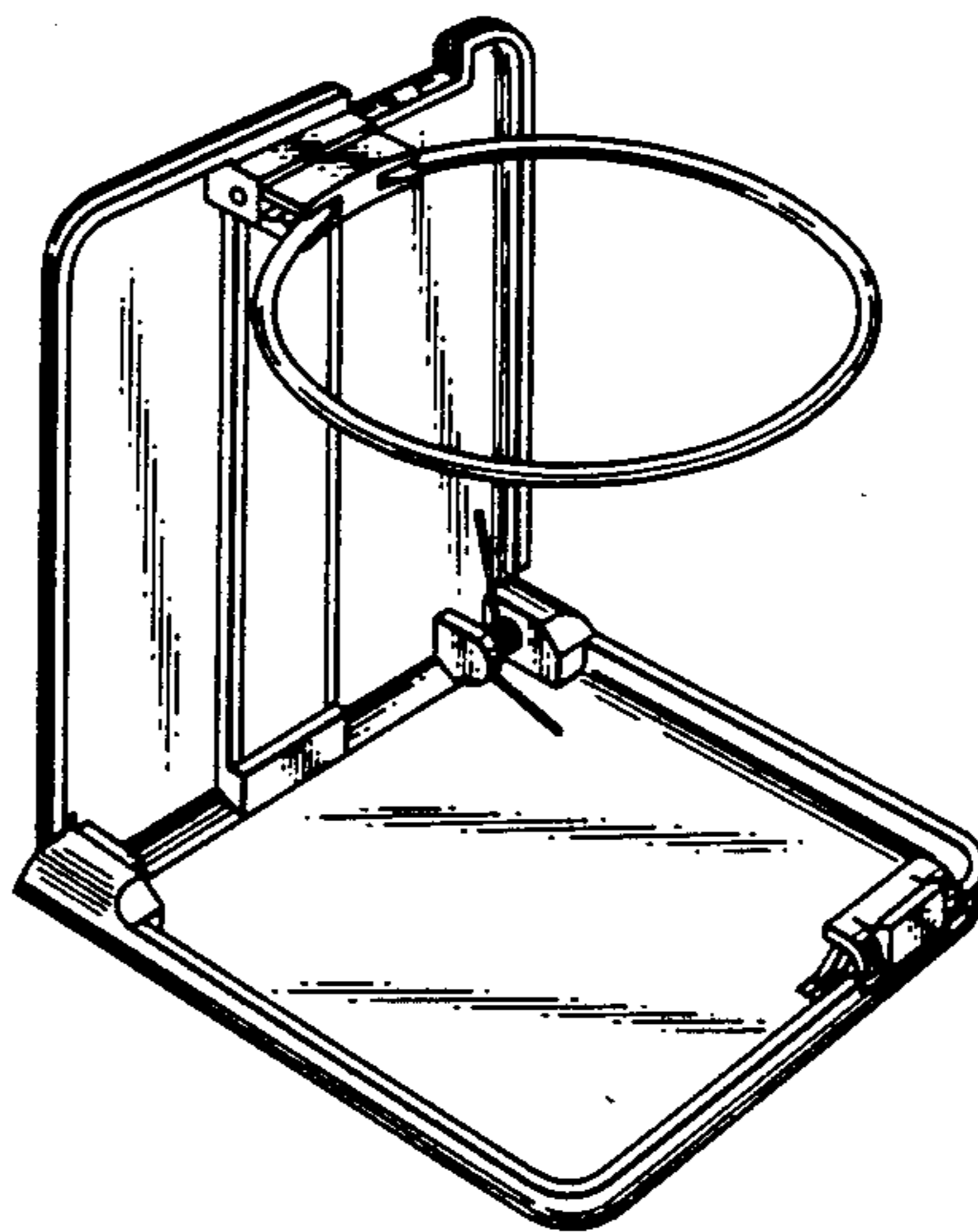

FIG. 1

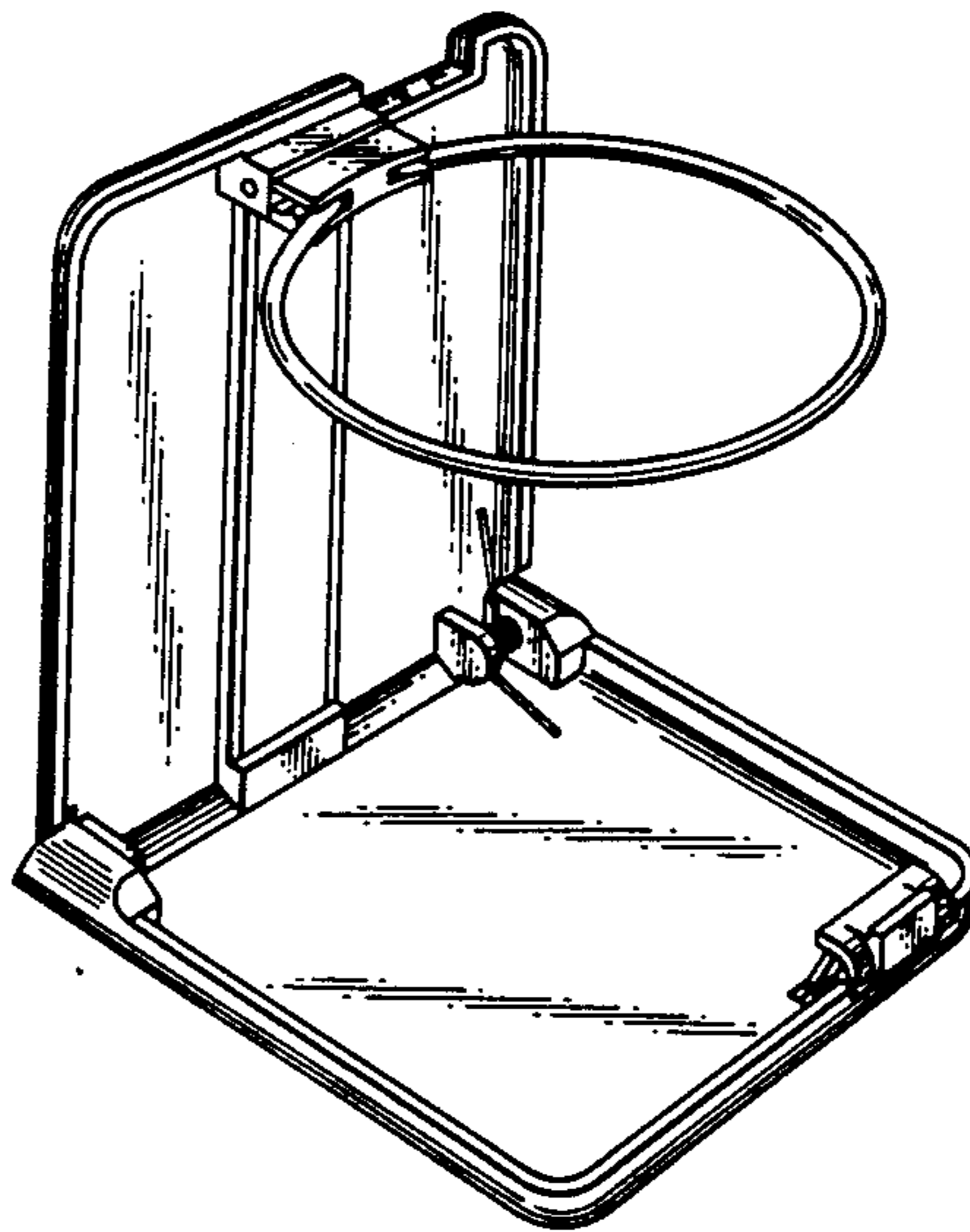

FIG. 2

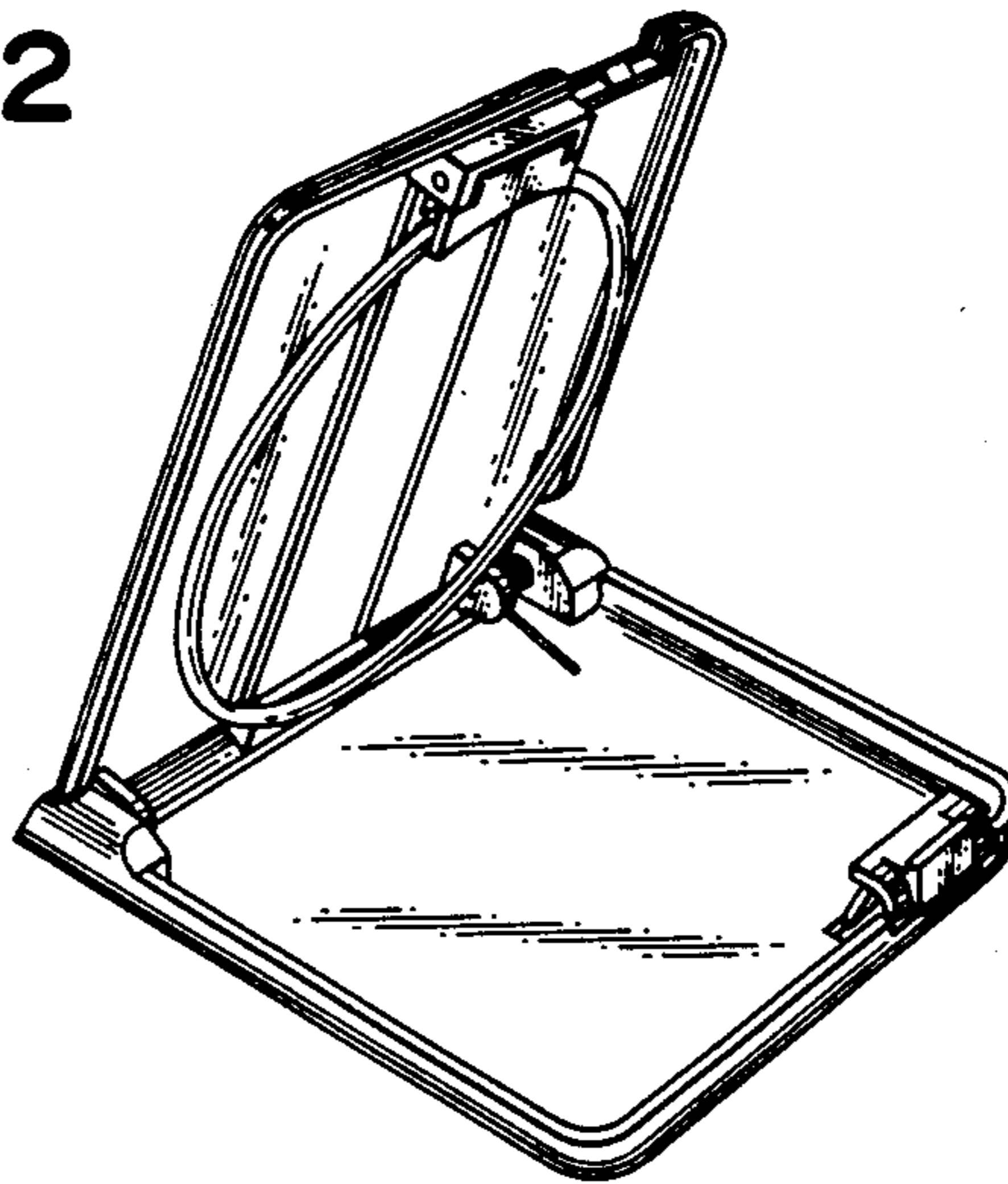

FIG. 3

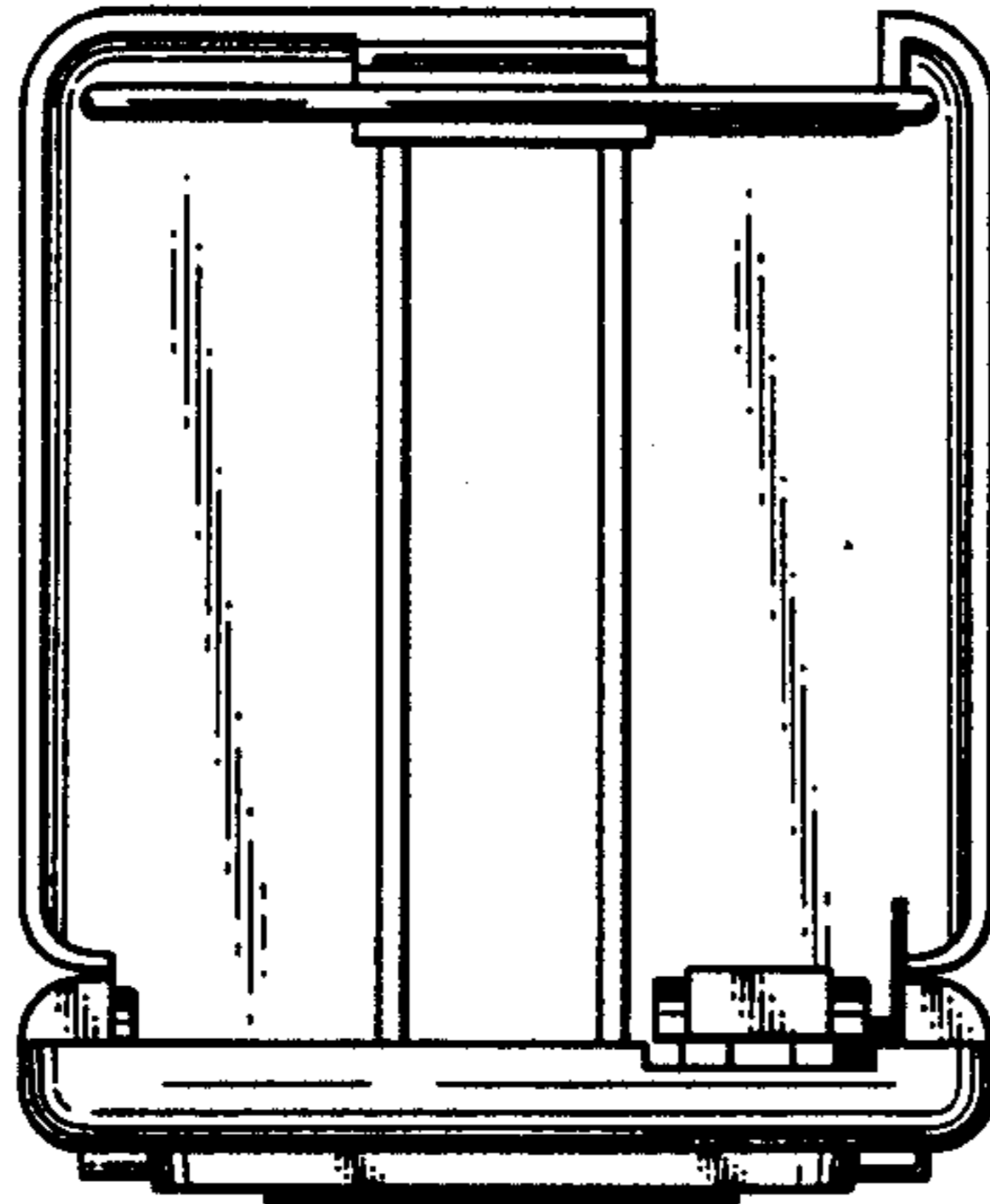

FIG. 4

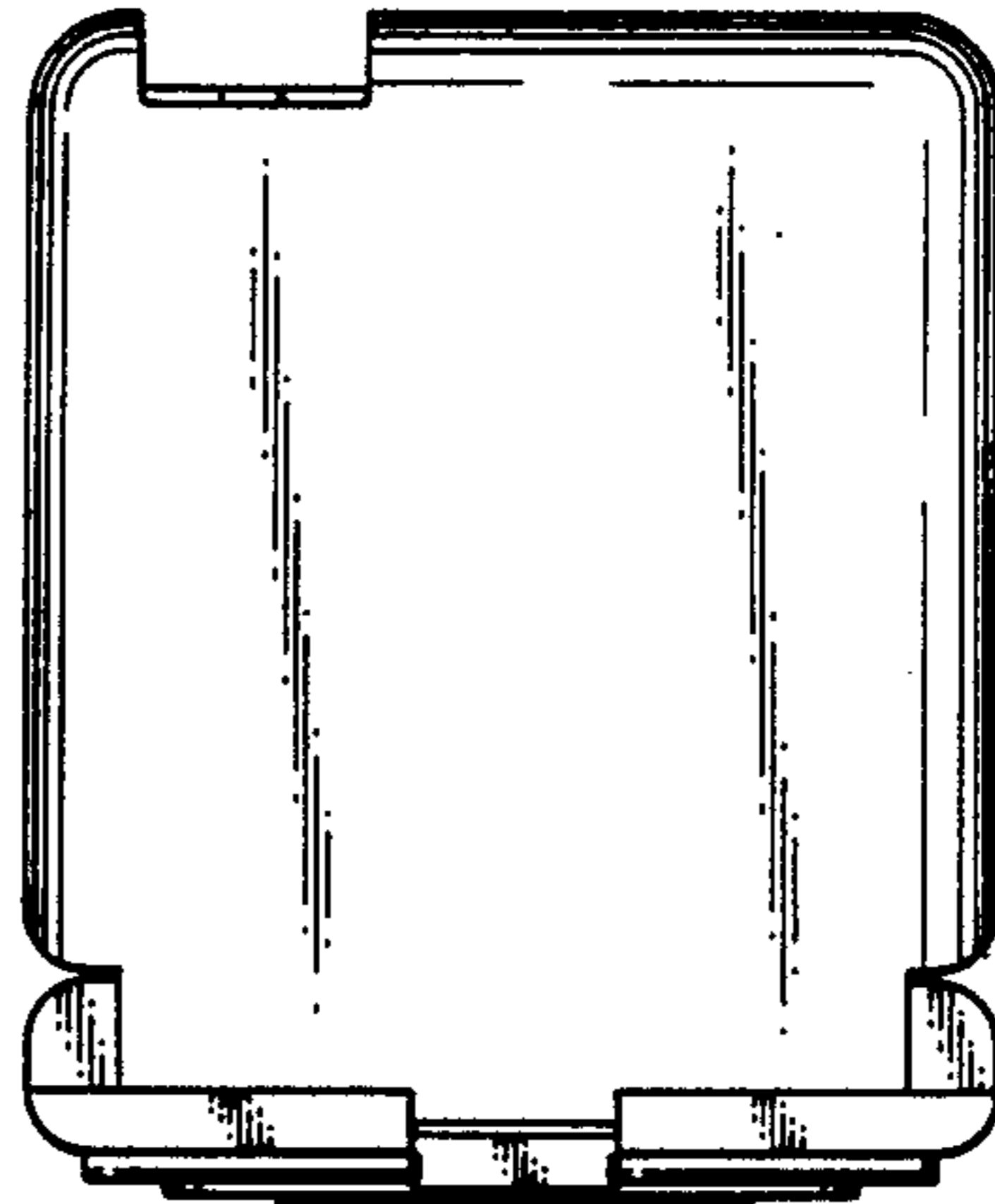

FIG. 5

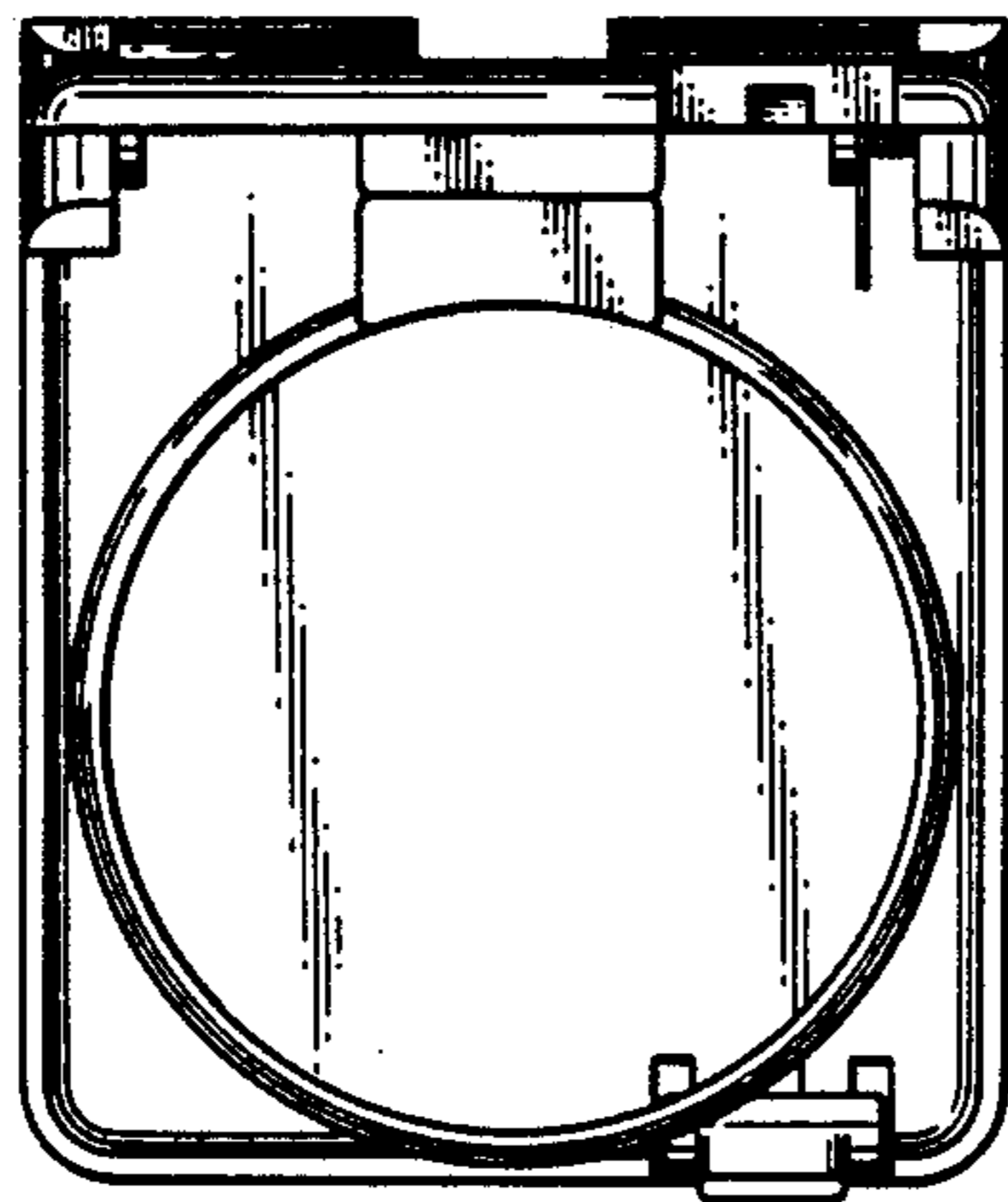

FIG. 6

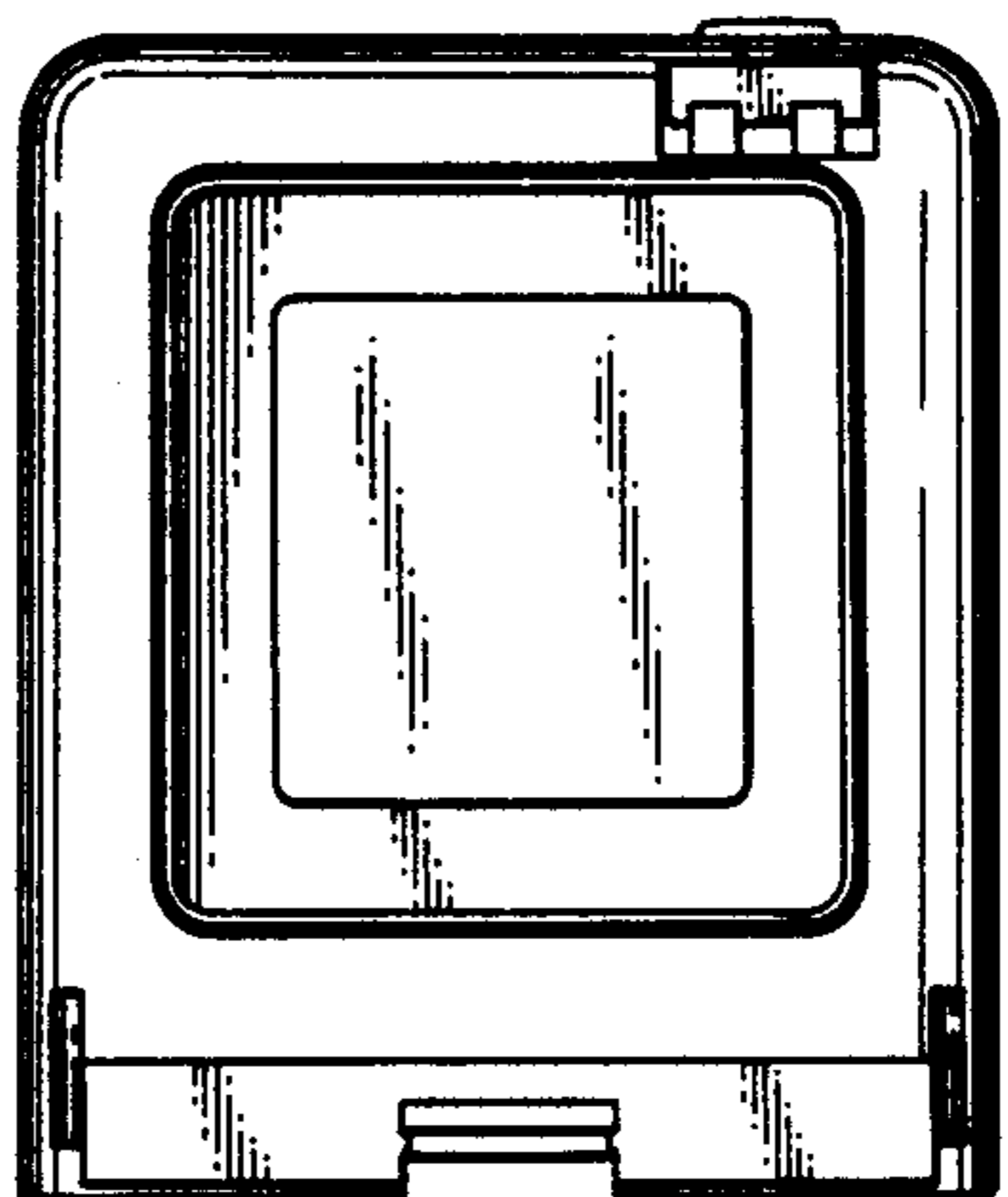

FIG. 7

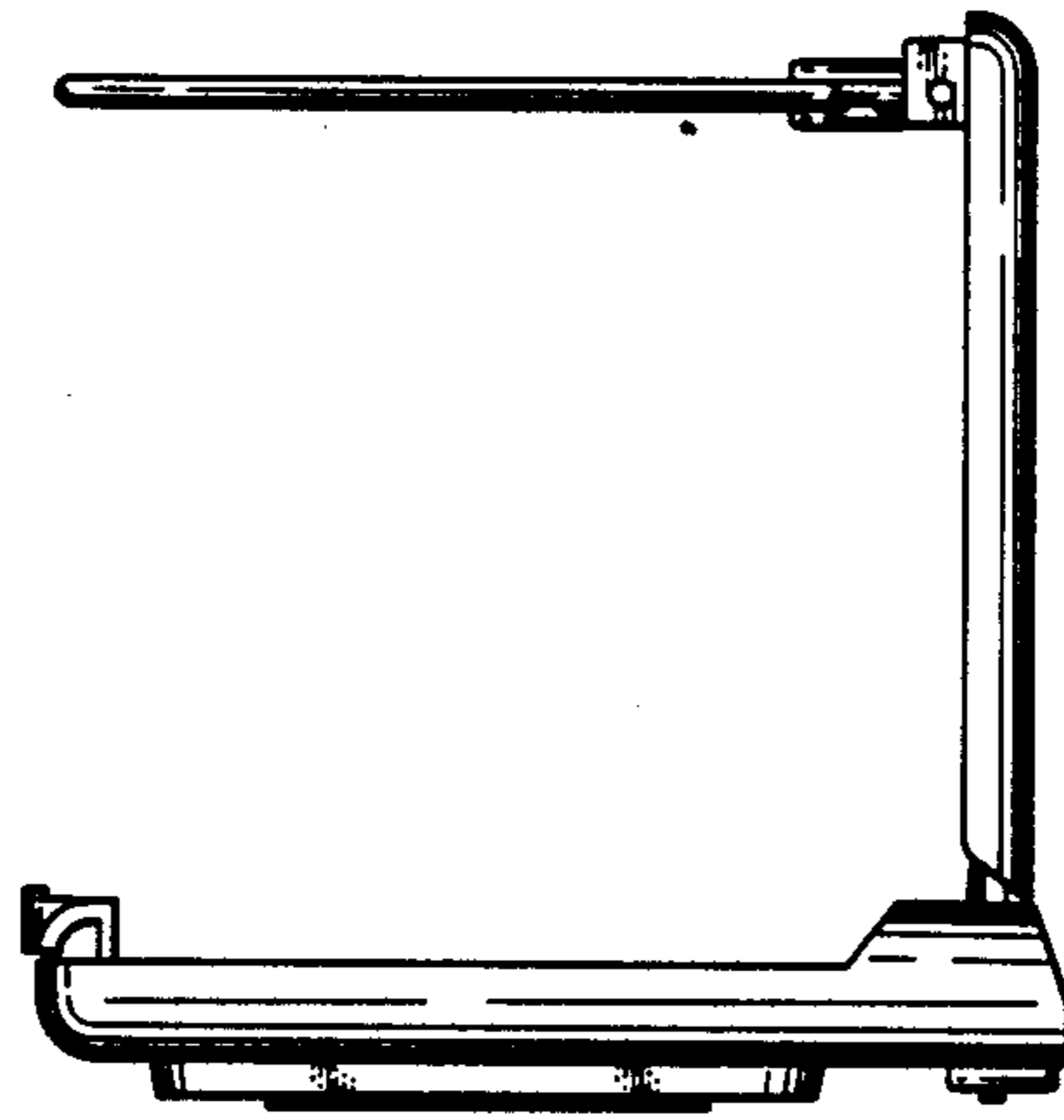

FIG. 8

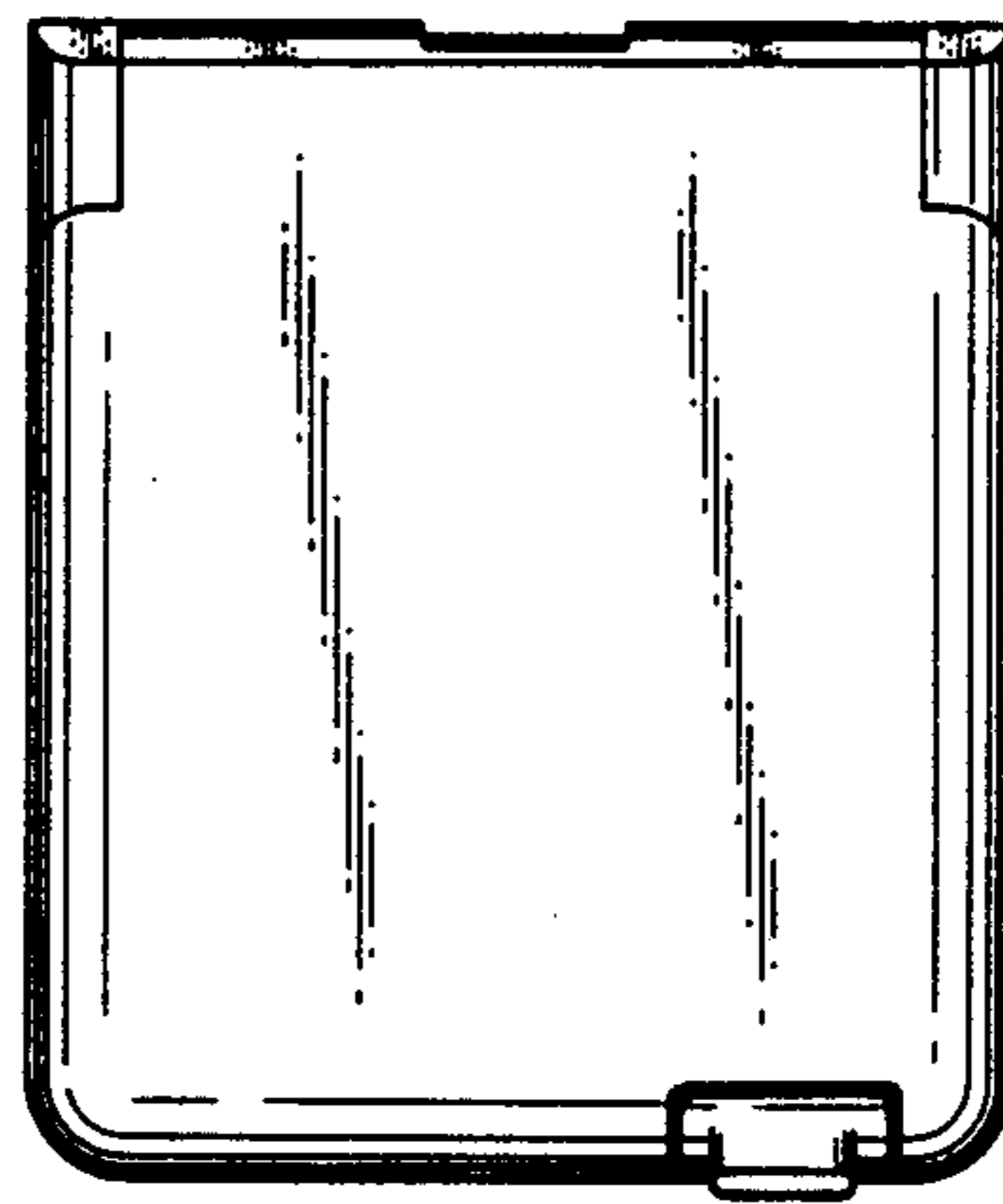

FIG. 9



FIG. 10

