

[54] BATTERY CART

[76] Inventor: Gary G. Gallagher, 4300 Estrella Rd., San Miguel, Calif. 93451

[\*\*] Term: 14 Years

[21] Appl. No.: 108,977

[22] Filed: Oct. 16, 1987

[52] U.S. Cl. .... D34/17; D34/12

[58] Field of Search ..... D34/12, 17, 20, 21; 280/47.35, 651, 47.34, 79.1 A, 79.1 R

[56] References Cited

U.S. PATENT DOCUMENTS

3,388,943	6/1968	Clement .....	280/47.34
4,020,959	5/1977	Livesay .....	280/47.35
4,165,088	8/1979	Nelson .....	280/47.35
4,512,591	4/1985	Plante .....	280/47.35

FOREIGN PATENT DOCUMENTS

1071492 11/1957 Fed. Rep. of Germany ..... 280/651

Primary Examiner—James M. Gandy

Assistant Examiner—Kay H. Chin

Attorney, Agent, or Firm—Daniel C. McKown

[57] CLAIM

The ornamental design for a battery cart, as shown and described.

DESCRIPTION

FIG. 1 is a front perspective view of a battery cart showing my new design;

FIG. 2 is a left side elevational view thereof, the right side elevational view being a mirror image of that shown;

FIG. 3 is a front elevational view thereof;

FIG. 4 is a rear elevational view thereof;

FIG. 5 is a top plan view thereof; and

FIG. 6 is a bottom plan view thereof.

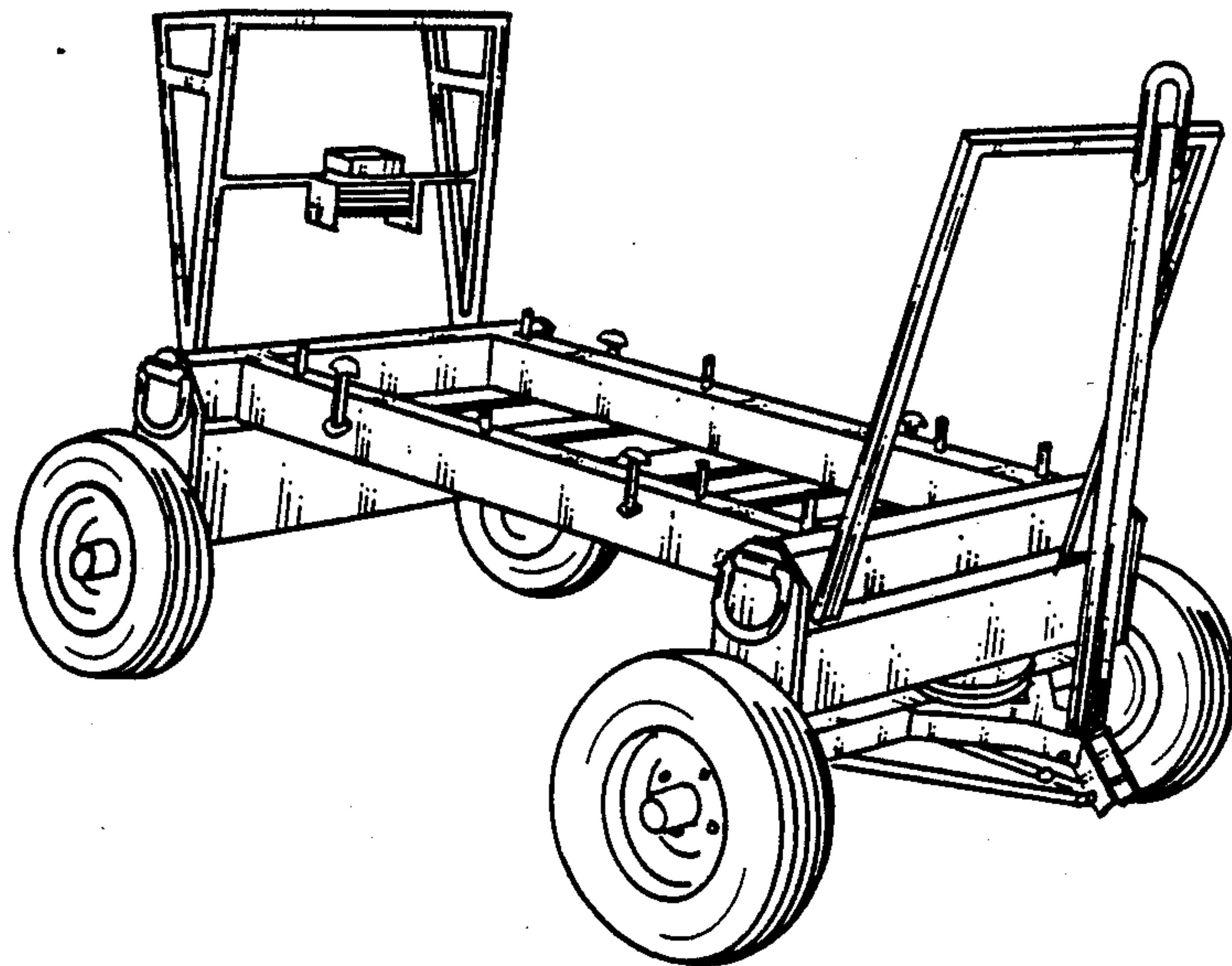

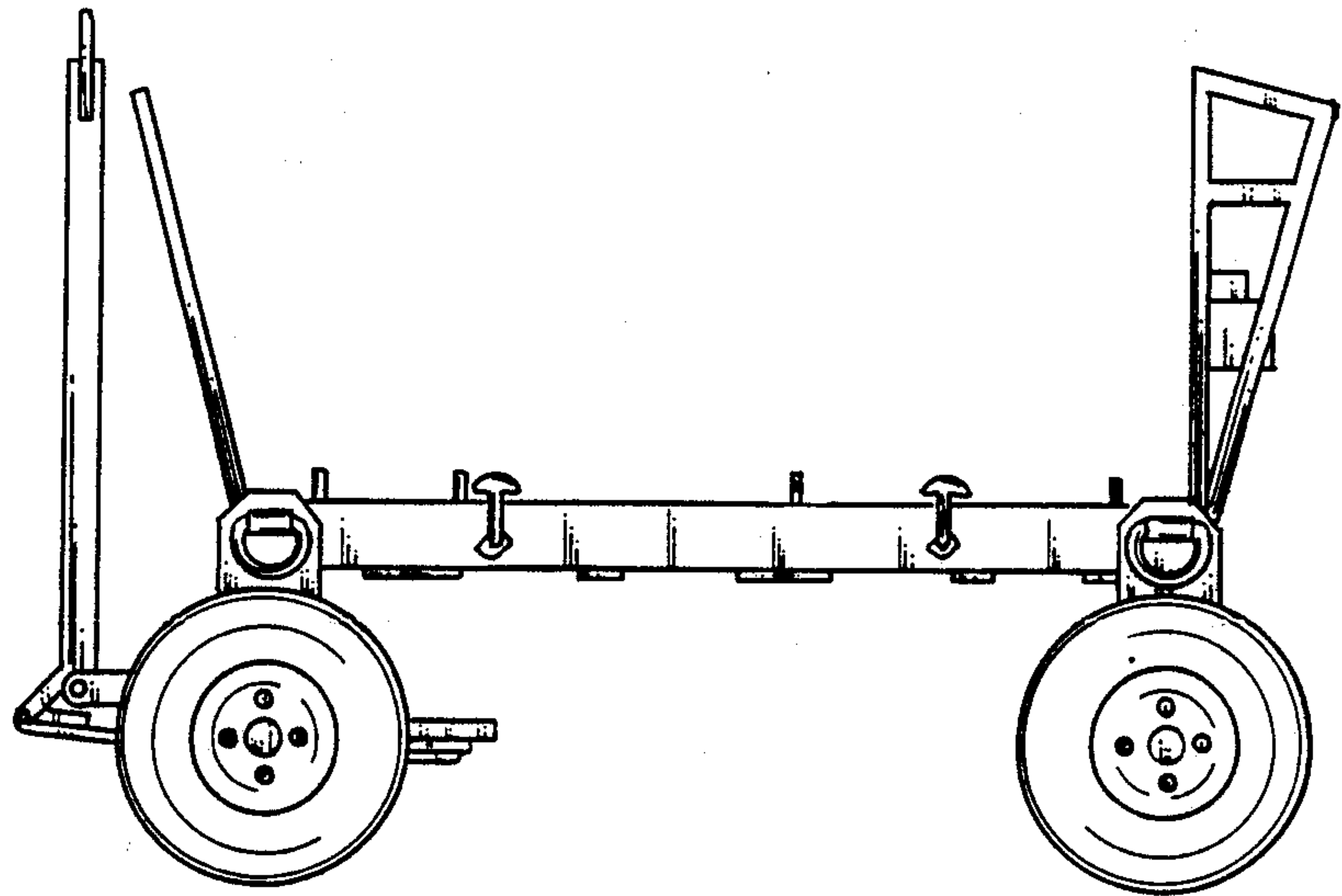

Fig. 2

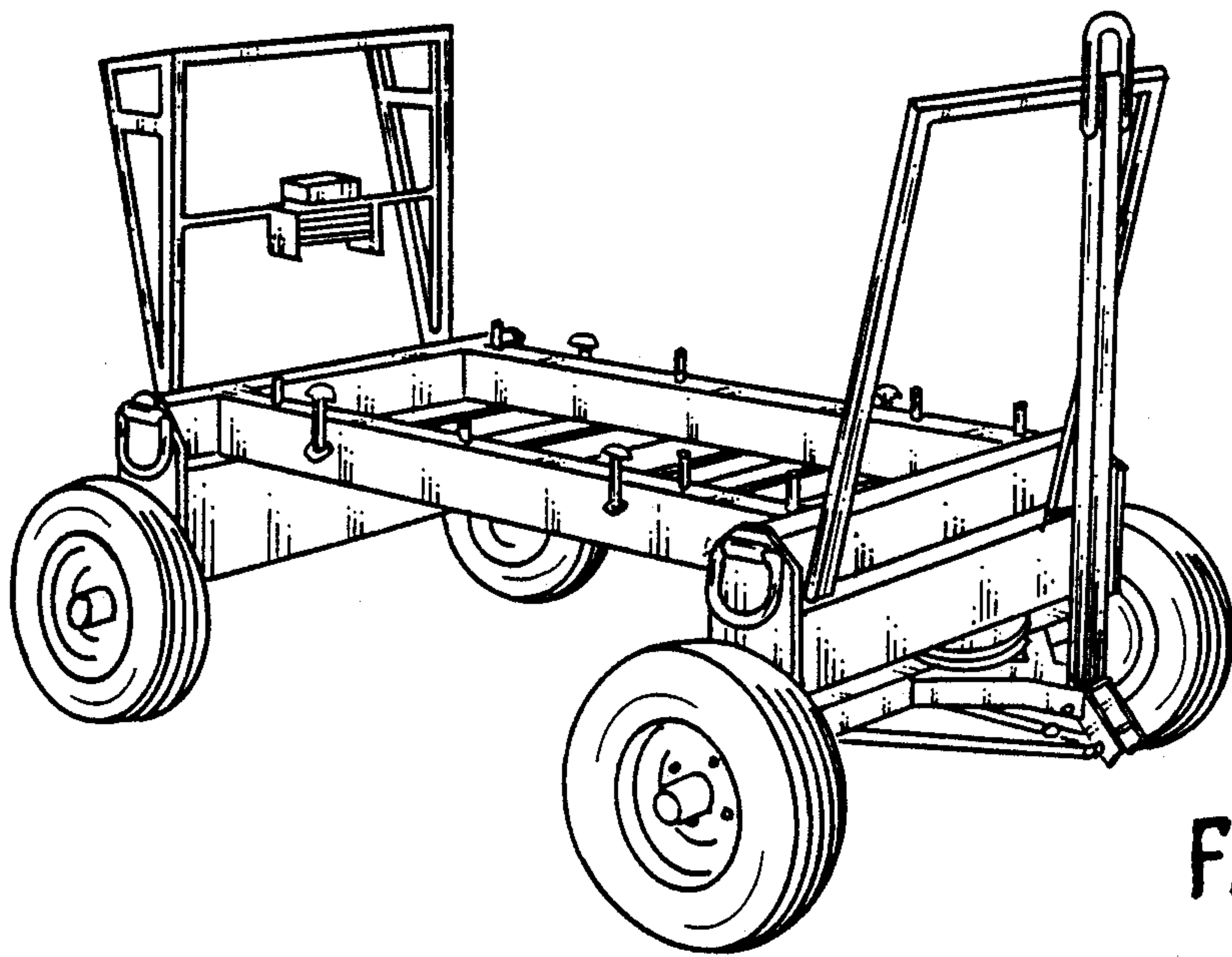

Fig. 1

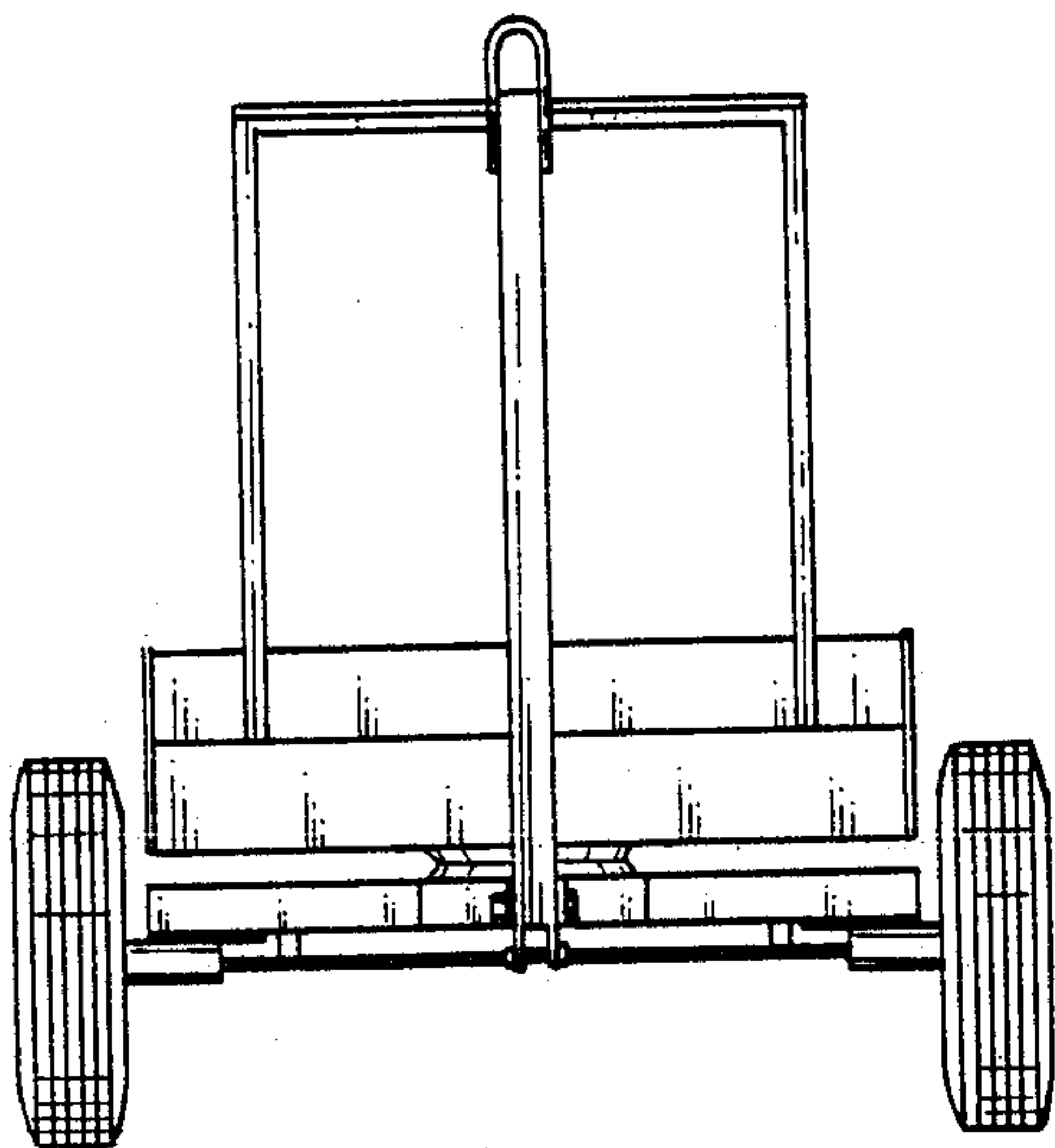

Fig. 3

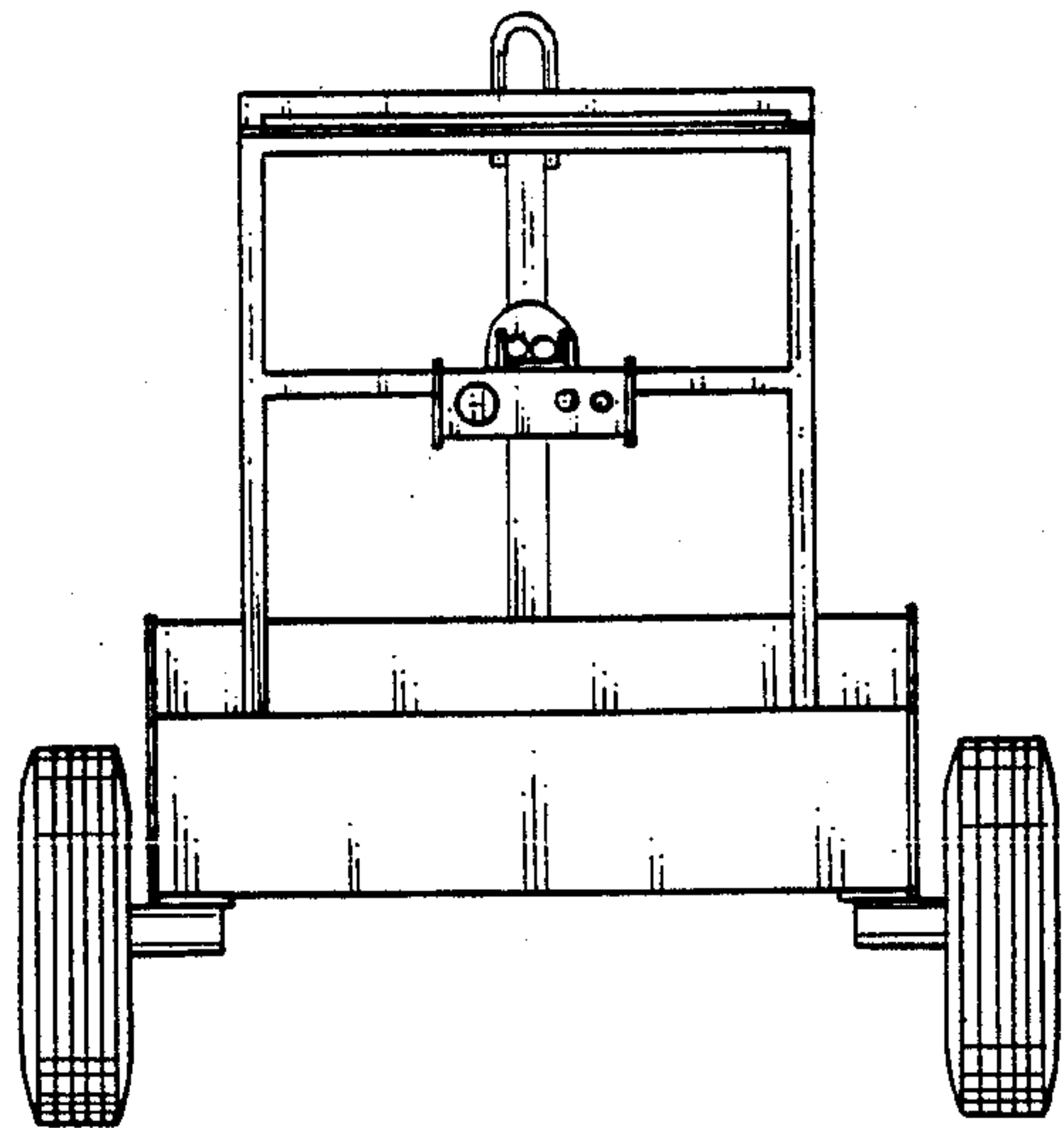

Fig. 4

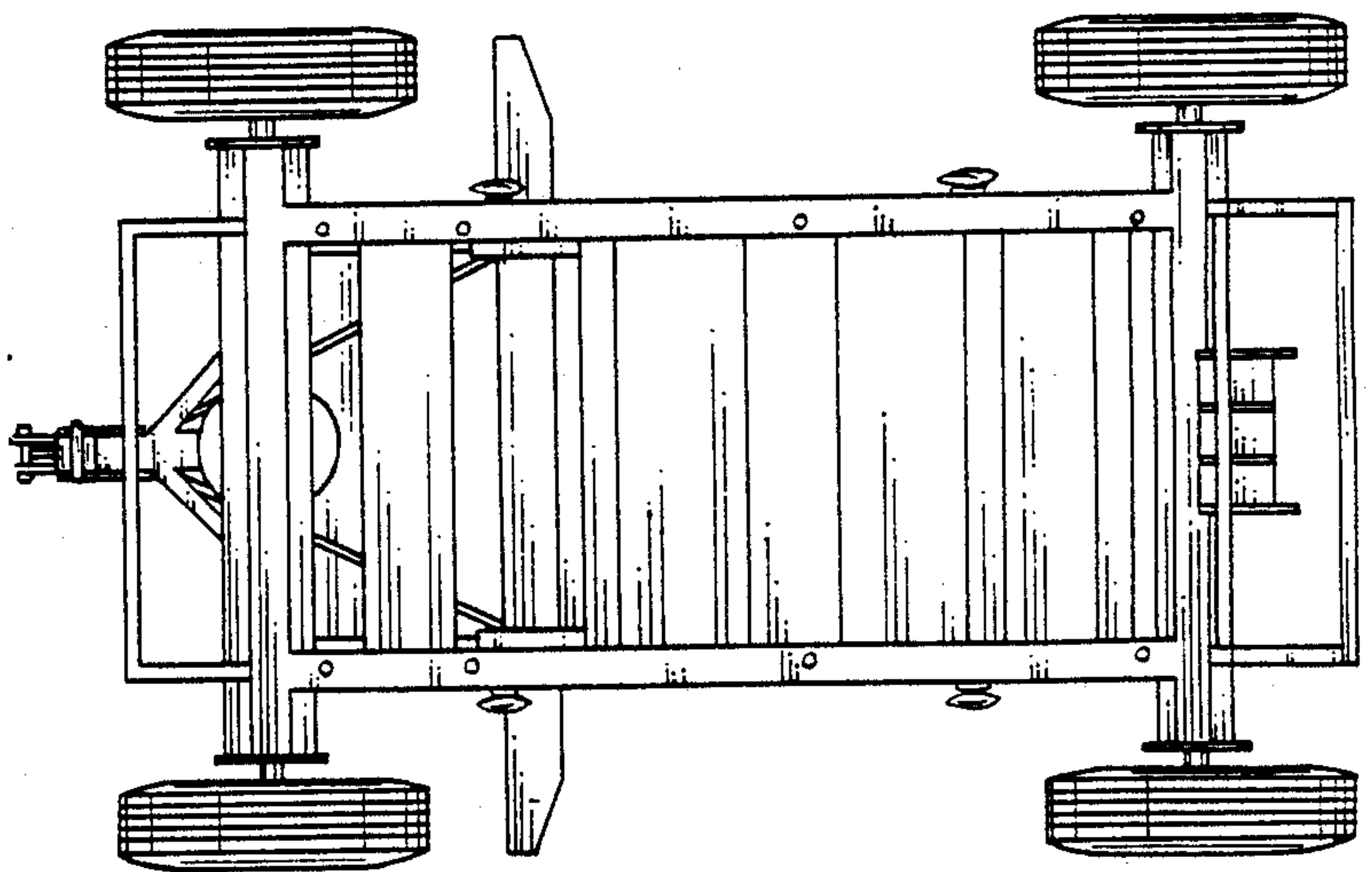

Fig. 5

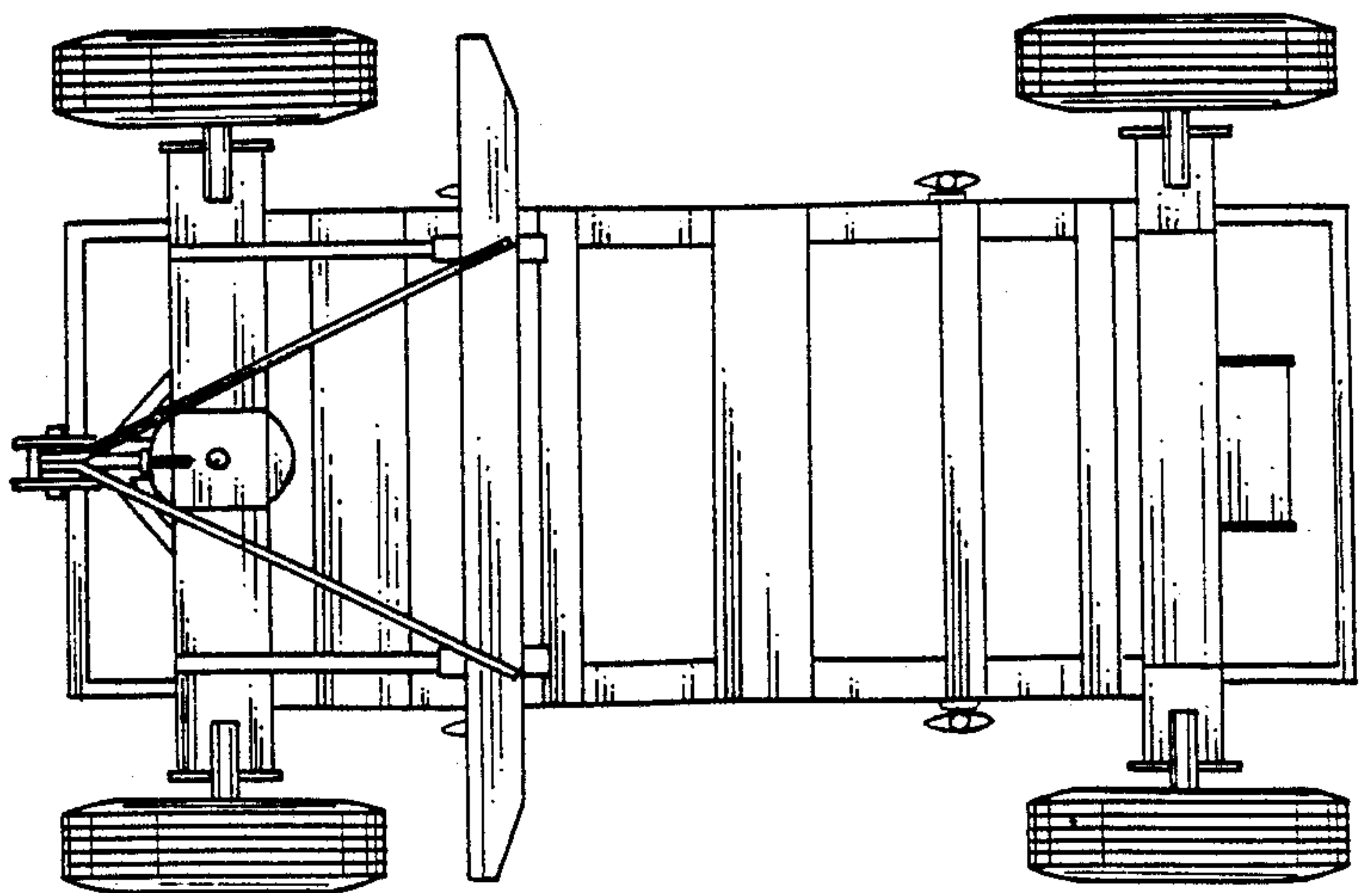

Fig. 6