

United States Patent [19]

Hemmingsen

[11] Patent Number: Des. 307,150

[45] Date of Patent: ** Apr. 10, 1990

[54] SUPPORTING ARM FOR A TIRE HANDLING ROBOT

[76] Inventor: Karl R. Hemmingsen,
Hojmarksvanget 77, DK-8600
Silkeborg, Denmark

[**] Term: 14 Years

[21] Appl. No.: 92,697

[22] Filed: Sep. 3, 1987

[52] U.S. Cl. D15/199; D15/138

[58] Field of Search D15/199, 138; 414/563,
414/428, 426

[56] **References Cited**

U.S. PATENT DOCUMENTS

D. 277,866 3/1985 Hall D15/199
D. 279,785 7/1985 Vaughan D15/138 X
3,735,882 5/1973 Reznicek 414/428

3,937,343 2/1976 Spulak 414/428
4,216,941 8/1980 Little 414/563 X
4,401,405 8/1983 Ealet 414/428
4,634,337 1/1987 Hamman 414/563
4,669,417 6/1987 Pederson et al. D15/199 X
4,678,392 7/1987 Capers et al. 414/563
4,741,661 5/1988 Carey 414/563

Primary Examiner—Nelson C. Holtje
Assistant Examiner—Jeffrey Ash
Attorney, Agent, or Firm—Antonelli, Terry & Wands

[57] **CLAIM**

The ornamental design for a supporting arm for a tire handling robot, as shown and described.

DESCRIPTION

FIG. 1 is a front, top and right side perspective view of a support arm for a tire handling robot showing my new design; and

FIG. 2 is a rear, bottom, and right side perspective view thereof, the left side being conventional in appearance.

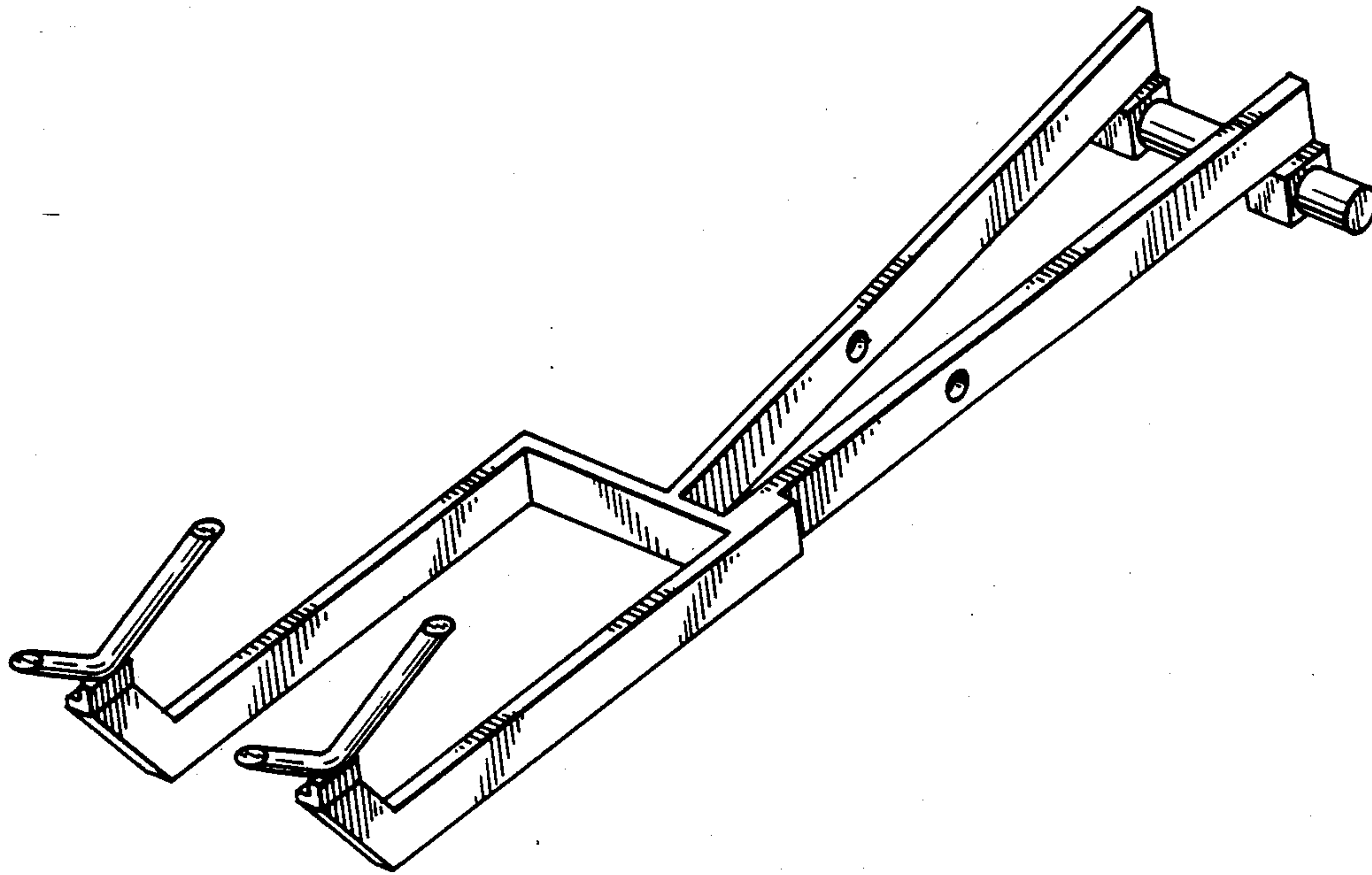

FIG. 1

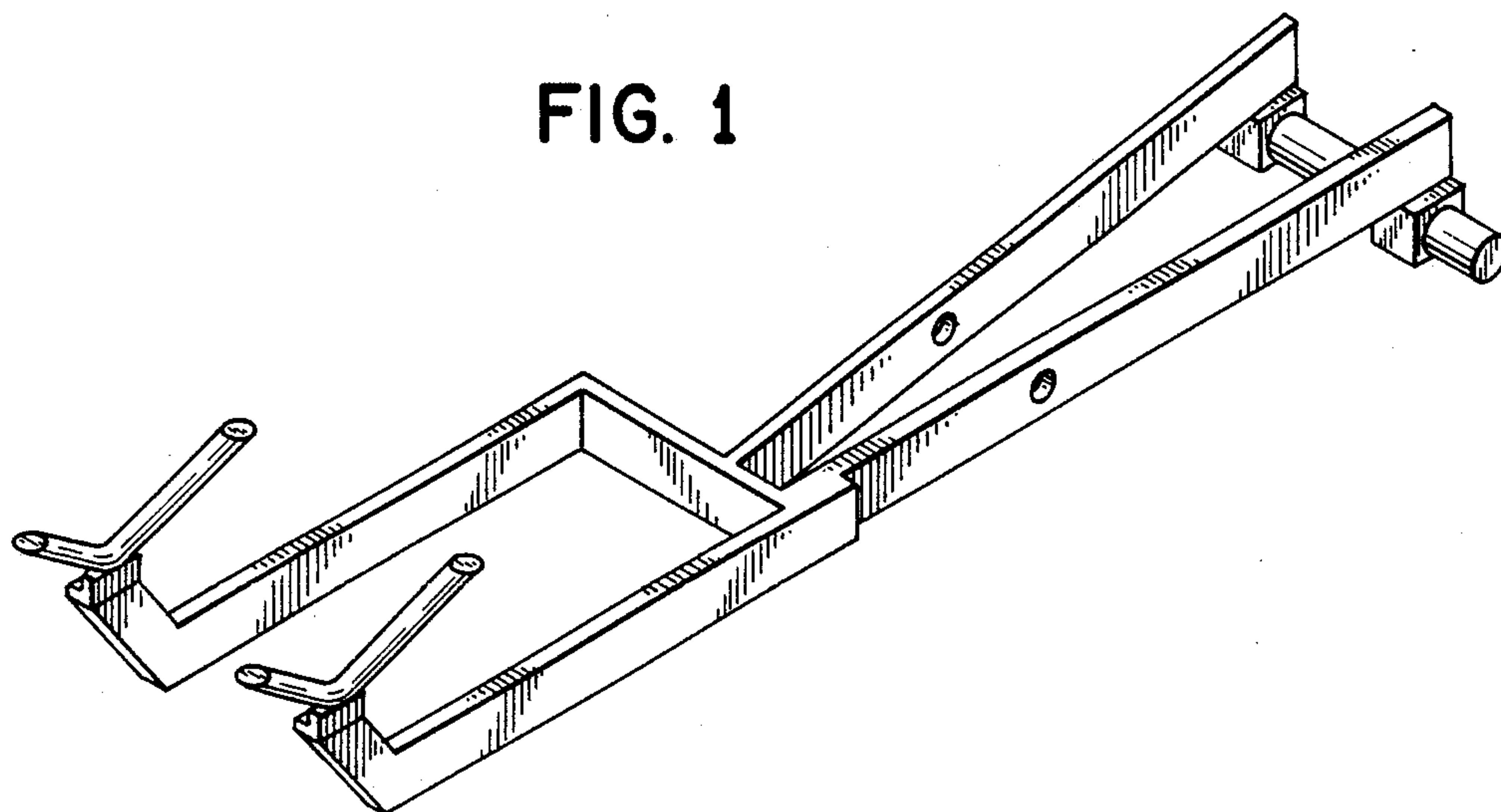

FIG. 2

