

[54] INTERNAL COMBUSTION ENGINE

[75] Inventors: Koichi Sasaki; Masahiko Kagawa, both of Wako, Japan

[73] Assignee: Honda Giken Kogyo Kabushiki Kaisha, Tokyo, Japan

[\*\*] Term: 14 Years

[21] Appl. No.: 81,137

[22] Filed: Aug. 3, 1987

[30] Foreign Application Priority Data

Feb. 3, 1987 [JP] Japan ..... 62-3841

[52] U.S. Cl. .... D15/1

[58] Field of Search ..... D15/1, 3; 123/22, 41, 123/34, 52 R, 56 A, 56 B, 56 BA, 56 BC, 58 R, 311, 198 E

[56] References Cited

U.S. PATENT DOCUMENTS

D. 239,329 3/1976 Schramm ..... D15/1

D. 282,071	1/1986	Nakamura	.....	D15/1
D. 284,862	7/1986	Iida	.....	D15/1
D. 293,114	12/1987	Brogdon	.....	D15/1
D. 294,832	3/1988	Itou et al.	.....	D15/1
4,429,668	2/1984	Nakagawa	.....	123/56 BA

Primary Examiner—Wallace R. Burke  
Assistant Examiner—Brian N. Vinson  
Attorney, Agent, or Firm—Wenderoth, Lind & Ponack

[57] CLAIM

The ornamental design for an internal combustion engine, as shown.

DESCRIPTION

FIG. 1 is a front elevational view of an internal combustion engine showing our new design;  
FIG. 2 is a rear elevational view thereof;  
FIG. 3 is a right side elevational view thereof;  
FIG. 4 is a left side elevational view thereof;  
FIG. 5 is a top plan view thereof;  
FIG. 6 is a bottom plan view thereof, and  
FIG. 7 is a right side perspective view thereof.

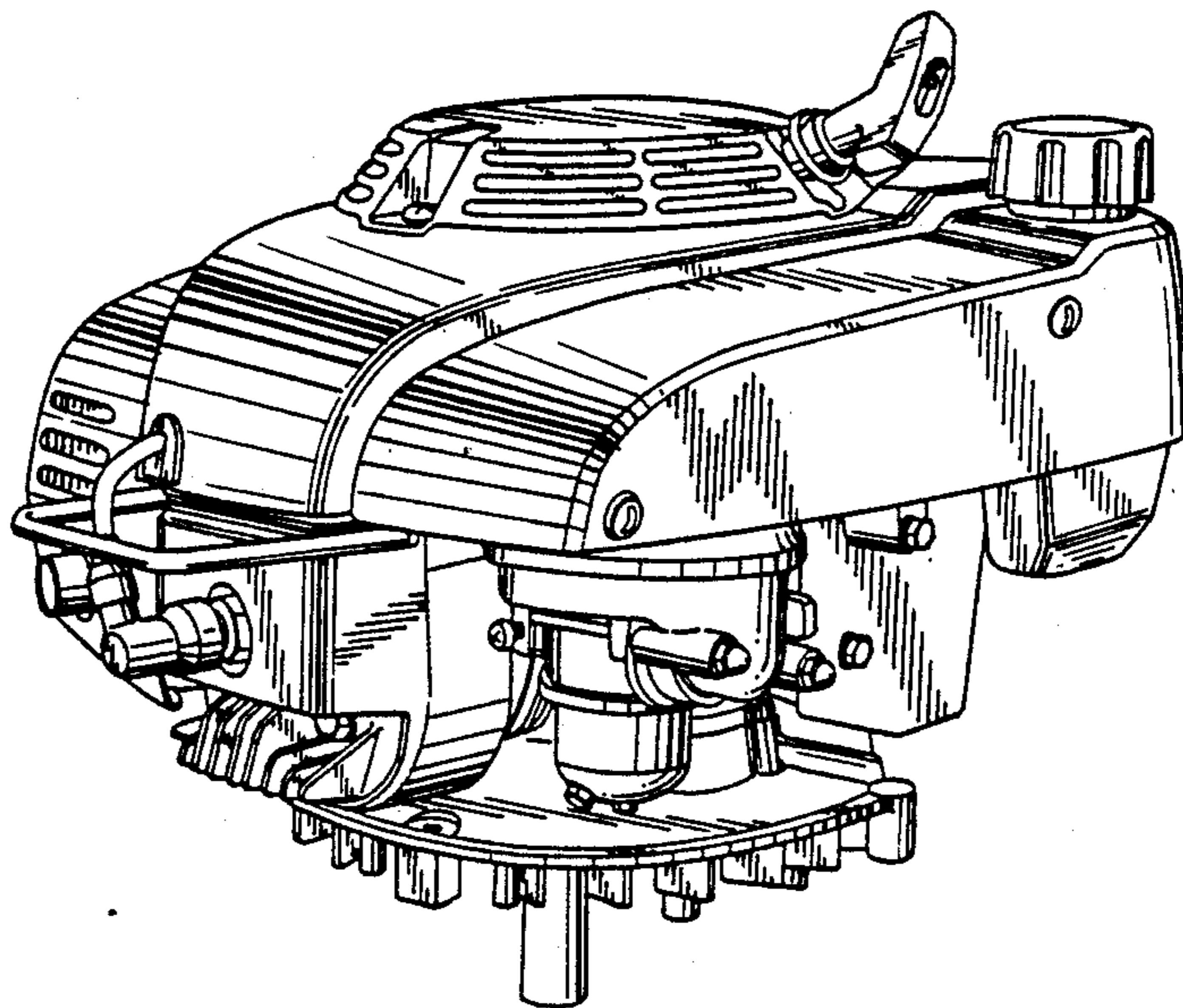

FIG. 1

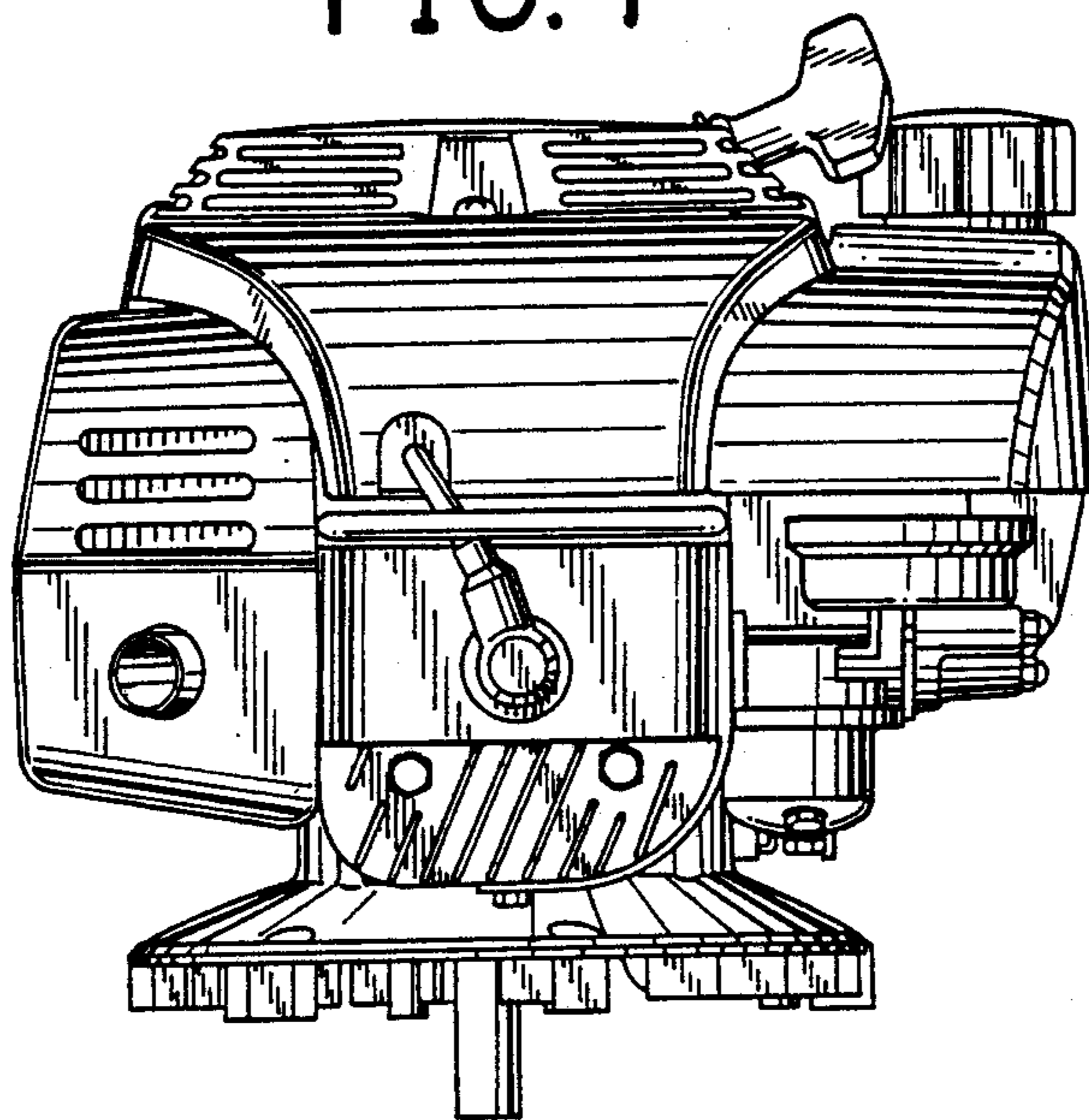

FIG. 2

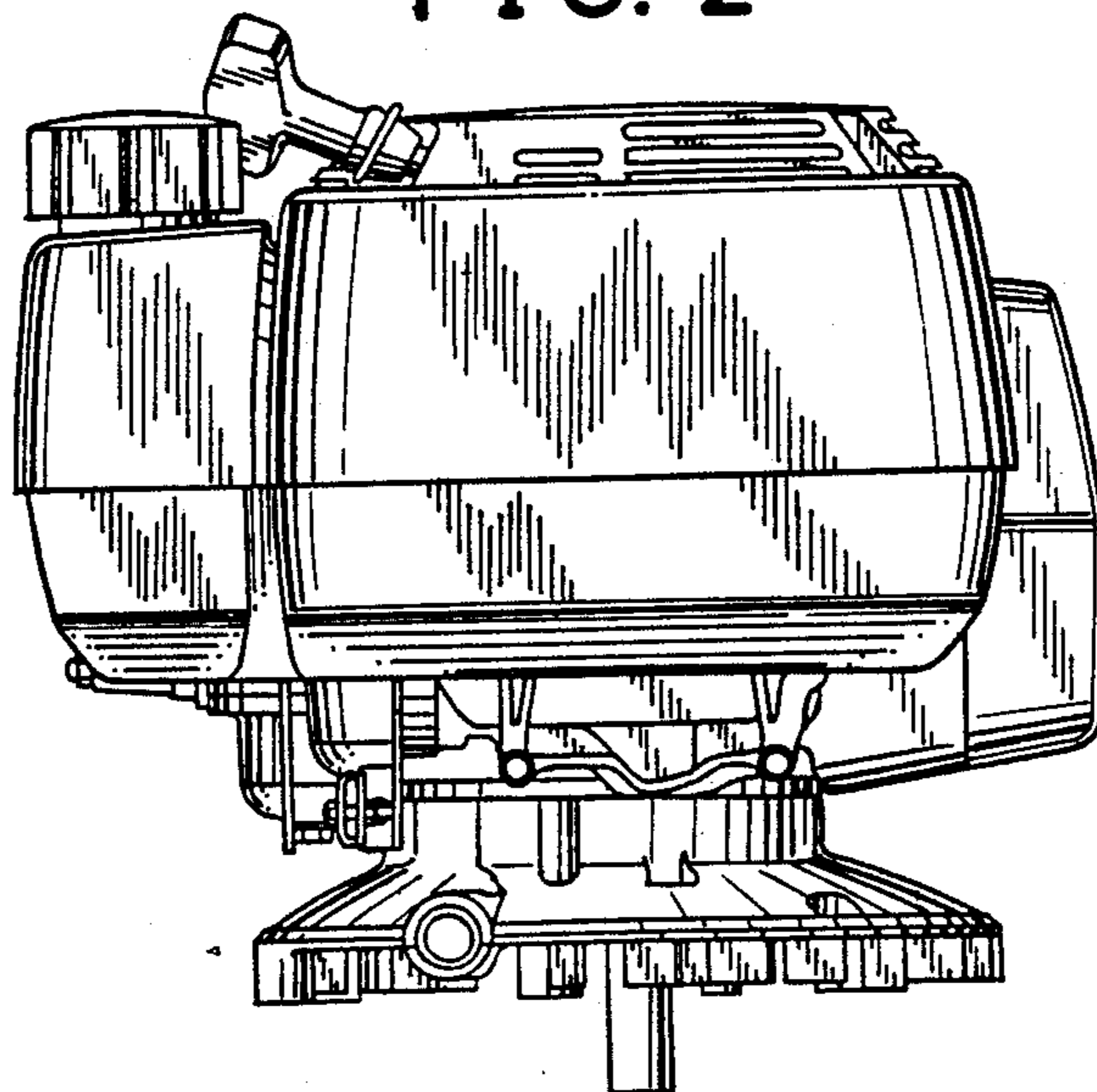

FIG. 3

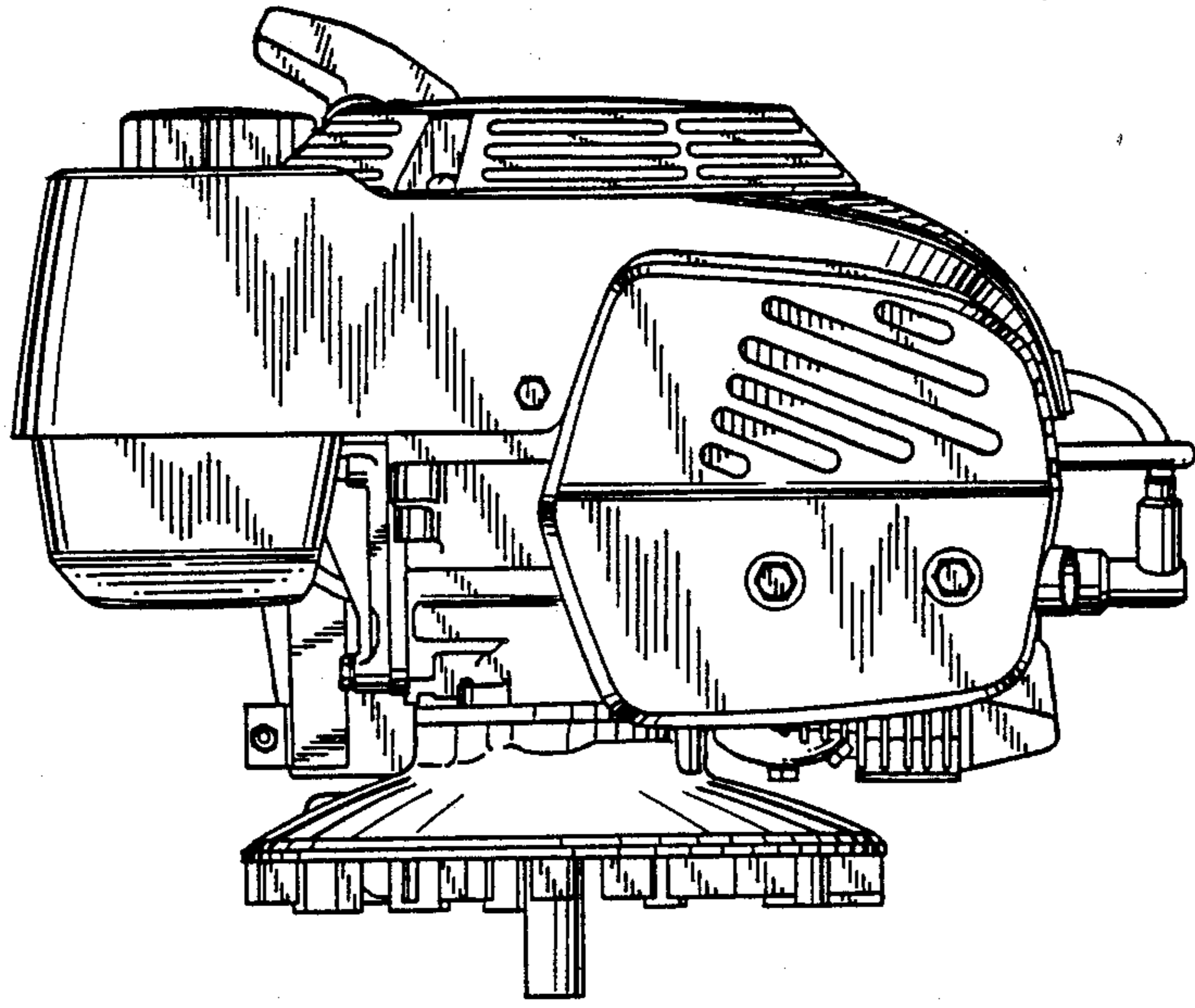

FIG. 4

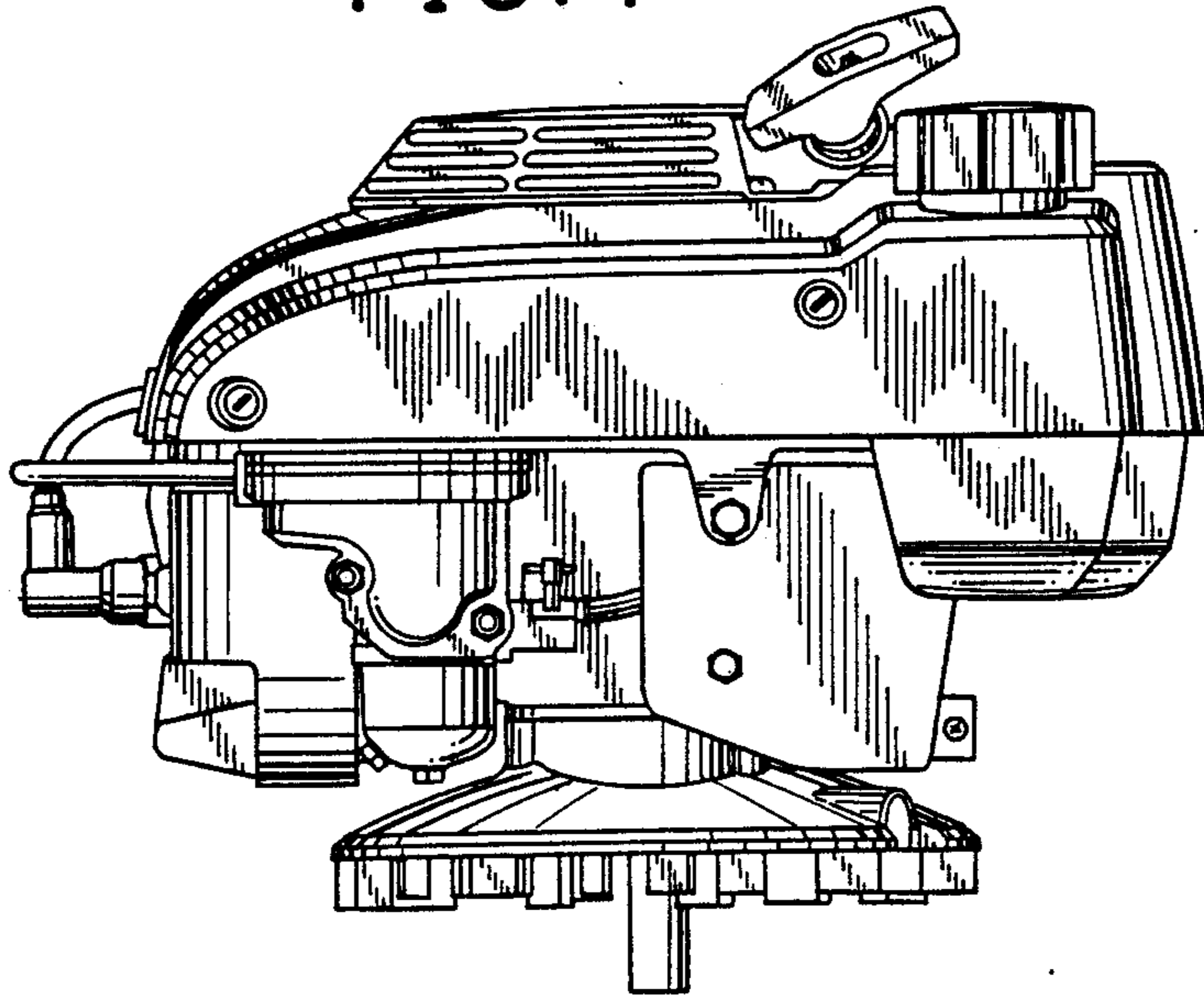

FIG. 5

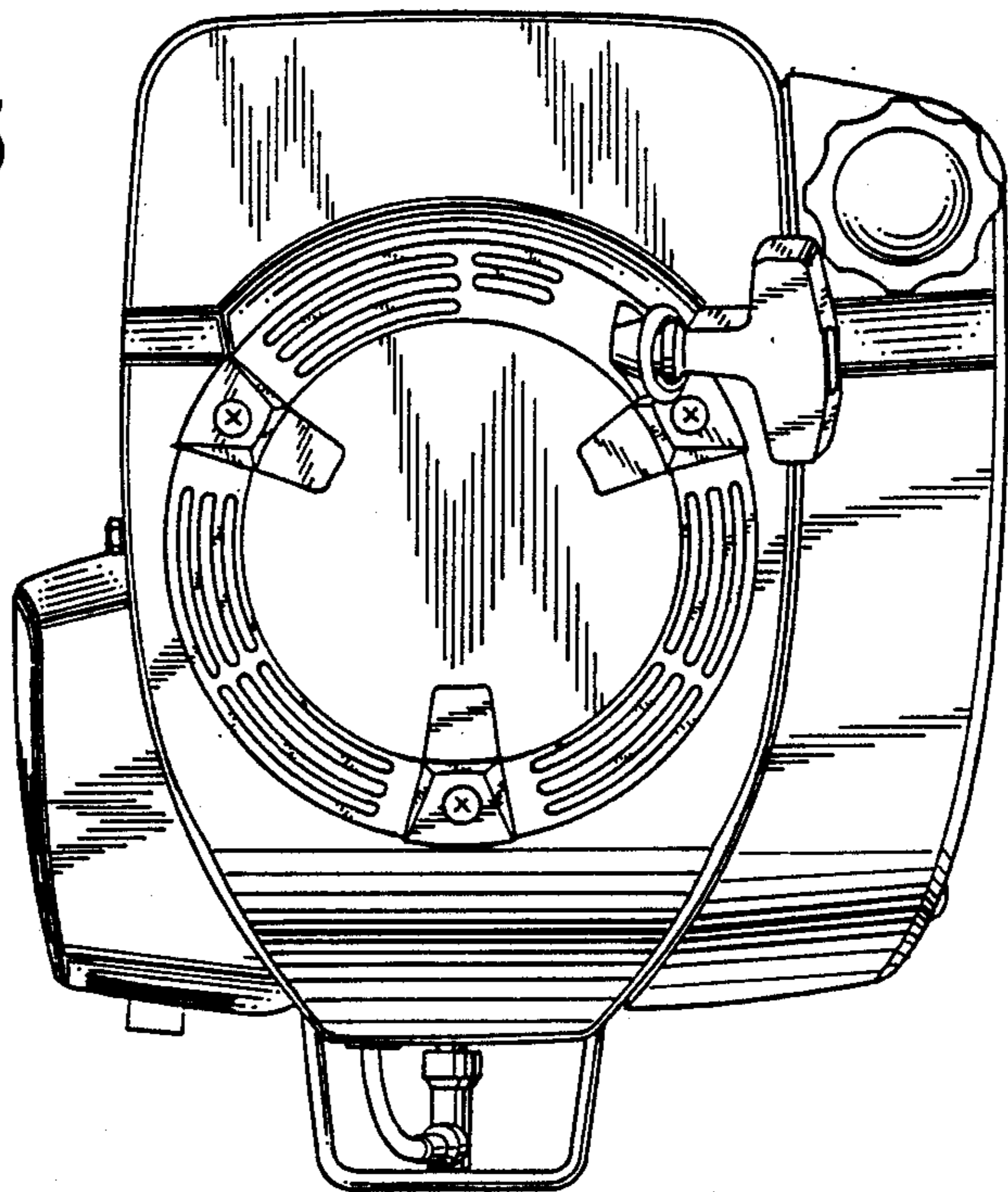

FIG. 6

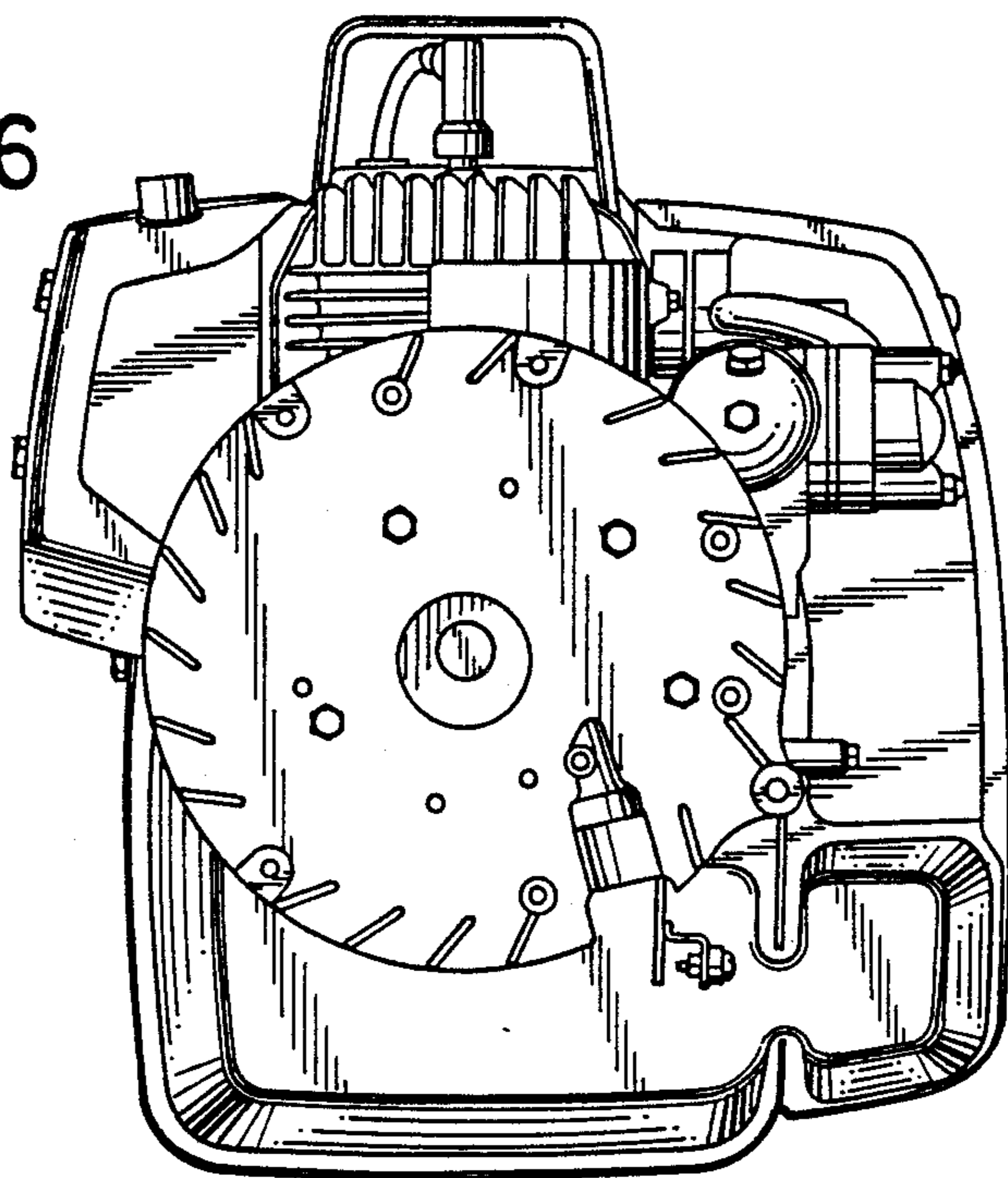

FIG. 7

