

[54] AIR VEHICLE

[75] Inventor: Dale C. Kramer, Port Colborne, Canada

[73] Assignee: Hystar Aerospace Development Corporation, Vancouver, Canada

[**] Term: 14 Years

[21] Appl. No.: 5,522

[22] Filed: Jan. 20, 1987

[30] Foreign Application Priority Data

Oct. 29, 1986 [JP] Japan 61-042961
[52] U.S. Cl. D12/325; D21/87
[58] Field of Search D12/319, 320, 323, 325; D21/82, 84, 85, 86, 87, 90, 91, 108, 150; 446/36, 85, 88, 93, 94, 108, 116, 118, 120, 220, 225, 230, 231, 232; 244/23 C, 24, 26, 29, 34 A, 34 R

[56] References Cited

U.S. PATENT DOCUMENTS

D. 213,731	4/1969	Hsi	D12/323
2,935,275	5/1960	Grayson	D12/325
3,477,168	11/1969	Trodglen	244/23 C
4,461,436	7/1984	Messina	244/23 C
4,685,640	8/1987	Warrington et al.	244/29

Primary Examiner—Charles A. Rademaker
Assistant Examiner—Alicia A. Farrell
Attorney, Agent, or Firm—Rogers, Bereskin & Parr

[57] CLAIM

The ornamental design for an air vehicle, as shown.

DESCRIPTION

FIG. 1 is a top perspective view of an air vehicle showing my new design;
FIG. 2 is a bottom perspective view thereof;
FIG. 3 is a top plan view thereof;
FIG. 4 is a bottom plan view thereof;
FIG. 5 is a side elevational view thereof, the side opposite being substantially a mirror image; and
FIG. 6 is a cross-sectional view thereof taken along line A—A in FIG. 3.

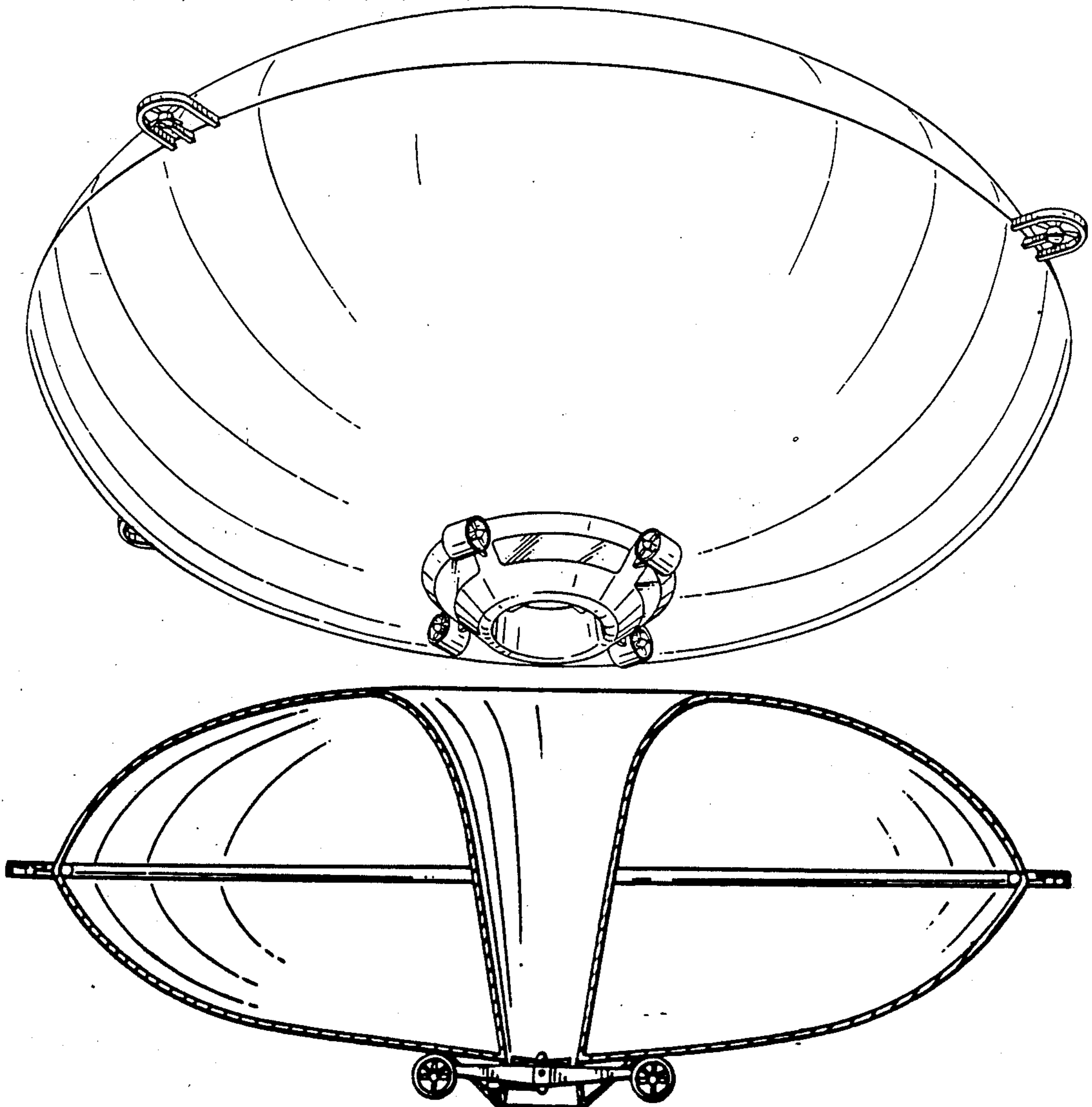

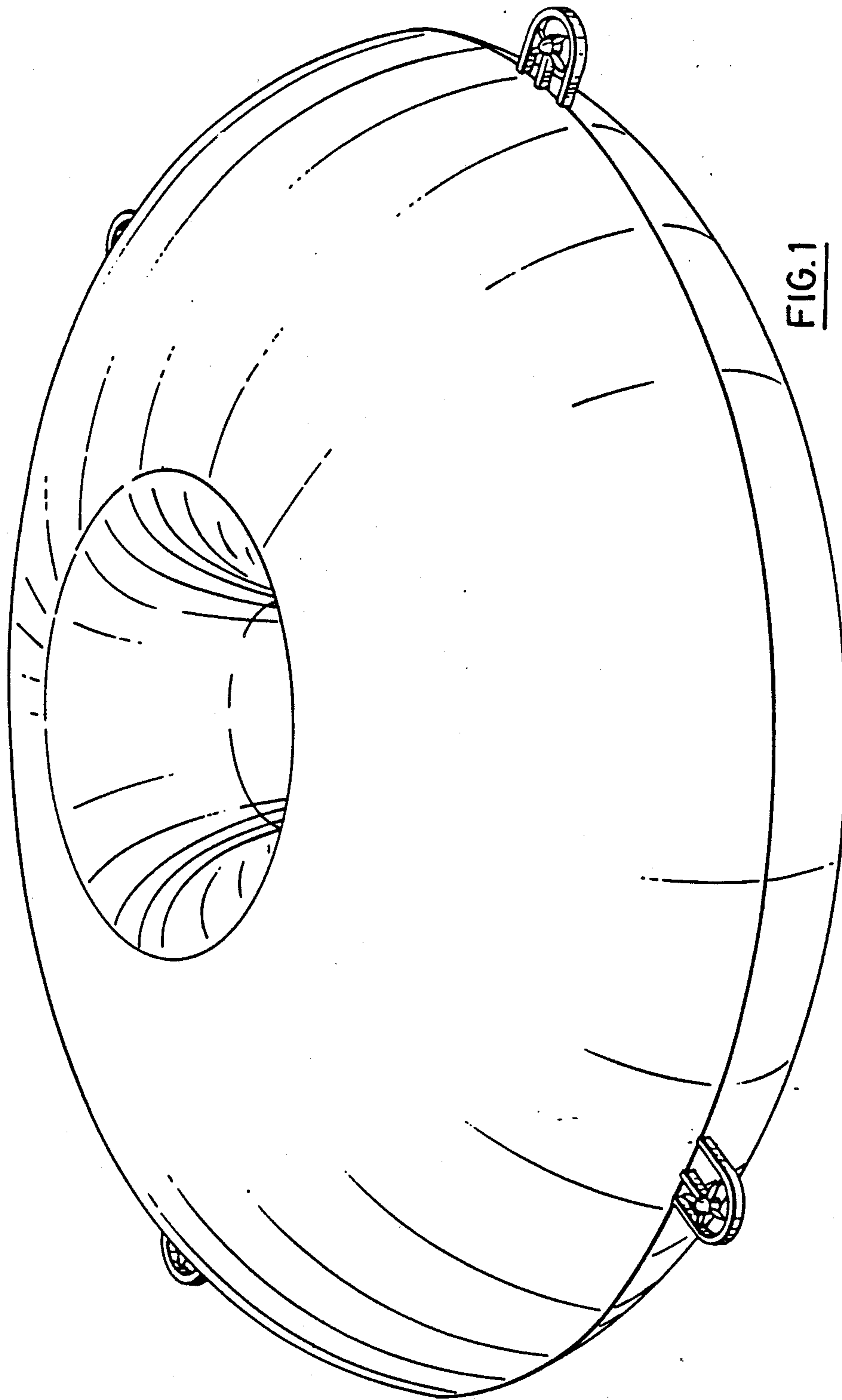

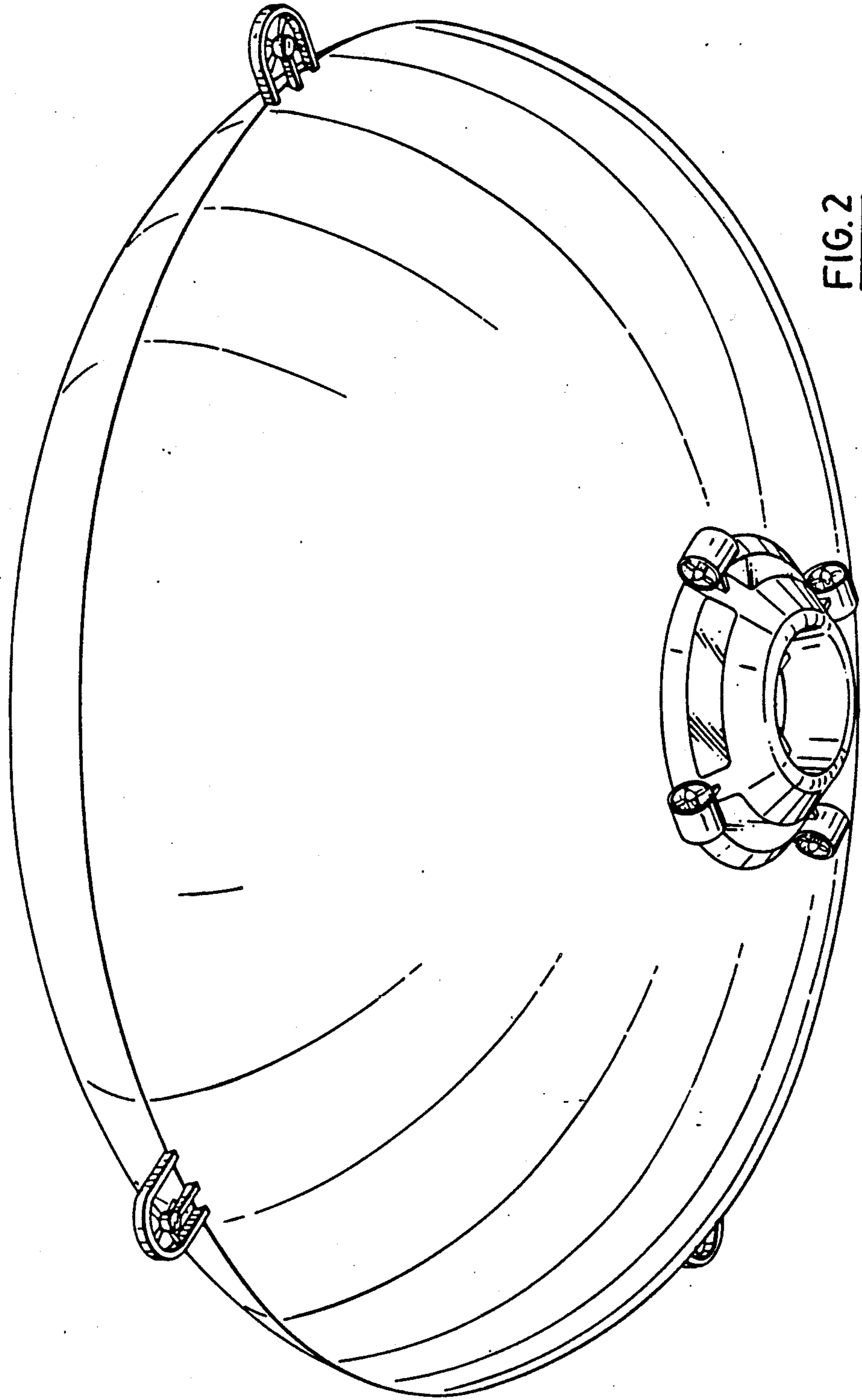

FIG. 2

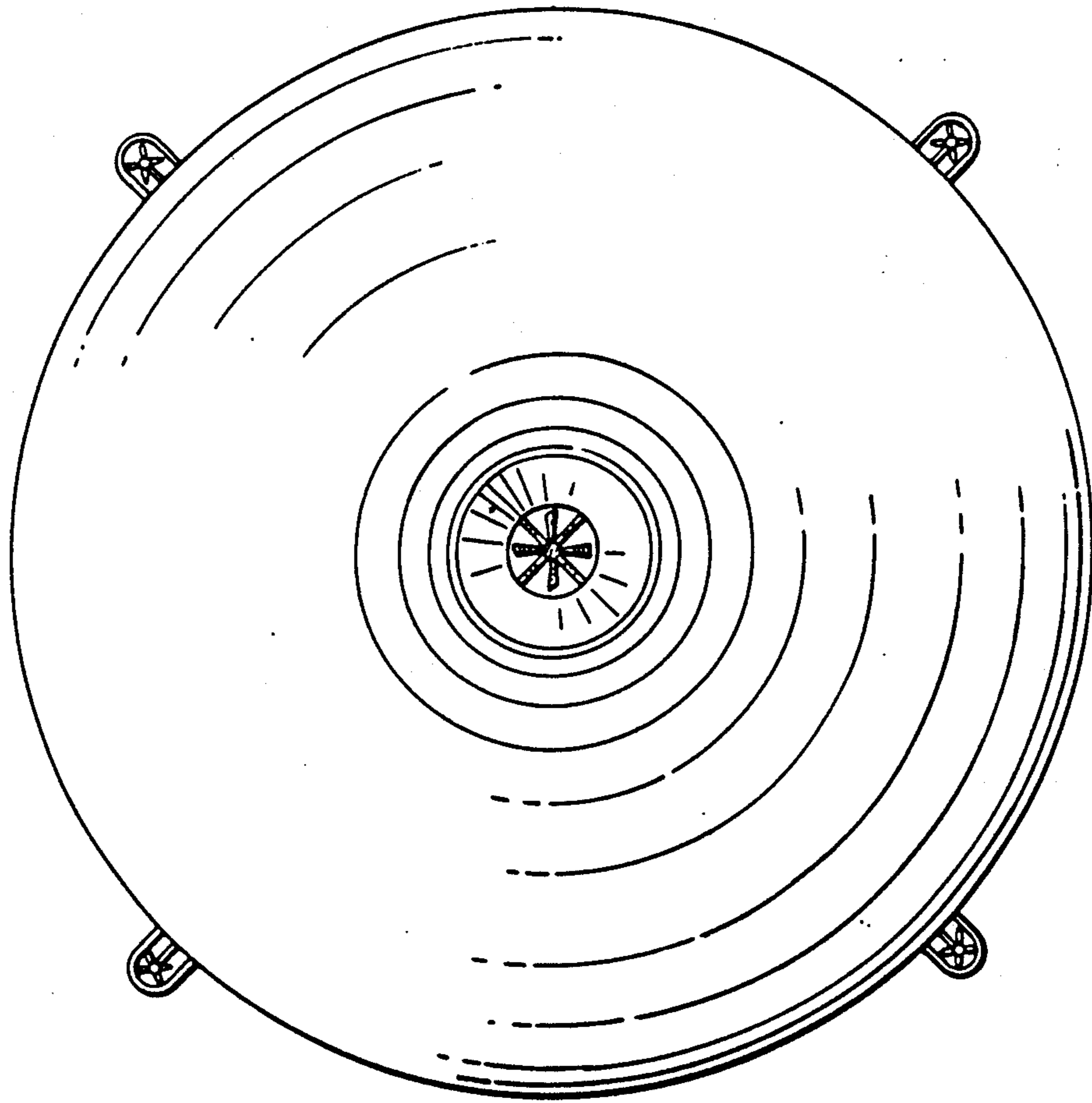

FIG. 3

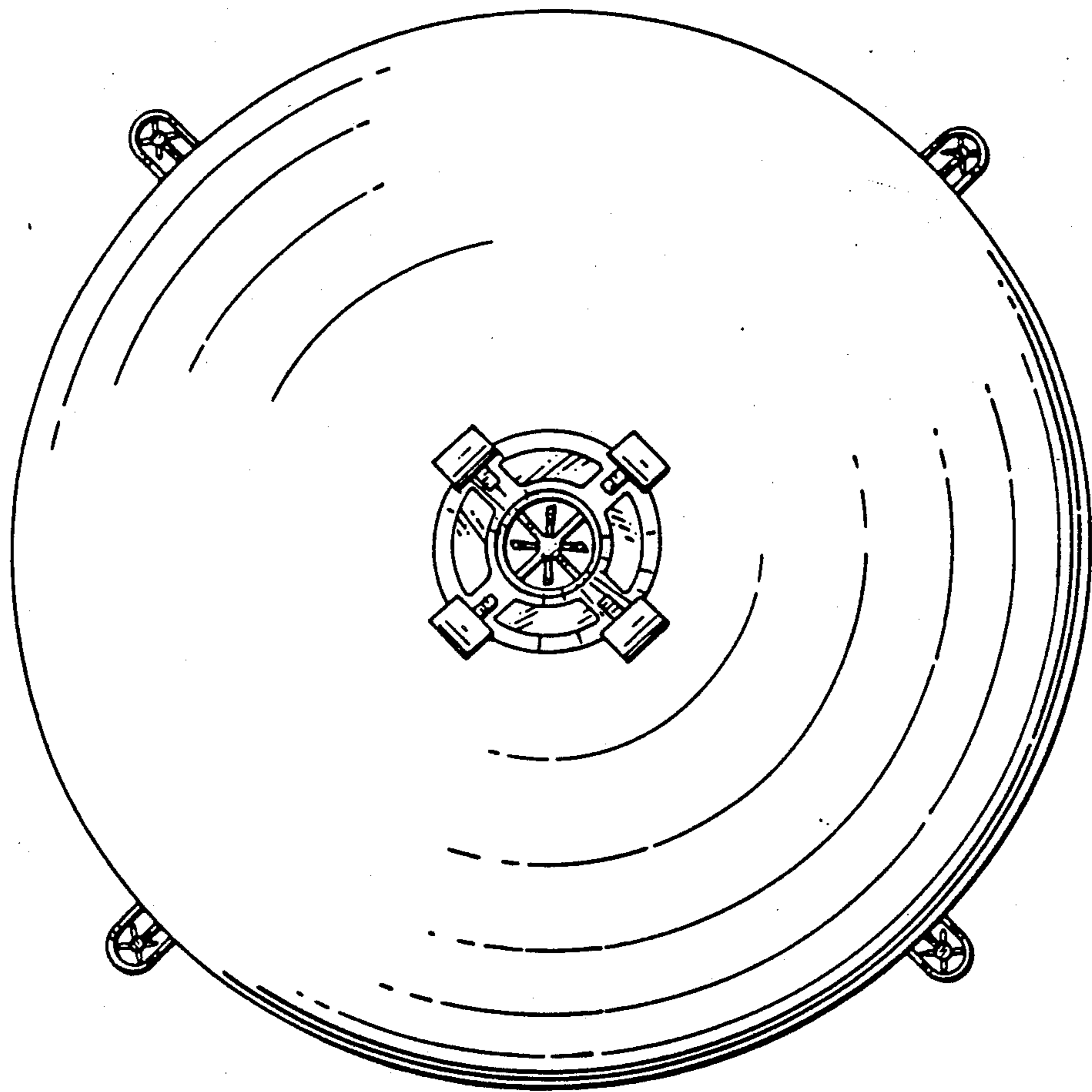

FIG. 4

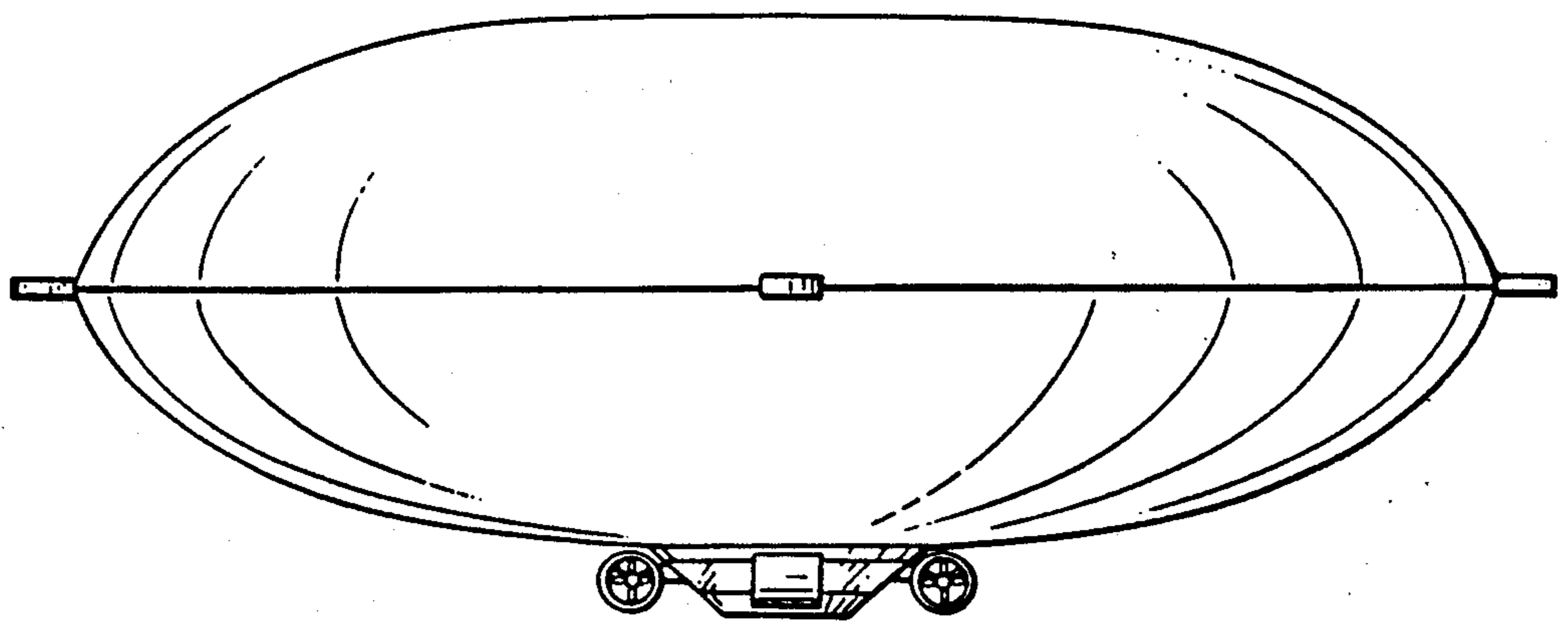

FIG. 5

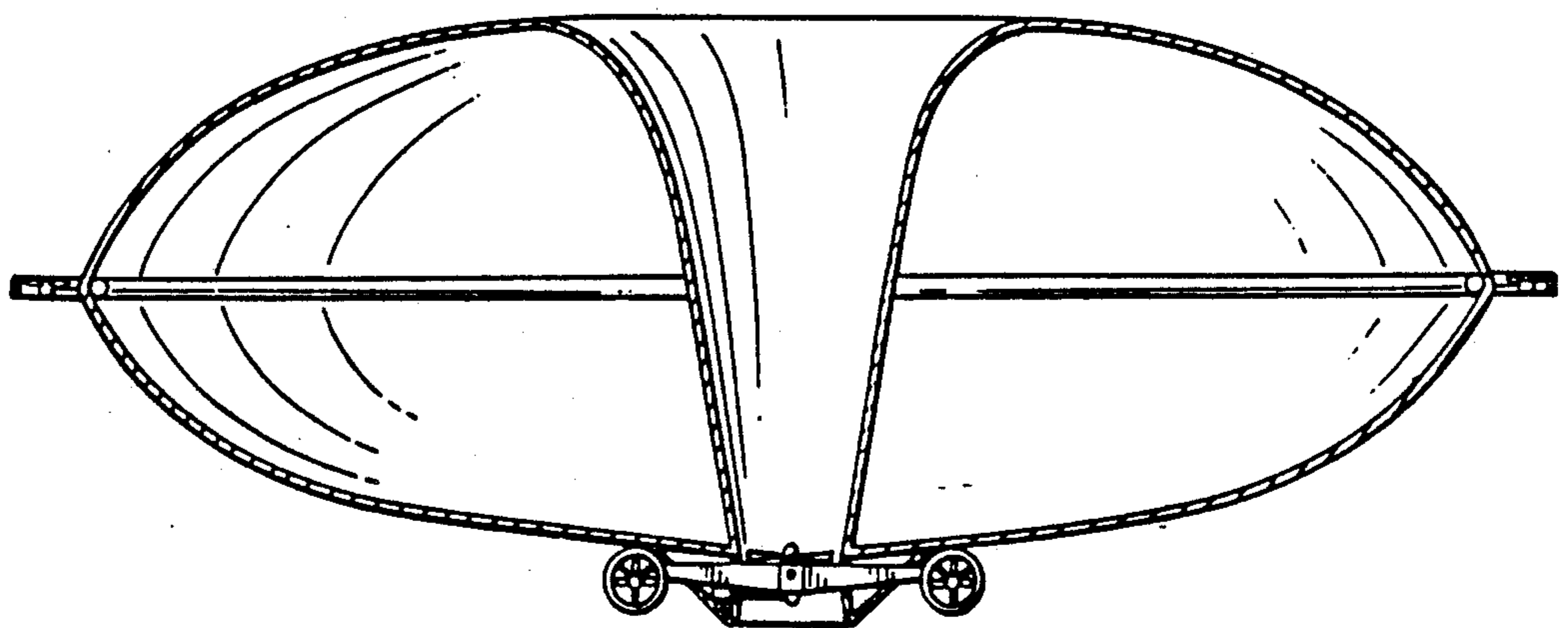

FIG. 6