

[54] **EXTERIOR SHELL OF A VEHICLE HOOD**

[75] **Inventors:** L. David Allendorph; Larry N. Reynard, both of Fort Wayne, Ind.

[73] **Assignee:** Navistar International Transportation Corp., Chicago, Ill.

[*] **Notice:** The portion of the term of this patent subsequent to Mar. 6, 2004 has been disclaimed.

[**] **Term:** 14 Years

[21] **Appl. No.:** 85,927

[22] **Filed:** Aug. 14, 1987

Related U.S. Application Data

[63] Continuation-in-part of Ser. No. 15,183, Feb. 17, 1987.

[52] **U.S. Cl.** D12/173

[58] **Field of Search** D12/173, 96; 180/69.2, 180/89.12, 89.13; 296/183, 190

**References Cited
PUBLICATIONS**

Commercial Carrier Journal, 7/85, p. 174, Hood of Mack Truck, top of page.

Commercial Carrier Journal, 8/85, p. 29, Hood of Ford 9000 Truck, top of page.

Commercial Carrier Journal, 9/85, inside front cover, Hood of Freightliner Truck.

Commercial Carrier Journal, 3/86, p. 162, Hood of International Truck, bottom left side of page.

Commercial Carrier Journal, 4/87, p. 50, Hood of Volvo White Truck, top center of page.

Commercial Carrier Journal, 4/87, p. 165, Nelson Hood, top center of page.

Primary Examiner—James M. Gandy
Attorney, Agent, or Firm—F. David AuBuchon; Dennis K. Sullivan

[57] **CLAIM**

The ornamental design for an exterior shell of a vehicle hood, as shown and described.

DESCRIPTION

FIG. 1 is a left, front perspective view of an exterior shell of a vehicle hood showing our new design, it being understood that the broken lines are for illustrative purposes only and form no part of the claimed design; FIG. 2 is a front elevation view thereof; FIG. 3 is a left side elevation view thereof, the right side being a mirror image of that shown; and FIG. 4 is a top plan view thereof.

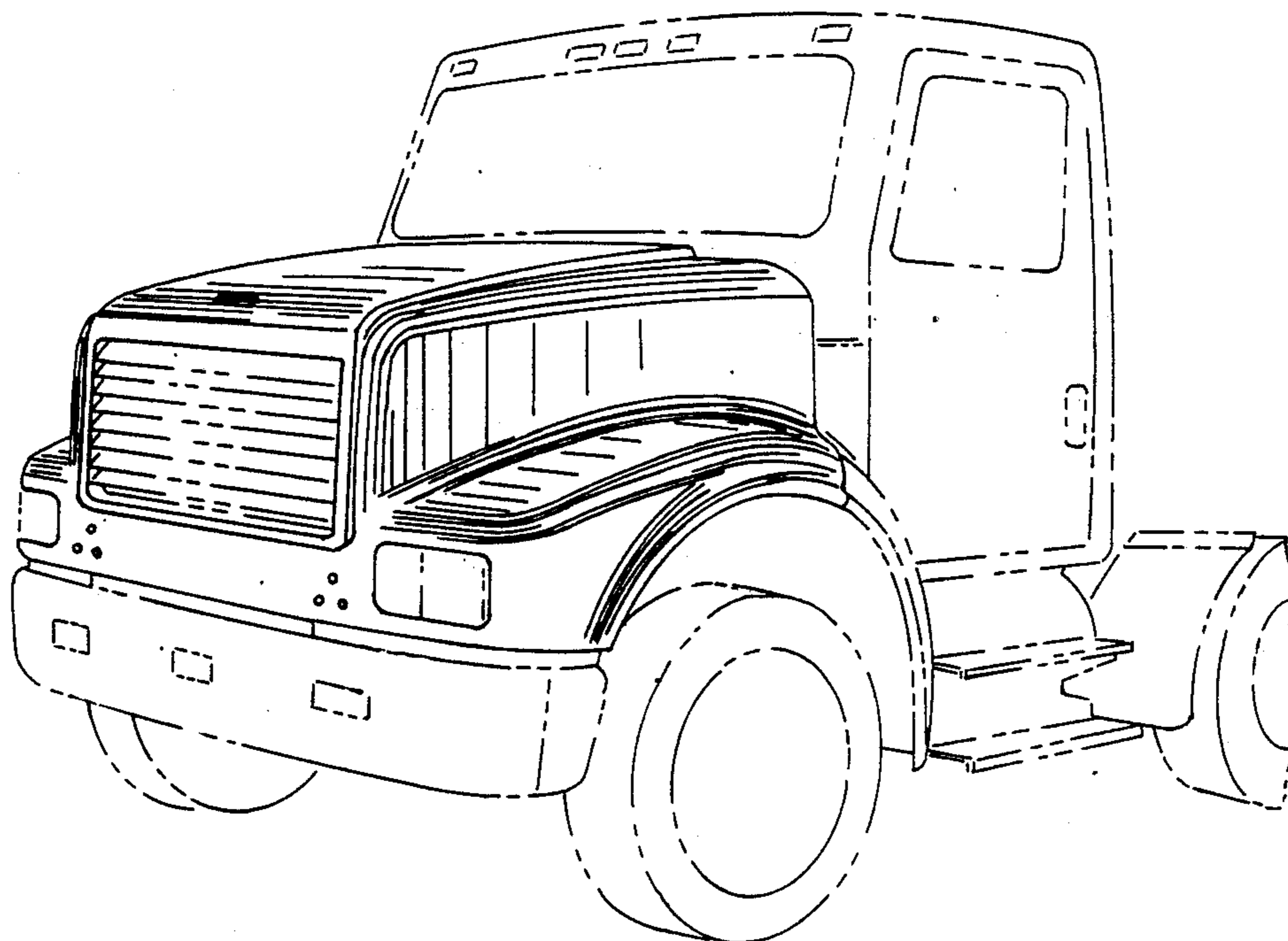

FIG. 1

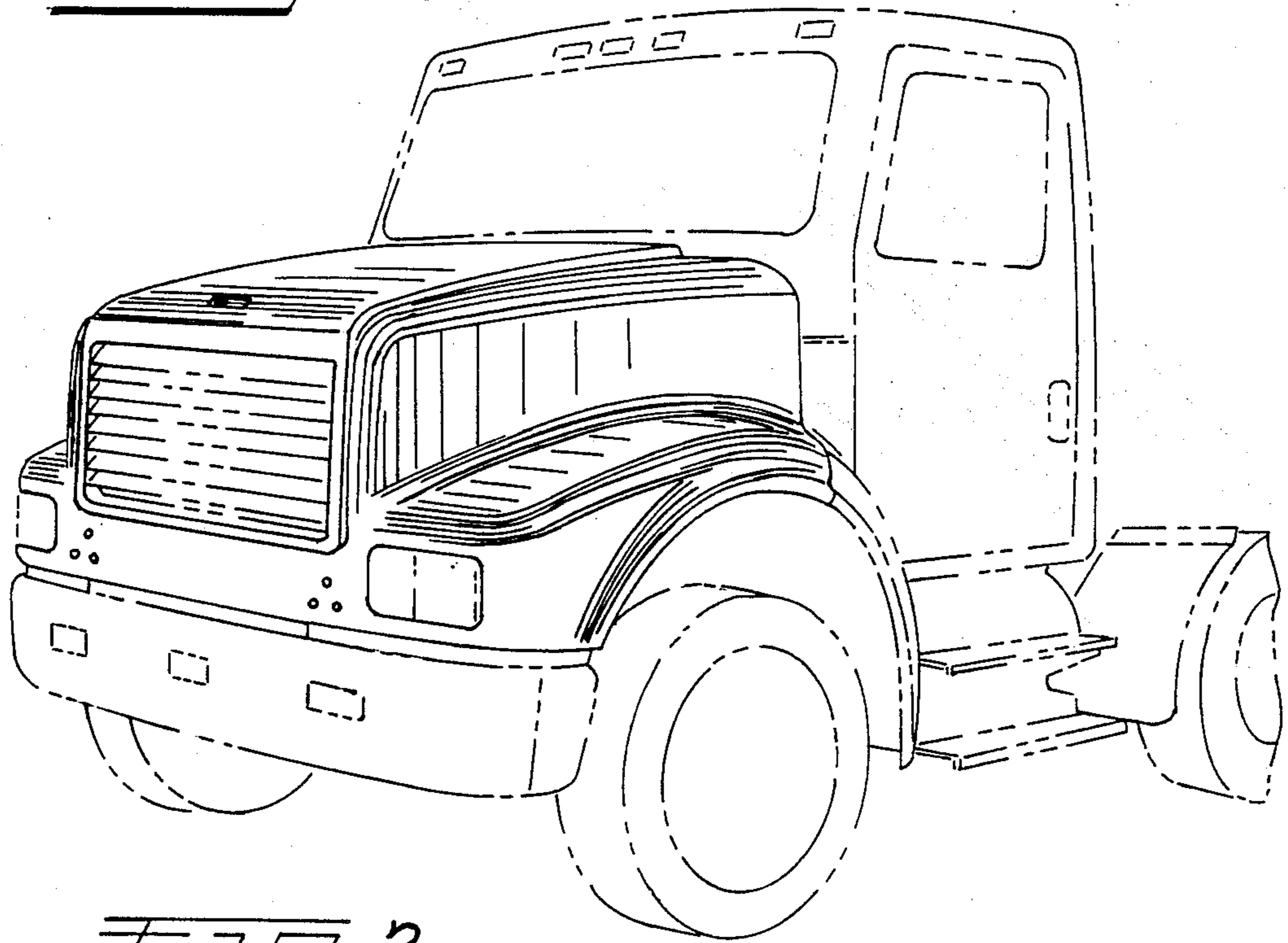

FIG. 2

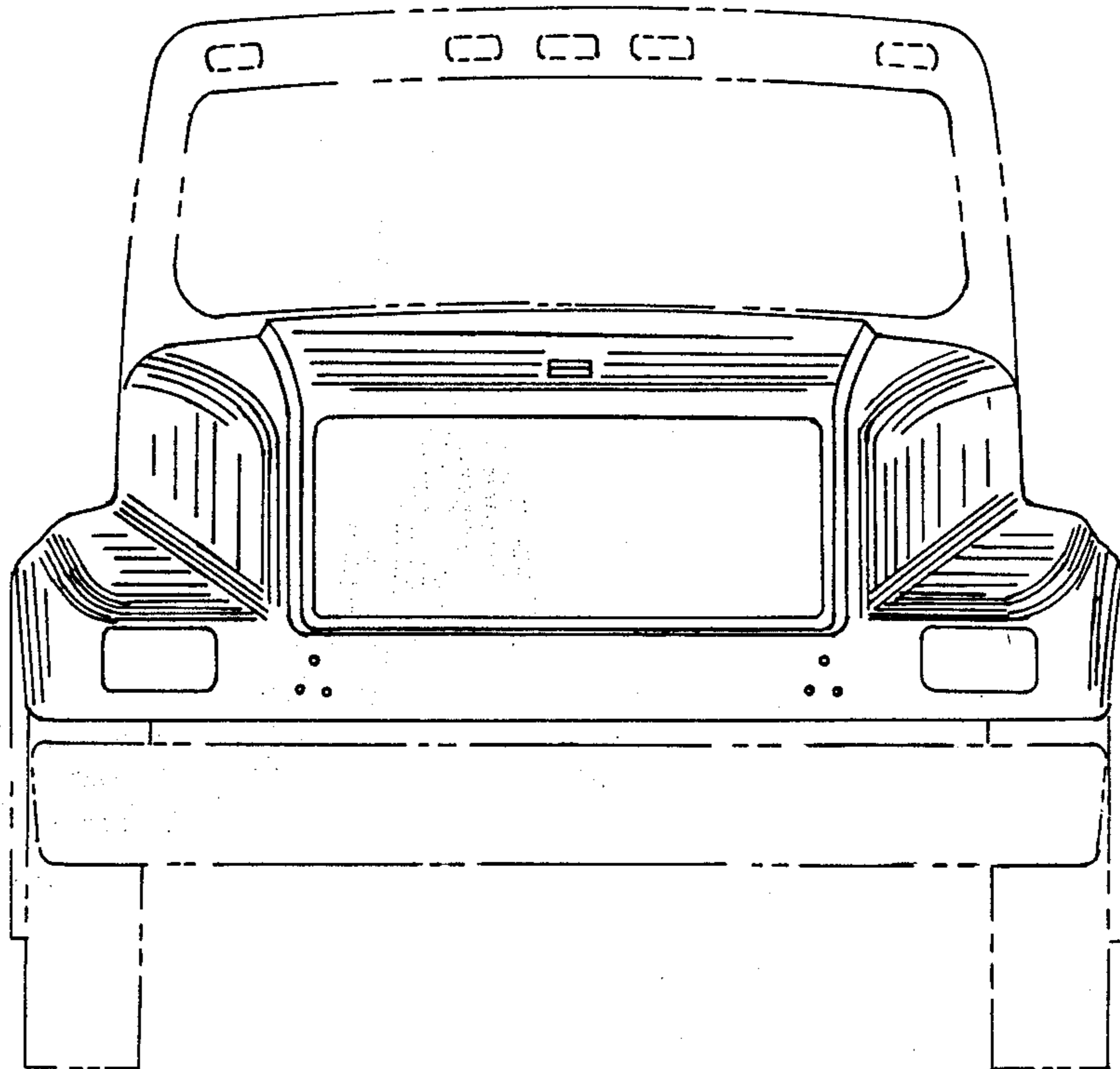

FIG. 3

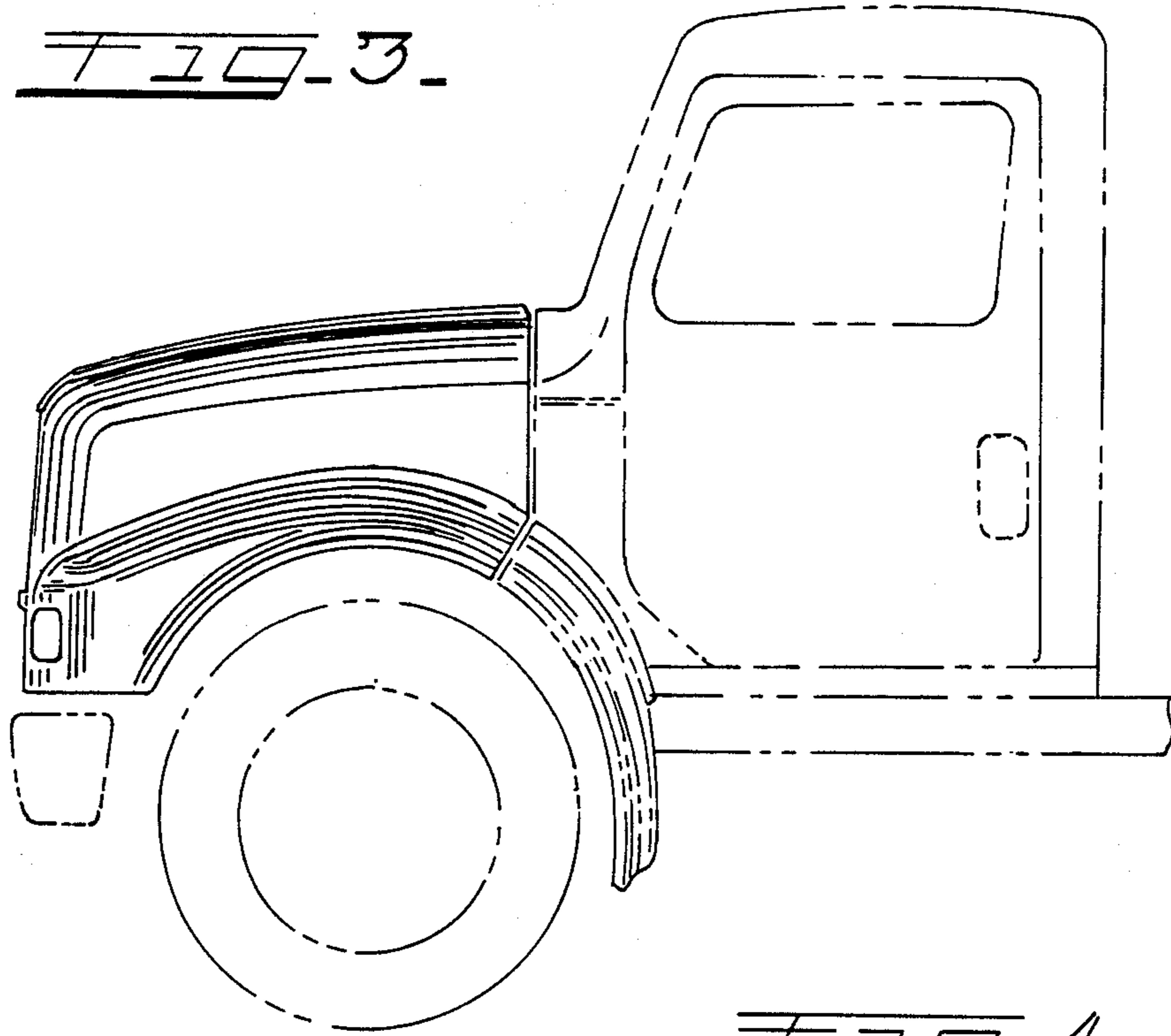

FIG. 4

