

[54] RADIATOR GRILLE FOR AN AUTOMOBILE

[75] Inventors: Akikazu Hayashi, Aichi; Naoto Furukado; Nobuyuki Matsukuma, both of Kariya, all of Japan

[73] Assignee: Toyota Jidosha Kabushiki Kaisha, Toyota, Japan

[**] Term: 14 Years

[21] Appl. No.: 49,241

[22] Filed: May 13, 1987

[52] U.S. Cl. D12/163

[58] Field of Search D12/163; 180/68.6

[56] References Cited

U.S. PATENT DOCUMENTS

- D. 274,234 6/1984 Koyanagi D12/163
- D. 285,299 8/1986 Wardle et al. D12/163
- D. 286,276 10/1986 Vahlenbreder D12/163
- D. 291,553 8/1987 Kawaguchi D12/163

FOREIGN PATENT DOCUMENTS

- D. 580162 7/1982 Japan .
- D. 617029 1/1984 Japan .

OTHER PUBLICATIONS

Road & Track, 1/86, p. 46, front grille of Toyota Celica GT Liftback, lower left side of page.

Primary Examiner—James M. Gandy
Attorney, Agent, or Firm—Cushman, Darby & Cushman

[57] CLAIM

The ornamental design for a radiator grille for an automobile, as shown.

DESCRIPTION

FIG. 1 is a front perspective view of a radiator grille for an automobile showing our new design;
 FIG. 2 is a front elevational view of FIG. 1;
 FIG. 3 is a rear elevational view of FIG. 1;
 FIG. 4 is a top plan view of FIG. 1;
 FIG. 5 is a bottom plan view of FIG. 1;
 FIG. 6 is a left side elevational view of FIG. 1;
 FIG. 7 is a right side elevational view of FIG. 1; and
 FIG. 8 is a cross sectional view taken along line VIII-VIII of FIG. 2.

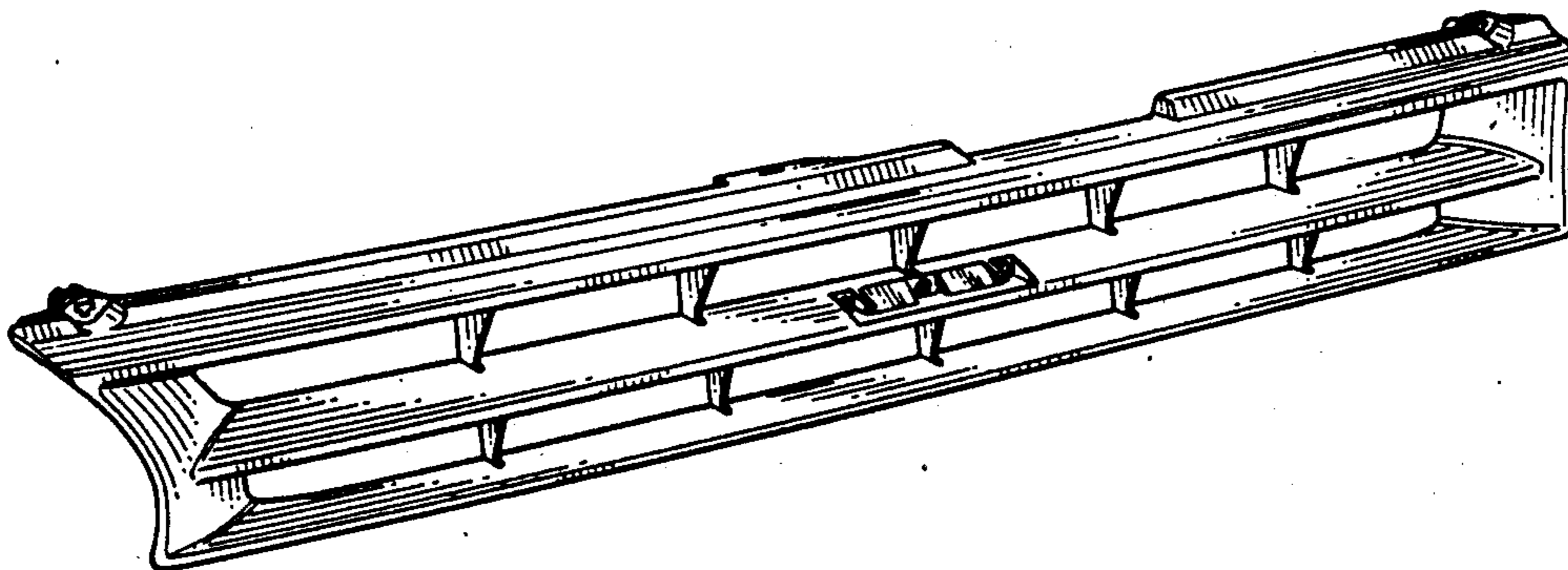

Fig. 1

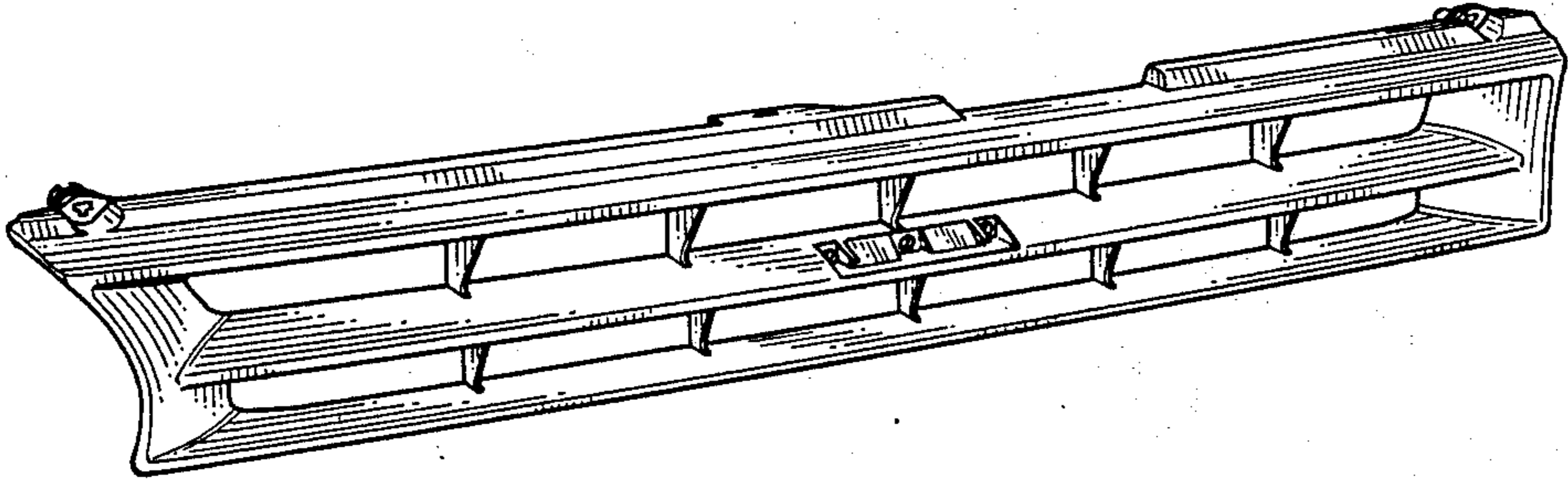

Fig. 2

VIII

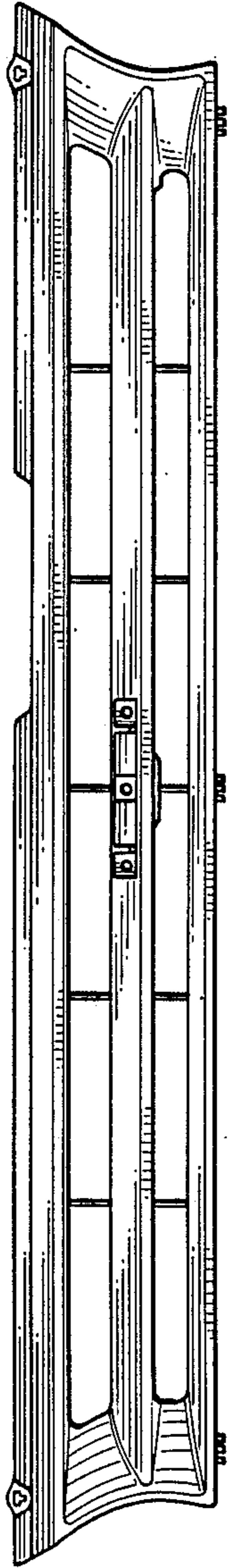

Fig. 3

VIII

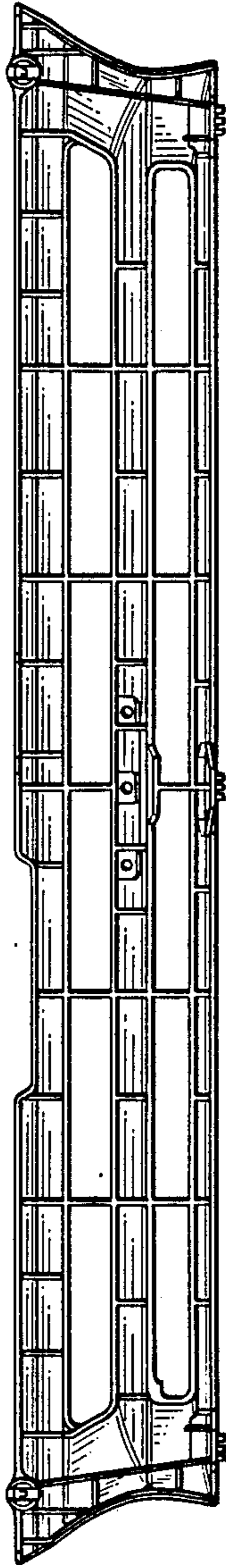

Fig. 4

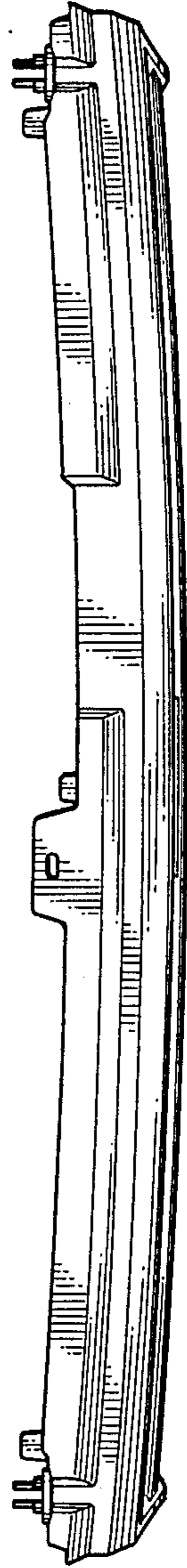

Fig. 5

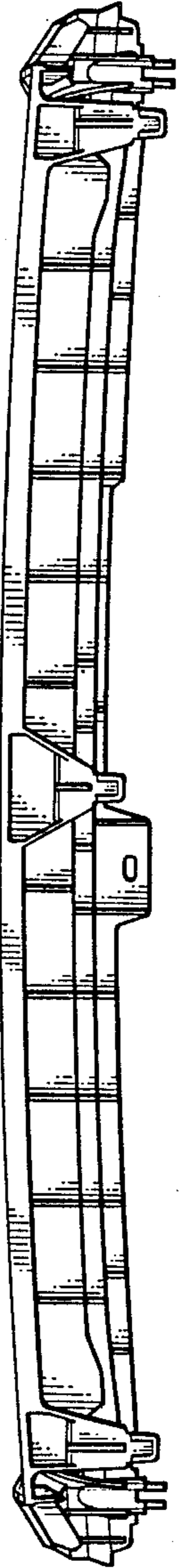

Fig. 6

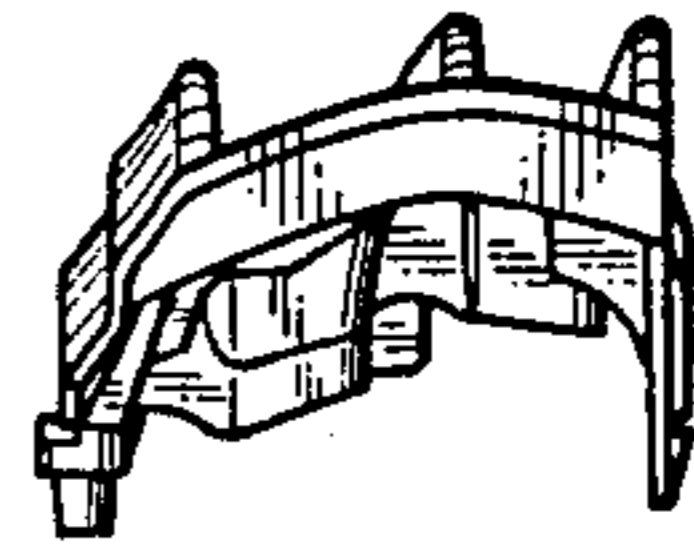

Fig. 7

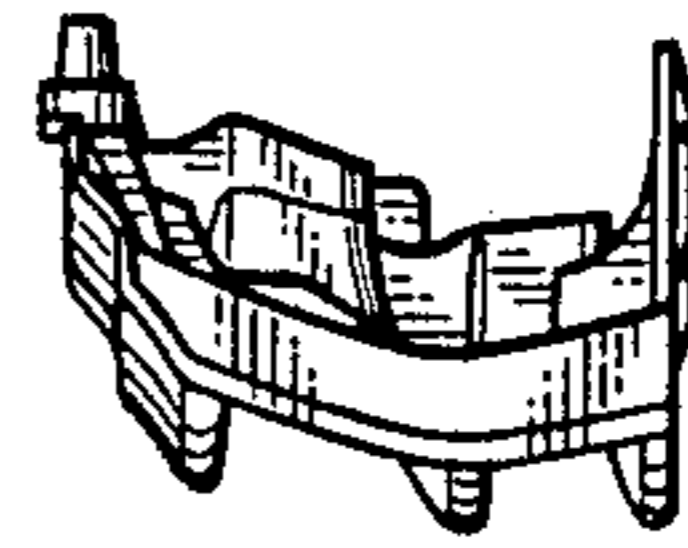

Fig. 8

